

Operating Manual
Axioscope 5/7/Vario



Upright Microscope for Routine and Entry-level Research

We make it visible.

Knowledge of this manual is essential for the operation of the instrument. Please familiarize yourself with the contents of this manual and pay special attention to instructions concerning safe operation of the instrument.

The specifications are subject to change; the manual is not covered by an update service.

© Unless expressly authorized, dissemination and duplication of this document as well as commercial exploitation and communication of its contents are not permitted. Persons in contravention of this copyright are liable to pay compensation for damages.

All rights reserved, including rights created by patent grant or registration of a utility model.

All names of companies and products mentioned in this manual may be trademarks or registered trademarks. Third party products are cited for information purposes only and this does not represent approval or recommendation of these products.

Carl Zeiss Microscopy GmbH assumes no liability for the performance or use of such products.



authorized dealer:
Pulch + Lorenz microscopy
Am Untergrün 23, D-79232 March
tel: 07665 9272-0
fax: 07665 9272-20
mail: kontakt@pulchlorenz.de
web: pulchlorenz.de

Published by

Carl Zeiss Microscopy GmbH
Carl-Zeiss-Promenade 10
07745 Jena, Germany

microscopy@zeiss.com
www.zeiss.com/microscopy



Carl Zeiss Suzhou Co., Ltd.
Modern Industrial Square 3-B, No.333
XingPu Road SIP
215126 Suzhou, China

Order No.: 430035-7344-001

Issue date: Version 3 – 15 March 2018

CONTENTS

	Page
1	INTRODUCTION 9
1.1	Notes on instrument safety 9
1.2	Warning labels on the microscopes..... 13
1.3	Notes on the warranty..... 16
2	DESCRIPTION OF THE INSTRUMENT 17
2.1	Intended use..... 17
2.2	Technical data..... 18
2.3	Interface diagram 20
2.4	Controls and functional elements on the microscope..... 21
2.4.1	Stand models 21
2.4.2	Axioscope 5 stands, Bio-TL 22
2.4.3	Axioscope 5 stand, Bio-TL/RL 24
2.4.4	Axioscope 5 stand, Pol-TL/RL 26
2.4.5	Axioscope 5 stand, Mat-TL/RL 28
2.4.6	Axioscope 7 stand, Mat-TL/RL mot. 30
2.4.7	Axioscope 5 Vario material stand 32
2.4.8	Functions of stands keys and display elements..... 34
2.5	Controls and functional elements on microscope components 36
2.5.1	Binocular photo tube 30°/23 (100:0/0:100)..... 36
2.5.2	Binocular ergo tube/ergo photo tube 20°/23 and ergo photo tube 15°/23, each with continuous vertical adjustment 37
2.5.3	Nosepiece with objectives..... 38
2.5.4	Mechanical stage 75x50 38
2.5.5	Low-power system for 2.5x/4x objectives mounted on the condenser carrier 39
2.5.6	0.9/1.25 BF condenser and 0.9 Pol condenser 39
2.5.7	14x40 mm stop sliders for aperture and field diaphragms..... 40
2.5.8	Reflector turrets with 4 or 6 coded positions 41
2.5.9	Reflector slider with 2 coded positions 41
3	START-UP 42
3.1	Mounting standard components 42
3.1.1	Unpacking and setting up microscope stand 42
3.1.2	Mounting the Axioscope 5 Vario material upper stand part on the stand column 43
3.1.3	Mounting the binocular tube/photo tube 44
3.1.4	Inserting eyepieces or auxiliary microscope or pinhole diaphragm 44
3.1.5	Screwing in objectives 46
3.1.6	Inserting and removing push-and-click (P&C) reflector modules into the reflector insert... 47
3.1.7	Mounting the reflector insert..... 48
3.1.8	Mounting the mechanical stage..... 48

3.1.9	Mechanical stages with friction adjustment.....	52
3.1.10	Attaching the Pol rotary stage	53
3.1.11	Mounting/removing the 80x60 motorized mechanical stage on the Axioscope 7 motorized material stand	56
3.1.12	Mounting the condenser carrier	57
3.1.13	Mounting the condenser.....	57
3.1.14	Mounting the darkfield condenser.....	58
3.1.15	Mounting the stage carrier.....	59
3.1.16	Changing the 12 V, 50 W halogen lamp of the HAL 50 halogen illuminator	60
3.1.17	Mounting the illuminator TL LED10 CRI90/RL LED10 CRI90	61
3.1.18	Mounting the Axioscope base plate on the stand.....	62
3.1.19	Mounting and adjusting the HAL 100 halogen illuminator.....	63
3.1.20	Inserting the adjustment tool of HBO 100 into the stand Bio-TL/RL	66
3.1.21	Mounting and adjusting the HBO 100 illuminator	66
3.1.22	Mounting the Colibri 3 illumination system and changing the LED modules.....	69
3.1.23	Mounting the external illumination fixture HXP 120.....	71
3.2	Mounting optional components	72
3.2.1	Mounting the intermediate plate for Analyzer Slider	72
3.2.2	Mounting the tube lens turret	73
3.2.3	Mounting the magnification changer.....	73
3.2.4	Changing the filters in the reflector module FL P&C	74
3.2.5	Changing the color splitter in the reflector module FL P&C.....	75
3.2.6	Mounting the polarizer D or the filter holder.....	76
3.2.7	Mounting and centering the low-power system for 2.5x/4x objectives	77
3.2.8	Inserting the modulator disk in the 0.9/1.25 BF condenser	78
3.2.9	Changing the PlasDIC diaphragm	79
3.2.10	Changing the PhC-DIC-PlasDIC diaphragm on the 0.9 BF DF PhC DIC achromatic- aplanatic condenser	79
3.2.11	Changing the filter in the filter wheel transmitted light	80
3.3	Connecting to the power supply and switching the microscope on/off.....	81
3.3.1	Microscope stand.....	81
3.3.2	Connecting the HAL 100 halogen illuminator for transmitted light	82
3.3.3	Connecting the HAL 100 halogen illuminator for reflected light	82
3.3.4	Switching the illumination on/off.....	83
3.4	Using the Light Manager function.....	84
3.5	Default factory settings of the microscope	84
4	OPERATION	85
4.1	Default setting of the microscope.....	85
4.1.1	Setting the inter-pupillary distance on the binocular tube	85
4.1.2	Setting the viewing height	85
4.1.3	Adjusting for ametropia (user's visual impairment) when using eyepiece reticles	86
4.2	Illumination and contrast methods in transmitted light microscopy	87
4.2.1	Setting up transmitted light brightfield microscopy using the KÖHLER method	87

4.2.2	Setting up transmitted light darkfield microscopy using the KÖHLER method	90
4.2.3	Setting up transmitted light phase contrast microscopy	93
4.2.4	Setting up transmitted light differential interference contrast (DIC) microscopy	95
4.2.5	Setting up transmitted light PlasDIC contrast microscopy	97
4.2.6	Setting transmitted light polarization	98
4.2.7	Setting transmitted light polarization for conoscopic observation - determining the optical character of crystals	106
4.3	Illumination and contrast methods in reflected light microscopy	112
4.3.1	Setting up reflected light brightfield microscopy using the KÖHLER method	112
4.3.2	Setting the reflected light darkfield	115
4.3.3	Setting reflected light DIC and reflected light C-DIC	116
4.3.4	Setting reflected light TIC	117
4.3.5	Setting reflected light polarization – proof of birefractance and reflection Pleochroism ...	120
4.3.6	Setting up reflected light fluorescence	122
5	CARE, FUSE REPLACEMENT AND SERVICE	125
5.1	Instrument care	125
5.2	Instrument maintenance	126
5.2.1	Checking the instrument	126
5.2.2	Replacing the fuses in the stand	126
5.2.3	Replacing the fuses in the 12 VDC 100 W power supply unit	127
5.3	Troubleshooting	128
5.3.1	Microscope	128
5.4	Maintenance and repair work	131
6	ANNEX	132
6.1	List of abbreviations	132
6.2	Index	134
6.3	Industrial property rights	138
6.4	System overview	138

LIST OF ILLUSTRATIONS

Fig. 1-1	Warning labels on microscopes with LED light source for transmitted light.....	13
Fig. 1-2	Warning labels on microscopes with HAL 100 for transmitted light and HBO 100 for reflected light.....	14
Fig. 1-3	Warning label on microscopes with LED light source for reflected light	14
Fig. 1-4	Warning label on microscopes with Colibri 3 light source for reflected light	15
Fig. 1-5	Warning label on Axioscope 7 stand using the motorized 80x60 mechanical stage 80x60 ...	15
Fig. 2-1	Interface diagram (example: Axioscope 5 stand, Bio-TL/RL)	20
Fig. 2-2	Controls and functional elements of the Axioscope 5 stands, Bio-TL	23
Fig. 2-3	Controls and functional elements of the Axioscope 5 stand, Bio-TL/RL	25
Fig. 2-4	Controls and functional elements of the Axioscope 5 stand, Pol-TL/RL	27
Fig. 2-5	Controls and functional elements of the Axioscope 5 stand, Mat-TL/RL.....	29
Fig. 2-6	Controls and functional elements of the Axioscope 7 stand, Mat-TL/RL mot.....	31
Fig. 2-7	Controls and functional elements of the Axioscope 5 Vario material stand	33
Fig. 2-8	Binocular photo tube.....	36
Fig. 2-9	Binocular ergo photo tube 20°/23 with vertical adjustment	37
Fig. 2-10	Binocular ergo photo tube 15°/23, telescopic with vertical adjustment.....	37
Fig. 2-11	Nosepiece with DIN slot for compensators	38
Fig. 2-12	Mechanical stage with specimen holder.....	38
Fig. 2-13	Low-power system mounted on the condenser carrier.....	39
Fig. 2-14	0.9/1.25 BF condenser with modulator disk	39
Fig. 2-15	14x40 mm stop slider.....	40
Fig. 2-16	Reflector turret with 6 coded positions	41
Fig. 2-17	Reflector slider 2 coded positions.....	41
Fig. 3-1	Setting up the microscope	42
Fig. 3-2	Mounting the Vario upper stand part on the stand column.....	43
Fig. 3-3	Attaching the binocular tube	44
Fig. 3-4	Inserting eyepieces	44
Fig. 3-5	Inserting the E-PL 10x/23 GW foc. Pol eyepieces into the binocular photo tube with upright image	45
Fig. 3-6	Inserting the eyepiece reticle.....	45
Fig. 3-7	Screwing in objectives	46
Fig. 3-8	Changing the reflector module in the reflector insert.....	47
Fig. 3-9	Mounting the reflector insert.....	48
Fig. 3-10	Changing the mechanical stage, 75x50 R.....	48
Fig. 3-11	Adjusting the X- and Y-axis knob tension.....	49
Fig. 3-12	Changing the rotatable mechanical stage	49
Fig. 3-13	Centering the rotatable mechanical stage	50
Fig. 3-14	Adjusting ergonomic drive.....	51
Fig. 3-15	Adjusting the frictional momentum	52
Fig. 3-16	Changing the Pol rotary stage with click stop, attachable Pol object guide and stage clips ...	53
Fig. 3-17	Centering the Pol rotary stage	54
Fig. 3-18	Centering objectives.....	55
Fig. 3-19	Changing the motorized mechanical stage.....	56

Fig. 3-20	Plugging in the power cable of the motorized mechanical stage	56
Fig. 3-21	Mounting the condenser carrier	57
Fig. 3-22	Mounting the condenser	57
Fig. 3-23	Mounting the darkfield condenser	58
Fig. 3-24	Mounting the stage carrier	59
Fig. 3-25	Removing the HAL 50 halogen illuminator from the stand	60
Fig. 3-26	Inserting halogen lamp 12 V, 50 W	60
Fig. 3-27	Mounting the TL LED10 illuminator or RL LED10 illuminator.....	61
Fig. 3-28	Mounting the base plate.....	62
Fig. 3-29	Mounting the HAL 100.....	63
Fig. 3-30	Adjusting the HAL 100	64
Fig. 3-31	Changing the HAL 100	65
Fig. 3-32	Inserting the adjustment tool	66
Fig. 3-33	Mounting the HBO 100	67
Fig. 3-34	Power supply unit for HBO 100.....	67
Fig. 3-35	Adjustment tool	68
Fig. 3-36	Adjusting the HBO 100.....	68
Fig. 3-37	Mounting the illumination system Colibri 3	69
Fig. 3-38	Changing the LED modules in the Colibri 3 illumination system.....	70
Fig. 3-39	Mounting the binocular tube with intermediate plate	72
Fig. 3-40	Mounting the magnification changer	73
Fig. 3-41	Changing the filters in the reflector module FL P&C	74
Fig. 3-42	Mounting the filters and the color splitter.....	74
Fig. 3-43	Opening the module	75
Fig. 3-44	Changing the color filter	75
Fig. 3-45	Labeling the color splitter.....	76
Fig. 3-46	Mounting the polarizer D.....	76
Fig. 3-47	Mounting the low-power system	77
Fig. 3-48	Inserting the modulator disk in the 0.9/1.25 H condenser	78
Fig. 3-49	Mounting the slit-diaphragm	79
Fig. 3-50	Changing the PhC-DIC-PlasDIC diaphragm.....	79
Fig. 3-51	Changing the filter in the filter wheel transmitted light.....	80
Fig. 3-52	Lower stand part for HAL 50 illumination (proceed similarly for LED illumination).....	81
Fig. 3-53	Lower stand part for HAL 100 illumination	82
Fig. 3-54	External power supply unit for two lamps (front and back).....	82
Fig. 3-55	Power supply unit for HBO 100 (front and back).....	83
Fig. 4-1	Setting the inter-pupillary distance on the binocular tube.....	85
Fig. 4-2	Setting the viewing height on the binocular tube.....	85
Fig. 4-3	Microscope adjustment in transmitted light brightfield microscopy.....	88
Fig. 4-4	Adjusting the height stop on the condenser carrier.....	89
Fig. 4-5	Adjusting the height stop on the focusing drive.....	89
Fig. 4-6	Centering the darkfield diaphragm on the condenser, achromatic-aplanatic 0.9 H D PhC DIC	90
Fig. 4-7	Centering the annular phase diaphragm (light-colored, in the condenser) and the phase ring (dark-colored, in the object).....	94

Fig. 4-8	Components for the transmitted light DIC method.....	96
Fig. 4-9	Components for transmitted light polarization	99
Fig. 4-10	Determination of the polarization direction $n_{\gamma'}$ in a synthetic fiber	100
Fig. 4-11	Diagram of the Michel-Lévy color tables.....	102
Fig. 4-12	Components for circular polarization contrast	105
Fig. 4-13	Determining the optical character	110
Fig. 4-14	External power supply unit for HAL 100.....	112
Fig. 4-15	Setting the microscope in the reflected light brightfield	114
Fig. 4-16	Compensator slot 6x20 mm with C-DIC slider 6x20 mm.....	116
Fig. 4-17	TIC slider 6x20 mm	117
Fig. 4-18	Interference stripes.....	118
Fig. 4-19	Components for reflected light polarization	121
Fig. 4-20	Components for reflected light fluorescence	123
Fig. 5-1	Replacing the fuses in the stand	126
Fig. 5-2	Replacing fuses in the power supply unit.....	127

1 INTRODUCTION









1.1 Notes on instrument safety

The Axioscope 5/7/Vario microscopes were engineered, manufactured and tested in accordance with the DIN EN 61010-1 (IEC 61010-1) and IEC 61010-2-101 safety standards for electrical measuring, control and laboratory equipment.

The microscopes fulfill the requirements as stated in Directive 98/79/EC on in vitro diagnostic medical devices (IVDD) and bear the **CE** marking.





The present manual contains information and safety warnings with which the operator must comply.







The following warning, instructional and informational symbols are used in the manual:







	CAUTION Warns the operator of a possible danger.
	CAUTION Warns the operator of hot surfaces.
	CAUTION Warns the operator of the emission of UV radiation.
	CAUTION Warns the operator of the emission of LED radiation. LED class 3B, max. 30 mW, 365 - 625 nm, Avoid direct exposure to the beam. Avoid contact with the skin.
	CAUTION Warns the operator of crushing hazard.
	CAUTION Warns the operator to disconnect the instrument from the power supply before opening or doing any work on the instrument.
	ATTENTION This symbol indicates the risk of damage to the instrument or the system.
	NOTE This symbol indicates information or instructions which must be followed especially carefully.

The Axioscope 5/7/Vario microscopes and their original accessories may be used only for the microscopy procedures described in this operating manual.

The following guidelines are especially important:

	<p>CAUTION</p> <p>The microscope may only be plugged into an electrical outlet equipped with a safety contact. The safety feature must not be disabled by using an extension cord which does not have a protective ground conductor.</p>
	<p>CAUTION</p> <p>Whenever it becomes apparent that any of the safety mechanisms are out of order, the microscope must be switched off and protected from any inadvertent use. Please contact the ZEISS Service Department or the Carl Zeiss Microscopy Service before switching the microscope on again.</p>
	<p>CAUTION</p> <p>The stands are equipped with integrated power supply units. These units adapt to a voltage range of 100 to 240 V and a frequency range of 50 to 60 Hz. No further voltage adjustment is necessary on the microscope itself.</p> <p>The 12 V DC 100 W external power supply unit for HAL 100 covers a voltage range from 100 to 127 V AC and 200 to 240 V AC $\pm 10\%$, and a frequency range of 50 to 60 Hz. It adapts automatically to the applied voltage.</p> <p>The 24 V DC 30 W external power supply unit for Axioscope 5 Vario covers a voltage range from 100 V to 240 V and a frequency range of 50 to 60 Hz.</p> <p>The power supply units for the HBO 100 adapt to a voltage range from 100 to 240 V AC and a frequency range of 50 to 60 Hz. They adapt automatically to the applied voltage. No further voltage adjustment is necessary.</p> <p>Before you switch on the instrument, please verify that the voltage you are about to use is suitable.</p>
	<p>CAUTION</p> <p>Always disconnect the microscope from the power supply before you open it or change a fuse!</p> <p>Make sure that the fuses are suitable for the applied nominal current. Never use any makeshift fuses and do not short-circuit the fuse holders.</p>
	<p>CAUTION</p> <p>The microscopes do not have any special safety devices to protect users from acid or from potentially infectious, toxic, radioactive or other samples that may be hazardous to your health. Compliance with all statutory requirements, especially national accident prevention regulations, is required when handling such samples.</p>

	CAUTION Only authorized personnel are permitted to operate the instruments. The personnel must have been instructed about and be aware of the risks involved in using the microscope. The Axioscope is a precision instrument whose functionality can easily be damaged or even destroyed when handled improperly.
	CAUTION Operating the instrument in an area with a potentially explosive atmosphere is prohibited. It may be operated only on stable, non-flammable surfaces. Specimens must be disposed of appropriately in accordance with applicable statutory regulations and internal work instructions.
	CAUTION Gas discharge lamps, such as the HBO 100, emit ultraviolet radiation which may cause injuries to your eyes and skin. Never look directly into the beam and avoid exposing your skin directly to the beam. Never operate the microscope without the necessary safety equipment (e.g. special damping filters or the fluorescence protection screen). Gas discharge lamps have a high internal pressure when hot. Never change the lamps while they are still hot and always use protective gloves and masks when changing them.
	CAUTION Avoid any contact with the hot lamp case. Before you change a lamp, disconnect the instrument from the power supply and wait 15 minutes for the lamp to cool down.
	CAUTION When the lamp module (e.g. Colibri 3) is equipped with appropriate LED modules, or when a white light source coupled by a fluid light conductor is used, ultraviolet radiation may leak which can cause injury to your eyes and skin. Never look directly into the light and avoid exposing your skin directly to the light. Always use the appropriate safety equipment when operating the microscope.
	CAUTION Never look into the light beam of the illumination equipment - with or without optical instruments - not even if you just want to look at a specimen. Irreparable eye damage may occur!
	CAUTION Do not hold any flammable or easily combustible materials into the light beam.

	CAUTION The immersion fluid Immersol 518 N [®] is irritating to the skin. Avoid any contact with skin, eyes and clothes. Read the safety data sheets on Immersol 518 N [®] , Immersol 518 F [®] and Immersol W [®] carefully. If skin contact occurs, wash off with lots of water and soap. If eye contact occurs, flush with water immediately for at least 5 minutes. Seek medical assistance if irritation continues.
	CAUTION Dispose of immersion fluid Immersol 518 N [®] appropriately: Do not allow to contaminate surface water or get into drains.
	CAUTION For stands equipped with motorized focusing drives, there is a risk of fingers being crushed in the working area when the microscope stage is lowered. Do not reach into the area between the microscope stage/stage carrier/condenser carrier and the base of the stand while the stage is being lowered.
	ATTENTION The manufacturer assumes no liability for any use of the microscope, its assemblies or individual parts if these are used in a manner or for any purpose other than those described in this operating manual. This also applies to any maintenance or repair work not performed by authorized maintenance and repair personnel. Moreover, the warranty and any claims thereunder will be voided.
	ATTENTION Microscope lamps radiate a lot of heat which could damage the heat-sensitive fluorescence filters. Do not remove the heat protection filter when using a fluorescence filter; otherwise the fluorescence filter may not function properly.
	ATTENTION Dirt and dust may affect the microscope's performance. Protect it by using a dust cover when it is not in use. Always make sure that the instrument is switched off before covering it up.
	ATTENTION Closing or covering the ventilation slits may result in heat accumulation which could damage the instrument and even start a fire. Ensure that the ventilation slits are always kept open, uncovered and clear. Do not insert or drop anything into them or let anything fall into them.

	ATTENTION
	Always position equipment in a manner that allows easy disconnection from the power supply.
	ATTENTION
	Do not use a power supply cord with an inadequate rating.
	ATTENTION
	When using the HAL or HBO illuminators, a base plate for the Axioscope (000000-2202-526) is mandatory.
	ATTENTION
	Do not dispose of defective microscopes in the household waste. Comply with the applicable statutory regulations for their disposal. Specimens must also be disposed of appropriately in accordance with applicable statutory regulations and internal work instructions.

1.2 Warning labels on the microscopes

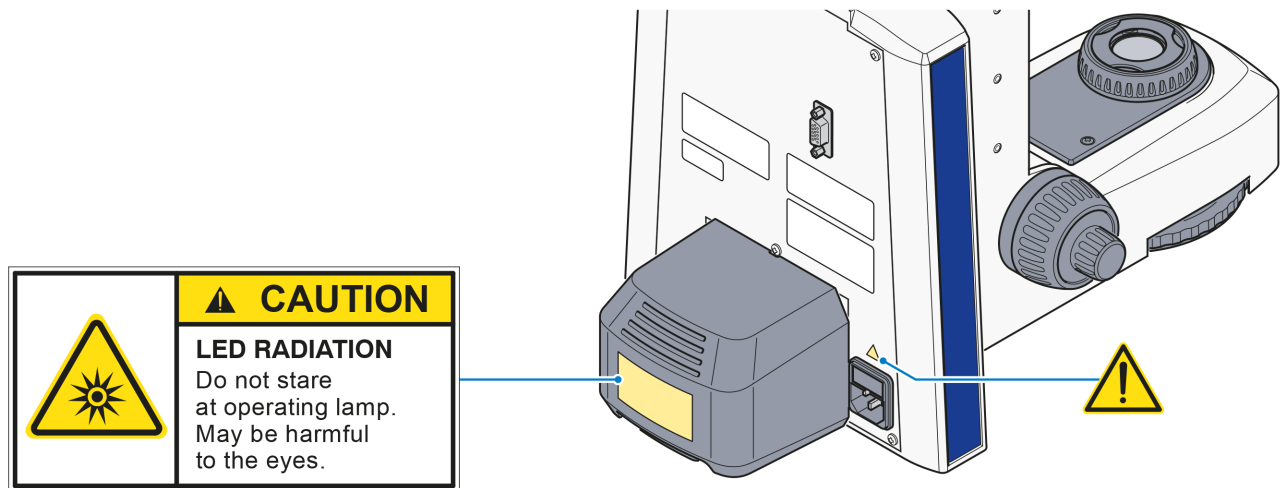

Fig. 1-1 Warning labels on microscopes with LED light source for transmitted light

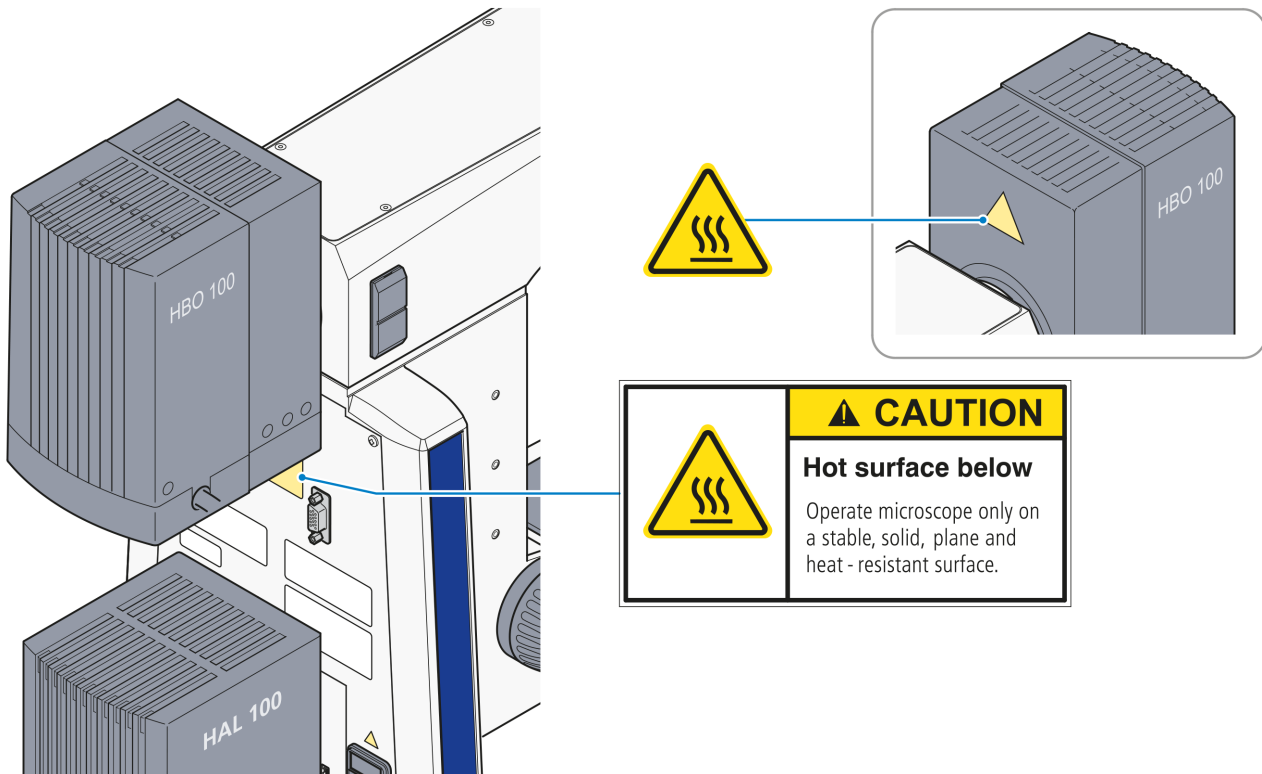

Fig. 1-2 Warning labels on microscopes with HAL 100 for transmitted light and HBO 100 for reflected light

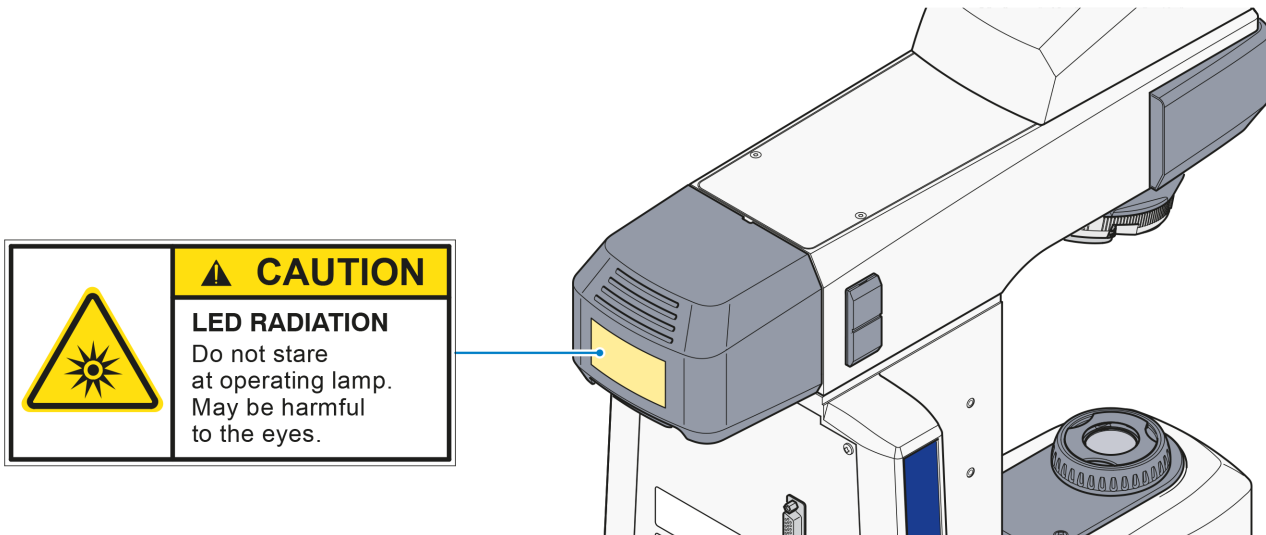

Fig. 1-3 Warning label on microscopes with LED light source for reflected light

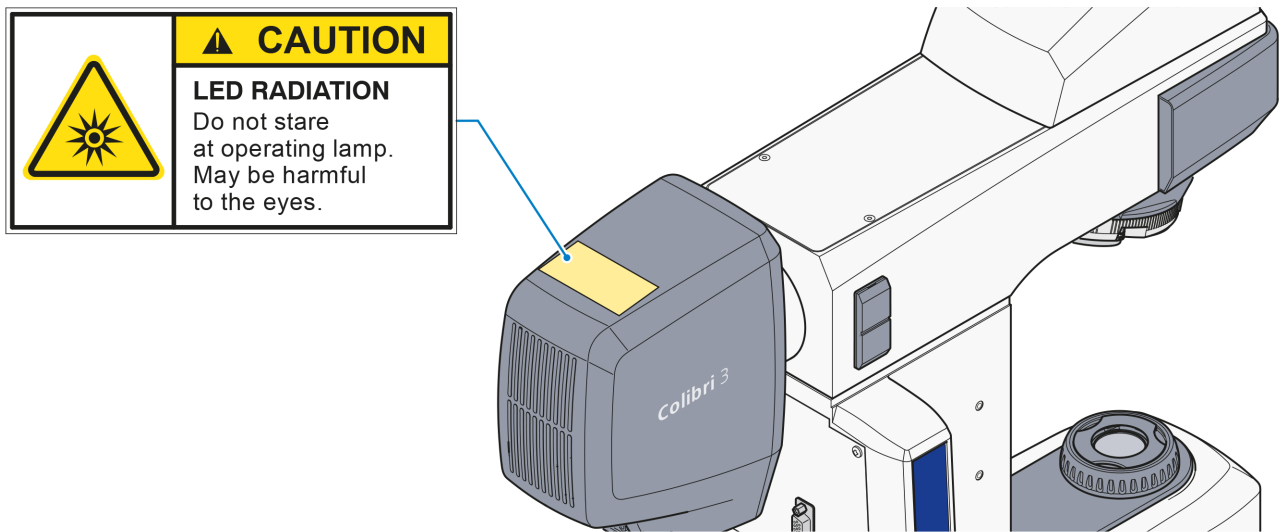

Fig. 1-4 Warning label on microscopes with Colibri 3 light source for reflected light

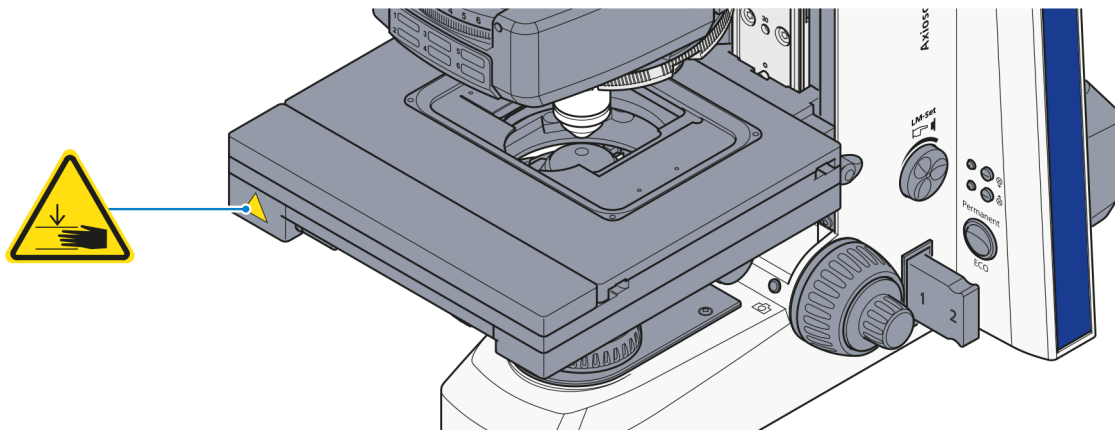

Fig. 1-5 Warning label on Axioscope 7 stand using the motorized 80x60 mechanical stage 80x60

1.3 Notes on the warranty

The manufacturer guarantees that the instrument is free of any material and workmanship defects upon delivery. If you become aware of any deficiencies, please contact us immediately and take all necessary precautions in order to avoid further damage. Upon notice of deficiencies it is up to the manufacturer's discretion to correct the deficiencies or to deliver a defect-free instrument. Defects due to ordinary wear and tear (especially on wearing parts) and to improper handling are not covered by our warranty.

The manufacturer is not liable for damage to the instrument due to incorrect operation, negligence or any other manipulation of the instrument, in particular due to the removal or replacement of instrument parts or due to the use of accessories from other manufacturers. This will immediately void the warranty.

No maintenance or repair work, except for the instances mentioned in the manual, may be performed on the microscopes. Only ZEISS service personnel or personnel authorized especially by ZEISS may perform repair work on the microscopes. In the event of malfunction of your instrument, please contact the ZEISS Microscopy Service Department (see page 131) or the ZEISS agency assigned to your country.

2 DESCRIPTION OF THE INSTRUMENT

2.1 Intended use

The Axioscope 5/7/Vario microscopes are universal microscopes designed especially for applications in biological and medical fields and for materials analysis.

Depending on the configuration of the microscope stand, they may be used with transmitted light only or with a combination of transmitted light and reflected light.

Typical areas of use for the Axioscope 5/7/Vario in biomedical applications include:

- medical analysis in laboratories, hospitals, physicians' practices,
- science and research (colleges, universities) in medical and biological fields,
- industrial applications (pharmacology, food technology),
- analysis of blood and tissue samples of the human body.

The Axioscope 5/7/Vario may also be used for materials analysis in:

- routine research in aerospace and metallographic laboratories,
- quality assurance and control in the automobile and mechanical engineering industries
- failure analysis in the electronics and semiconductor industries,
- The analysis of optical properties of minerals in geoscience studies, and
- morphology studies in the chemical, polymer and mineral exploration industries.

Depending on the accessories with which each instrument is equipped, the following microscopy and contrasting techniques can be performed:

Transmitted light

- Bright-field (BF)
- Dark-field (DF)
- Phase contrast (PhC)
- Differential interference contrast (DIC)
- PlasDIC
- Polarization (Pol): orthoscopy and conoscopy

Reflected light

- Bright-field (BF)
- Dark-field (DF)
- Differential interference contrast (DIC)
- Circular differential interference contrast/total interference contrast (C-DIC/TIC)
- Fluorescence
- Polarization (Pol)

The binocular photo tubes can be connected via a special adapter with a microscopy camera, a reflex camera or a digital/video camera for documentation purposes. An Infinity Space Camera Port (ISCP) camera can be used when working with transmitted light.

2.2 Technical data

Dimensions (length x width x height)

Microscope stand for Axioscope 5/7.....	approx. 293.5 mm x 240 mm x 367.5 mm
Microscope stand for Axioscope Vario.....	approx. 429 mm x 458.5 mm x 700 mm

Weight

Microscope stand for Axioscope 5/7 (depending on stand configurations and accessories).....	approx. 14 to 20 kg
Microscope stand for Axioscope Vario.....	approx. 32 kg

Ambient conditions

Shipping (in packaging):

Permissible ambient temperature.....	-40 to +70 °C
Permissible humidity (no condensation)	max. 75% at 35 °C

Storage:

Permissible ambient temperature.....	+10 to +40 °C
Permissible humidity (no condensation)	max. 75% at 35 °C

Operation:

Permissible ambient temperature.....	+10 to +40 °C
Permissible relative humidity (no condensation).....	max. 75% at 35 °C
Highest permitted altitude of use	max. 2000 m
Air pressure	800 hPa to 1060 hPa
Degree of pollution.....	2

Operational specifications

Operational area	Closed rooms
Protective class.....	I
Protection type.....	IP 20
Electrical safety.....	in accordance with DIN EN 61010-1 (IEC 61010-1) in conjunction with CSA and UL regulations
Overvoltage category.....	II
RFI suppression.....	conforming to EN 55011 Class B
Noise immunity	conforming to DIN EN 61326/A1
Mains voltage for the Axioscope 5/7 with internal power supply unit.....	100 to 240 V
Mains voltage for the Axioscope Vario with external power supply unit	100 to 240 V
Mains frequency.....	50 to 60 Hz
Power consumption of the Axioscope 5 with internal power supply unit.....	60 VA
Power consumption of the Axioscope 7 with internal power supply unit.....	100 VA
Power consumption of the Axioscope Vario with external power supply unit	30 VA

HBO 100 W power supply unit

Range of application	indoor
Protection class	I
Protection type	IP 20
Mains voltage	100 VAC ... 240 VAC No voltage adjustment required
Mains frequency	50 to 60 Hz
Power consumption with HBO 103 in operation	155 VA

Fuses in accordance with IEC 127

Axioscope 5/7 microscope stand for LED illumination in transmitted light:	2 T 3.15 A/H, 5x20 mm
Axioscope 5/7 microscope stand for HAL 50 illumination in transmitted light:	2 T 3.15 A/H, 5x20 mm
HBO 100 W power supply unit	T 2.0 A/H, 5x20 mm
12 V DC 100 W external power supply unit	2 T 5.0 A/H, 5x20 mm

Light sources

LED illumination transmitted light/reflected light	
Power consumption	max. 10 W
Adjustment of light source	continuous approx. 10 to 800 mA
Halogen lamp	
Adjustment of light source	infinitely variable from approx. 3 to 12 V
Halogen lamp	
Adjustment of light source	infinitely variable from approx. 3 to 12 V
Mercury vapor short arc lamp	
Power consumption for HBO 103 W/2	100 W
Colibri 3 illumination system	
Power consumption	15 W

Axioscope 5/7/Vario

Stand with manual/motorized stage focusing	
Coarse drive	approx. 4 mm/rotation
Fine drive	approx. 0.4 mm/rotation; approx. 4 µm scale intervals
Lifting range	approx. 25 mm
Height stop	mechanically variable
Condenser 0.9/1.25 H with optional modulator disk	
	for bright-field, dark-field and phase contrast 1, 2, 3 or PlasDIC
Manual objective change	via nosepiece, 6-positions, M27
Manual reflector module change	via reflector slider, 2-positions coded, reflector turret 4-positions coded or 6-positions coded

2.3 Interface diagram

The following figure shows a diagram of the microscope's hardware interfaces. The Axioscope 5 stand Bio-TL/RL with LED/HAL illumination serves as the example.

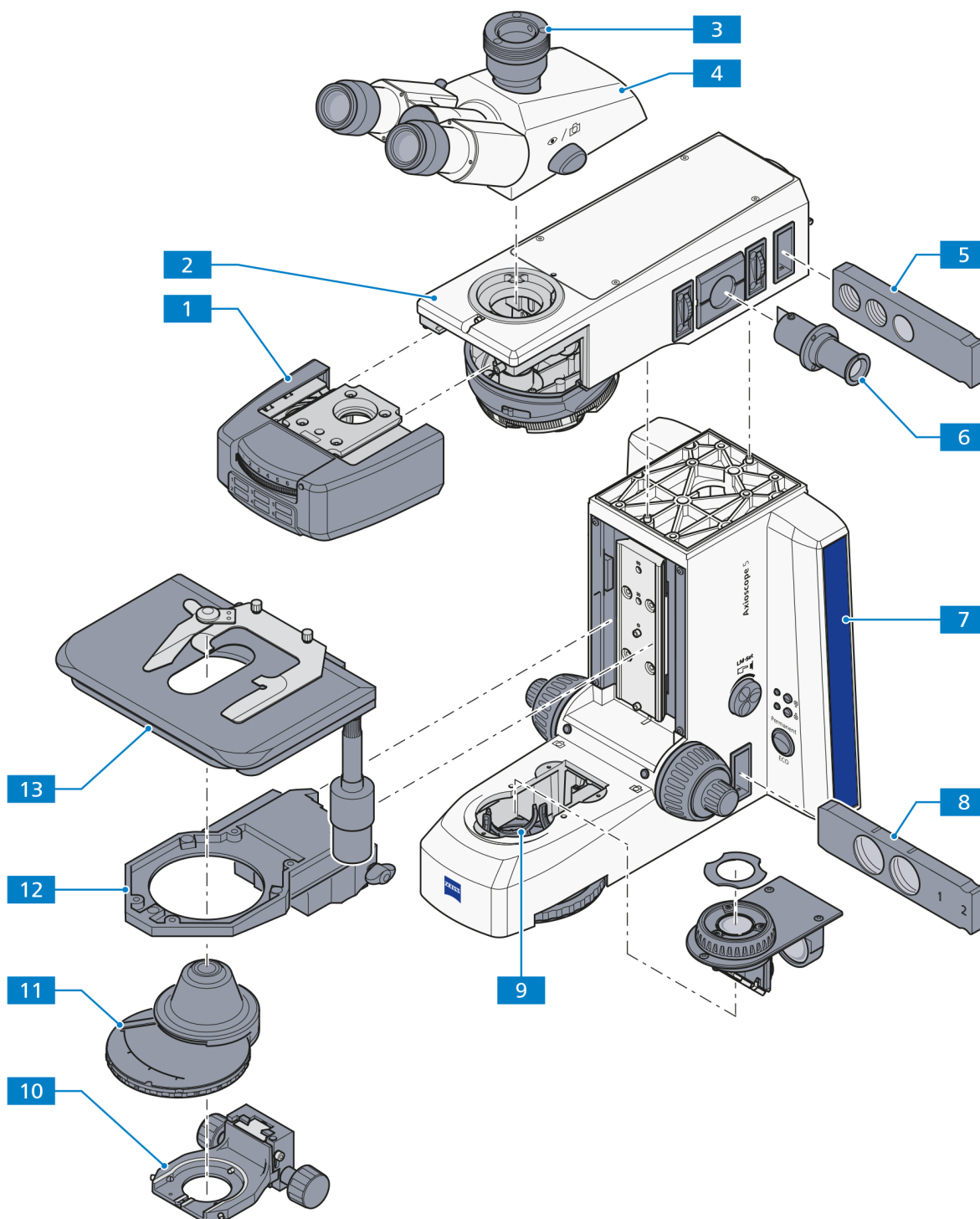

Fig. 2-1 Interface diagram (example: Axioscope 5 stand, Bio-TL/RL)

Key to Fig. 2-1:

- 1 Reflector turret
- 2 Upper part of the stand
- 3 Camera interface 60N on the photo tube
- 4 Tube/photo tube
- 5 Filter slider for reflected light
- 6 Adjustment tool
- 7 Lower part of the stand
- 8 Filter slider for transmitted light
- 9 Filter wheel for transmitted light
- 10 Condenser carrier
- 11 Condenser
- 12 Stage carrier
- 13 Stage

2.4 Controls and functional elements on the microscope

2.4.1 Stand models

Eight stand models are available in the delivery program:

- 1. Axioscope 5 stand HAL 50 (430035-9032-000)
- 2. Axioscope 5 stand, Bio-TL (430035-9201-000)
- 3. Axioscope 5 stand, Bio-TL/RL (430035-9061-000)
- 4. Axioscope 5 stand, Pol-TL (430035-9261-000)
- 5. Axioscope 5 stand, Pol-TL/RL (430035-9291-000)
- 6. Axioscope 5 stand, Mat-TL/RL (430035-9121-000)
- 7. Axioscope 7 stand, Mat-TL/RL, motorized (430035-9330-000)
- 8. Axioscope 5 Vario material stand (430035-9150-000)

2.4.2 Axioscope 5 stands, Bio-TL

Transmitted light stands for bioscience equipped with the following main components:

1. Version 1 (430035-9032-000): HAL 50 halogen illumination
Version 2 (430035-9201-000): LED 10 W-TL illumination or optionally HAL 100 halogen illumination using an external power supply
2. Nosepiece 6-positions M 27 HF, coded
3. Mechanical stage 75x50 R
4. Binocular photo tube 30x/23 (50:50), reversed image
5. Eyepiece E-PL 10x/23 GW foc.
6. Condenser 0.9/1.25H
7. Coded changeable reflector turrets and reflector slider

Key to Fig. 2-2:

- 1 Eyepieces
- 2 Binocular tube part
- 3 Binocular tube/photo tube (with mounted Axiocam 208, optionally)
- 4 Transmitted light stand
- 5 Transmitted light illuminator
- 6 Intensity/LM knob for light intensity and Light Manager function (LM)
- 7 Indicator light for transmitted light
- 8 Permanent/ECO mode switch
- 9 Filter slider transmitted light
- 10 Focusing drive – fine adjustment (left & right)
- 11 Focusing drive – coarse adjustment (left & right)
- 12 Coaxial knurled knob for adjusting the mechanical stage in direction Y
- 13 Coaxial knurled knob for adjusting the mechanical stage in direction X
- 14 Snap buttons
- 15 Nosepiece
- 16 6-position filter wheel (operable from left & right)
- 17 Field diaphragm
- 18 Condenser with aperture diaphragm and centering screws (with optional modulator disk)
- 19 Knurled knob for adjusting the condenser vertically (left & right)
- 20 Stage carrier
- 21 Condenser carrier
- 22 Release lever for height stop on focusing drive
- 23 Main switch I/O
- 24 Mechanical stage with dual specimen holder

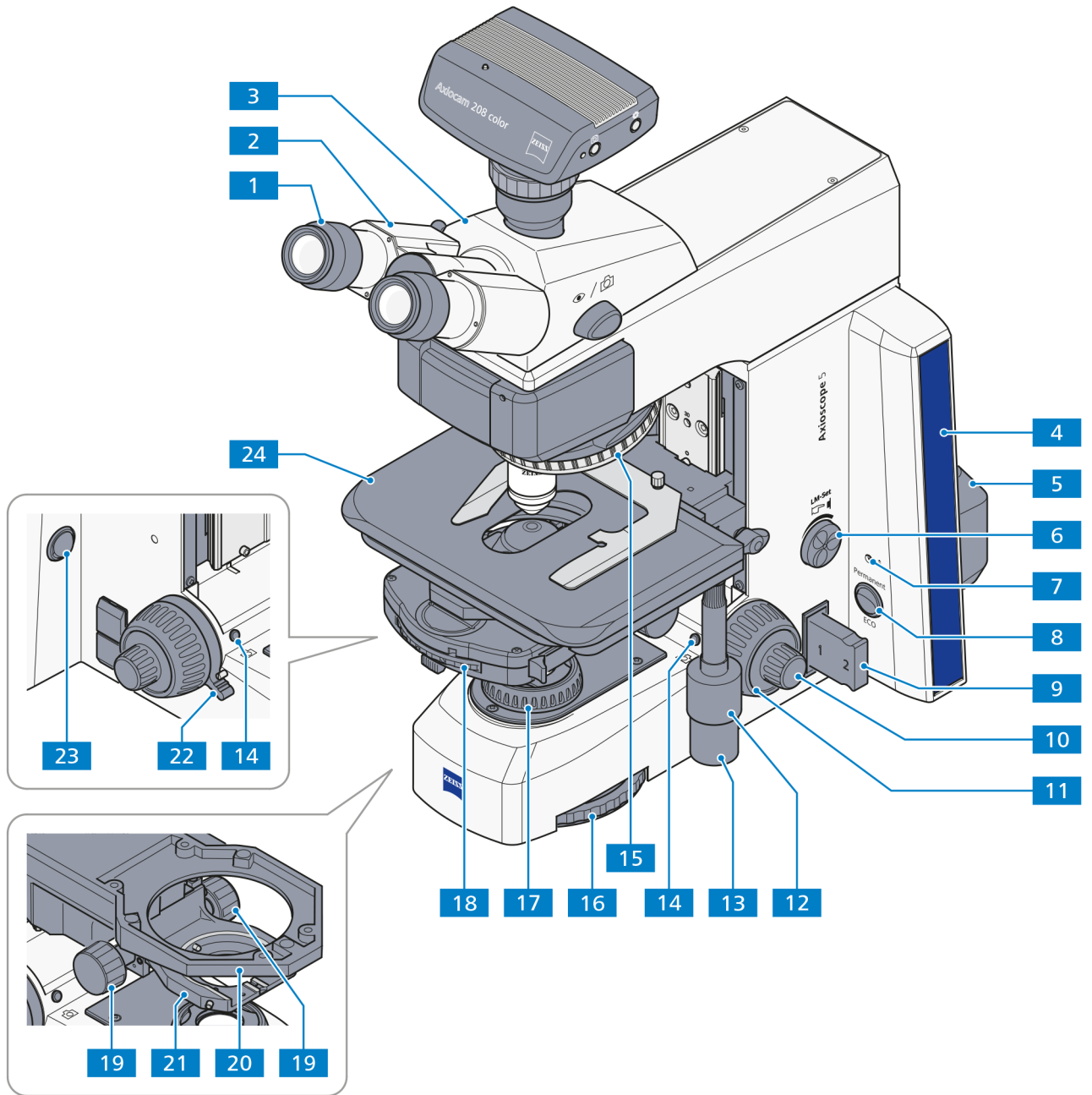

Fig. 2-2 Controls and functional elements of the Axioscope 5 stands, Bio-TL

2.4.3 Axioscope 5 stand, Bio-TL/RL

Transmitted and reflected light fluorescence stand for bioscience equipped with the following main components:

1. LED 10 W-TL illumination or optionally with HAL 100 halogen illumination using an external power supply for transmitted light applications
2. Colibri 3, HBO 100, HXP illumination for reflected light fluorescence applications
3. Nosepiece 6-positions M27 HF, DIC, coded
4. Mechanical stage 75x50 R
5. Binocular photo tube 30x/23 (50:50) reversed image
6. Eyepiece E-PL 10x/23 GW foc.
7. Condenser 0.9/1.25H
8. Coded changeable reflector turret or reflector slider

Key to Fig. 2-3:

- 1 Eyepieces
- 2 Binocular tube part
- 3 Binocular tube/photo tube (with mounted Axiocam 208 or Axiocam 202, optionally)
- 4 Field diaphragm (as slider)
- 5 Adjustment tool
- 6 Aperture diaphragm (as slider) or FL attenuator
- 7 Filter slider for reflected light
- 8 Reflected light illuminator
- 9 Transmitted and reflected light stand
- 10 Intensity/LM knob for light intensity and Light Manager function (LM)
- 11 Transmitted light illuminator
- 12 Indicator light for reflected light
- 13 Reflected light (RL) button
- 14 Transmitted light (TL) button
- 15 Indicator light for transmitted light
- 16 Permanent/ECO mode switch
- 17 Filter slider transmitted light
- 18 Focusing drive – fine adjustment (left & right)
- 19 Focusing drive – coarse adjustment (left & right)
- 20 Coaxial knurled knob for adjusting the mechanical stage in direction Y
- 21 Coaxial knurled knob for adjusting the mechanical stage in direction X
- 22 Snap buttons
- 23 Nosepiece
- 24 6-position filter wheel (operable from left & right)
- 25 Field diaphragm
- 26 Condenser with aperture diaphragm and centering screws (with optional modulator disk)
- 27 Knurled knob for adjusting the condenser vertically (left & right)
- 28 Stage carrier
- 29 Condenser carrier
- 30 Release lever for height stop on focusing drive
- 31 Main switch I/O
- 32 Mechanical stage with dual specimen holder
- 33 Knurled wheel for switching the reflector turret position
- 34 Reflector turret (for replaceable reflector inserts)

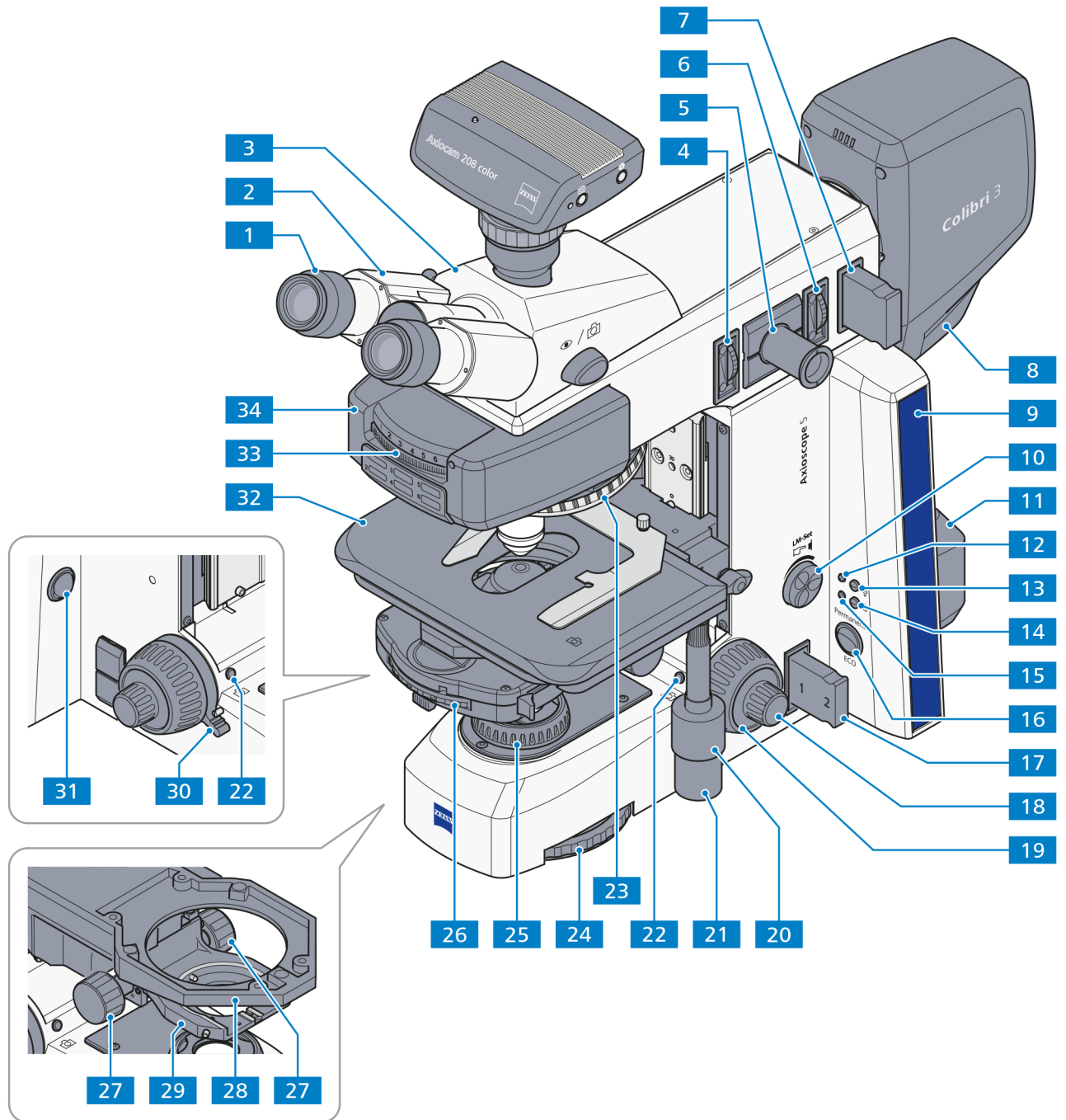

Fig. 2-3 Controls and functional elements of the Axioscope 5 stand, Bio-TL/RL

2.4.4 Axioscope 5 stand, Pol-TL/RL

Transmitted and reflected light stand for polarization equipped with the following main components:

1. LED 10 W-TL illumination or optionally with HAL 100 halogen illumination using an external power supply for transmitted light applications
2. LED 10 W-RL illumination for reflected light applications
3. Nosepiece 6-positions M27: 5-positions HF/DF/Pol, centerable and 1x HF/DF/DIC fixed, coded
4. Pol rotary stage, 360° with 45° click stops (freely definable)
5. Binocular photo tube 30x/23 (100:0/0:100), reversed image
6. E-PL 10x/23 GW foc. Pol Eyepiece with reticle
7. Pol condenser 0.9 H
8. Mount for polarization slider A 14x40 mm, d = 36 mm
9. Polarizer D, 90° rotatable, removable
10. Quartz depolarizer with tube-lens for Axioscope tubes
11. Coded changeable reflector turret or reflector slider

Key to Fig. 2-4:

- 1 Eyepieces
- 2 Binocular tube part
- 3 Binocular tube/photo tube (with mounted Axiocam 208, optionally)
- 4 Slot for polarizer slider A 60x30 mm
- 5 Field diaphragm (as slider)
- 6 Aperture diaphragm (as slider)
- 7 Filter slider for reflected light
- 8 Reflected light illuminator
- 9 Transmitted and reflected light stand
- 10 Intensity/LM knob for light intensity and Light Manager function (LM)
- 11 Transmitted light illuminator
- 12 Indicator light for reflected light
- 13 Reflected light (RL) button
- 14 Transmitted light (TL) button
- 15 Indicator light for transmitted light
- 16 Permanent/ECO mode switch
- 17 Filter slider transmitted light
- 18 Focusing drive – fine adjustment (left & right)
- 19 Focusing drive – coarse adjustment (left & right)
- 20 Snap buttons
- 21 Nosepiece
- 22 6-position filter wheel (operable from left & right)
- 23 Field diaphragm
- 24 Condenser with aperture diaphragm and centering screws (with optional modulator disk)
- 25 Knurled knob for adjusting the condenser vertically (left & right)
- 26 Polarizer
- 27 Condenser carrier
- 28 Stage carrier
- 29 Release lever for height stop on focusing drive
- 30 Main switch I/O
- 31 Pol rotary stage
- 32 Knurled wheel for switching the reflector turret position
- 33 Reflector turret (for replaceable reflector inserts)

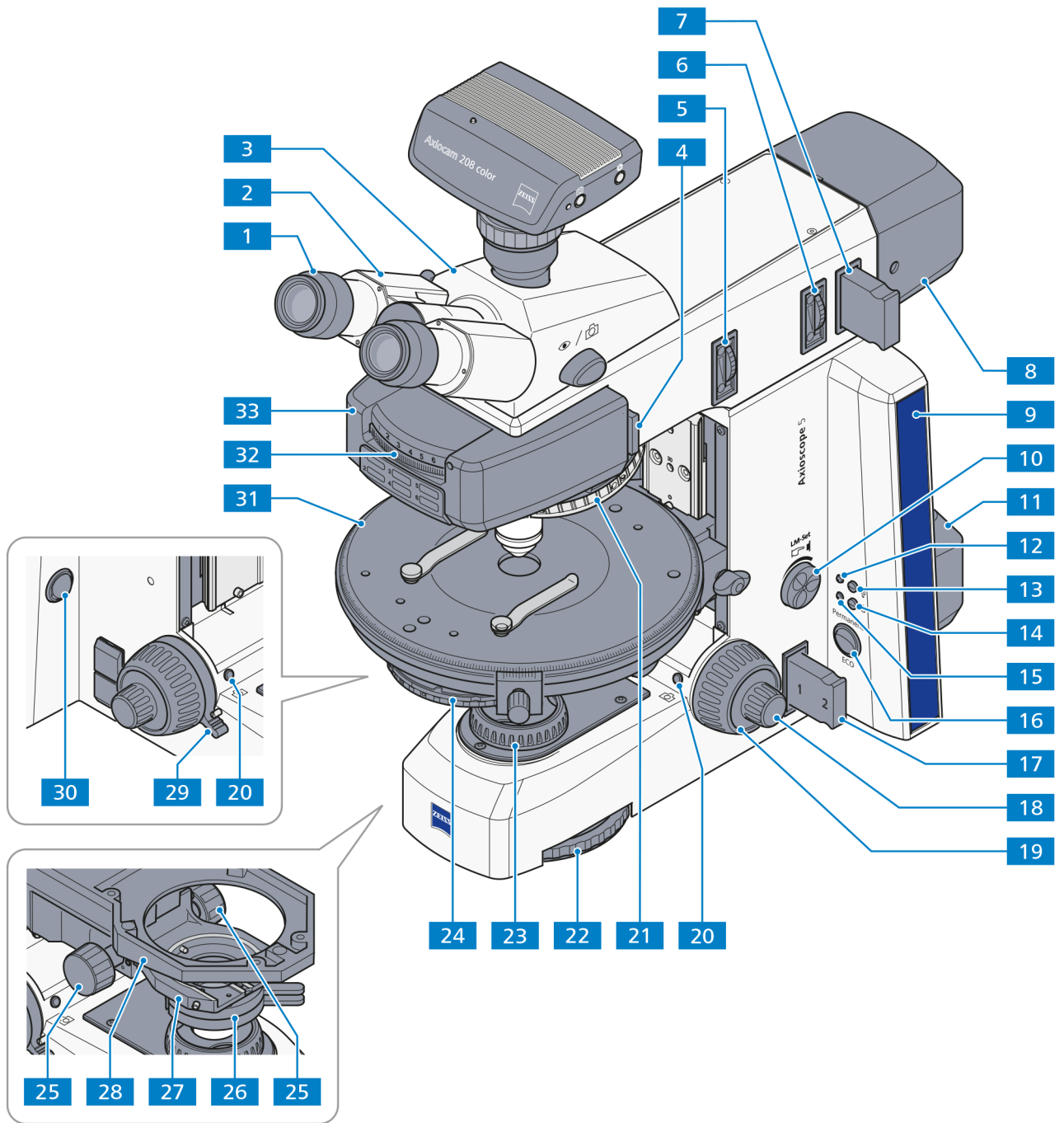

Fig. 2-4 Controls and functional elements of the Axioscope 5 stand, Pol-TL/RL

2.4.5 Axioscope 5 stand, Mat-TL/RL

Transmitted and reflected light stand for material equipped with the following main components:

1. LED 10 W-TL illumination or optionally with HAL 100 halogen illumination using an external power supply for transmitted light applications
2. LED 10 W-RL illumination for reflected light applications
3. Nosepiece 6-positions M27 HF/DF/DIC, coded
4. Mechanical stage 75x50 R
5. Binocular photo tube 20x/23 (100:0/0:100), upright image with sliding prism
6. Eyepiece E-PL 10x/23 GW foc.
7. Condenser 0.9/1.25H
8. Mount for polarization slider A 14x40 mm d = 36 mm
9. Coded changeable reflector turret or reflector slider

Key to Fig. 2-5:

- 1 Eyepieces
- 2 Binocular tube part
- 3 Binocular tube/photo tube (with mounted Axiocam 208, optionally)
- 4 Slot for polarizer slider A 60x30 mm
- 5 Field diaphragm (as slider)
- 6 Aperture diaphragm (as slider)
- 7 Filter slider for reflected light
- 8 Reflected light illuminator
- 9 Transmitted and reflected light stand
- 10 Intensity/LM knob for light intensity and Light Manager function (LM)
- 11 Transmitted light illuminator
- 12 Indicator light for reflected light
- 13 Reflected light (RL) button
- 14 Transmitted light (TL) button
- 15 Indicator light for transmitted light
- 16 Permanent/ECO mode switch
- 17 Filter slider transmitted light
- 18 Focusing drive – fine adjustment (left & right)
- 19 Focusing drive – coarse adjustment (left & right)
- 20 Coaxial knurled knob for adjusting the mechanical stage in direction Y
- 21 Coaxial knurled knob for adjusting the mechanical stage in direction X
- 22 Snap buttons
- 23 Nosepiece
- 24 6-position filter wheel (operable from left & right)
- 25 Field diaphragm
- 26 Condenser with aperture diaphragm and centering screws (with optional modulator disk)
- 27 Knurled knob for adjusting the condenser vertically (left & right)
- 28 Stage carrier
- 29 Condenser carrier
- 30 Release lever for height stop on focusing drive
- 31 Main switch I/O
- 32 Mechanical stage with dual specimen holder
- 33 Knurled wheel for switching the reflector turret position
- 34 Reflector turret (for replaceable reflector inserts)

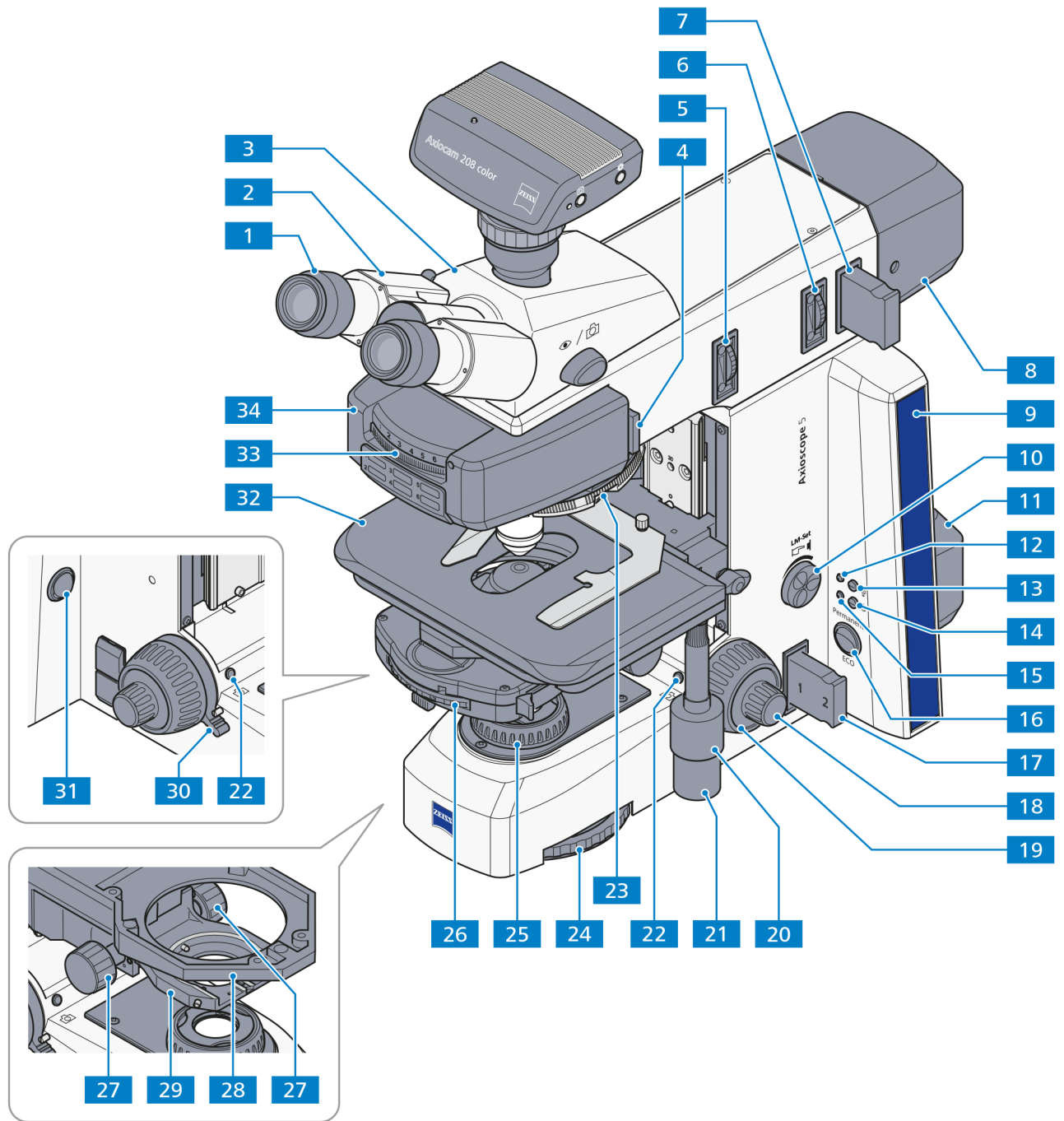

Fig. 2-5 Controls and functional elements of the Axioscope 5 stand, Mat-TL/RL

2.4.6 Axioscope 7 stand, Mat-TL/RL mot.

Transmitted and reflected light stand for material equipped with the following main components:

1. LED 10 W-TL illumination or optionally with HAL 100 halogen illumination using an external power supply for transmitted light applications
2. LED 10 W-RL illumination for reflected light applications
3. Nosepiece 6-positions M27 HF/DF/DIC, coded
4. Motorized 80x60 mechanical stage
5. Binocular photo tube 20x/23 (100:0/0:100), upright image with sliding prism
6. Eyepiece E-PL 10x/23 GW foc.
7. Condenser 0.9/1.25H
8. Mount for polarization slider A 14x40 mm d = 36 mm
9. Coded changeable reflector turret or reflector slider

Key to Fig. 2-6:

- 1 Eyepieces
- 2 Binocular tube part
- 3 Binocular tube/photo tube (with mounted Axiocam 208, optionally)
- 4 Slot for polarizer slider A 60x30 mm
- 5 Field diaphragm (as slider)
- 6 Aperture diaphragm (as slider)
- 7 Filter slider for reflected light
- 8 Reflected light illuminator
- 9 Transmitted and reflected light stand
- 10 Intensity/LM knob for light intensity and Light Manager function (LM)
- 11 Transmitted light illuminator
- 12 Indicator light for reflected light
- 13 Reflected light (RL) button
- 14 Transmitted light (TL) button
- 15 Indicator light for transmitted light
- 16 Permanent/ECO mode switch
- 17 Filter slider for transmitted light
- 18 Focusing drive – fine adjustment (left & right)
- 19 Focusing drive – coarse adjustment (left & right)
- 20 Snap button
- 21 Nosepiece
- 22 6-position filter wheel (operable from left & right)
- 23 Field diaphragm
- 24 Condenser with aperture diaphragm and centering screws (with optional modulator disk)
- 25 Knurled knob for adjusting the condenser vertically (left & right)
- 26 Stage carrier
- 27 Condenser carrier
- 28 Stage control button
- 29 Main switch I/O
- 30 Mechanical stage 80x60 mot. with dual specimen insert
- 31 Knurled wheel for switching the reflector turret position
- 32 Reflector turret (for replaceable reflector inserts)

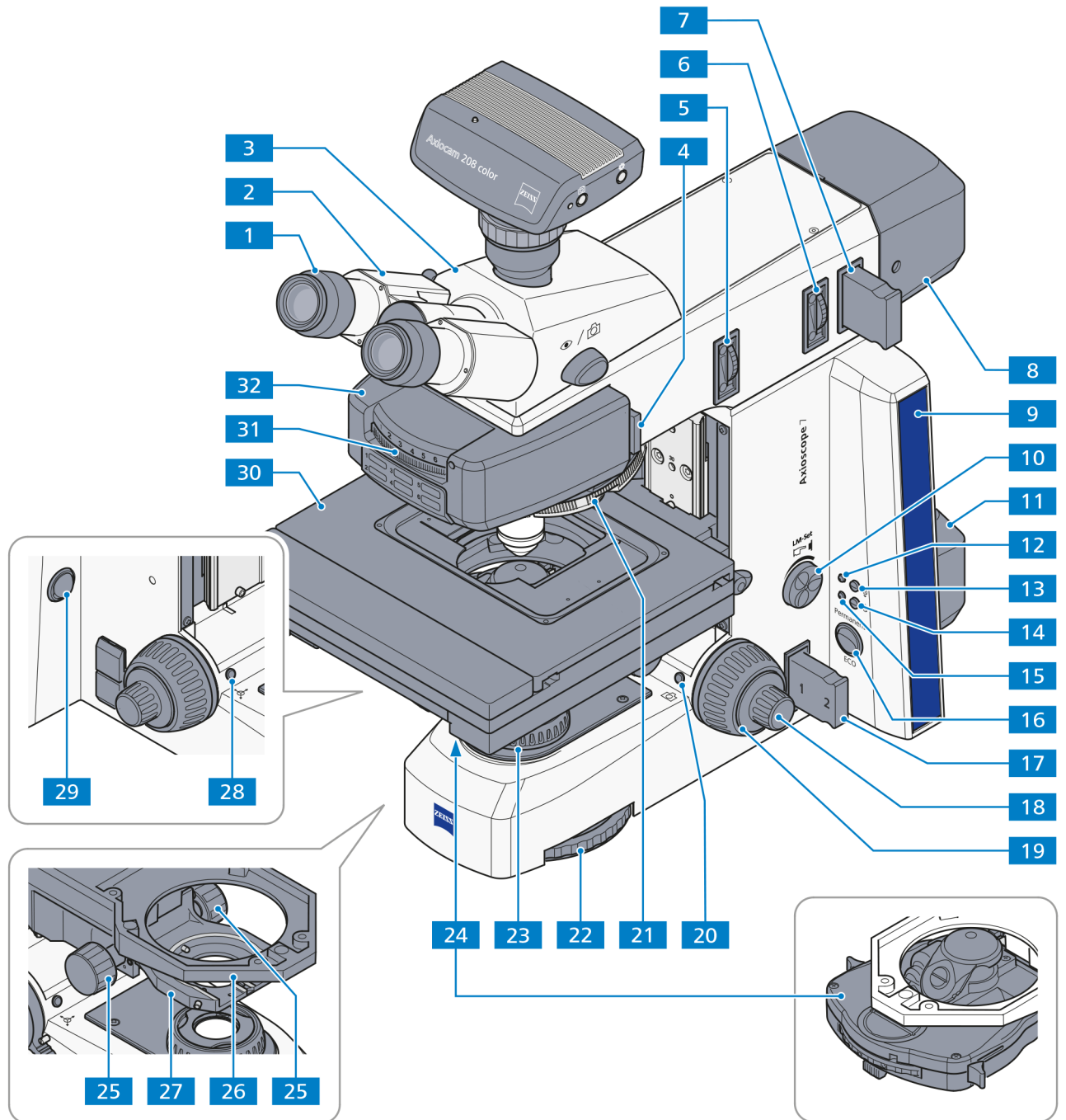

Fig. 2-6 Controls and functional elements of the Axioscope 7 stand, Mat-TL/RL mot.

2.4.7 Axioscope 5 Vario material stand

Transmitted and reflected light stand for material, equipped with the following main components:

1. Upper stand part including reflected-light illumination LED 10 W, with interface for HAL / HBO / HXP
2. Focusing gear box Axioscope Vario, 15 mm focus lift
3. Nosepiece 6-positions HF/DF/DIC, coded
4. Binocular photo tube 20x/23 (100:0/0:100), upright image with sliding prism
5. Eyepiece E-PL 10x/23 GW foc.
6. Coded changeable reflector turret or reflector slider
7. Stand column 560 mm with crank for vertical adjustment
8. Stage carrier and base plate

Key to Fig. 2-7:

- 1 Eyepieces
- 2 Binocular tube part
- 3 Binocular tube/photo tube (with mounted AxioCam 208, optionally)
- 4 Release lever for vertical adjustment
- 5 Stand column Axioscope Vario 560 mm
- 6 Hand wheel for vertical adjustment
- 7 Slot for polarizer slider A 60x30 mm
- 8 Field diaphragm (as slider)
- 9 Aperture diaphragm (as slider)
- 10 Filter slider for reflected light
- 11 Reflected light illuminator
- 12 Intensity/LM knob for light intensity and Light Manager function (LM)
- 13 Focusing drive – coarse adjustment
- 14 Focusing drive – fine adjustment
- 15 Snap button
- 16 Indicator light for reflected light
- 17 Permanent/ECO mode switch
- 18 Base plate
- 19 Stage carrier, H=140 mm
- 20 Nosepiece
- 21 Knurled wheel for switching the reflector turret position
- 22 Reflector turret (for replaceable reflector inserts)

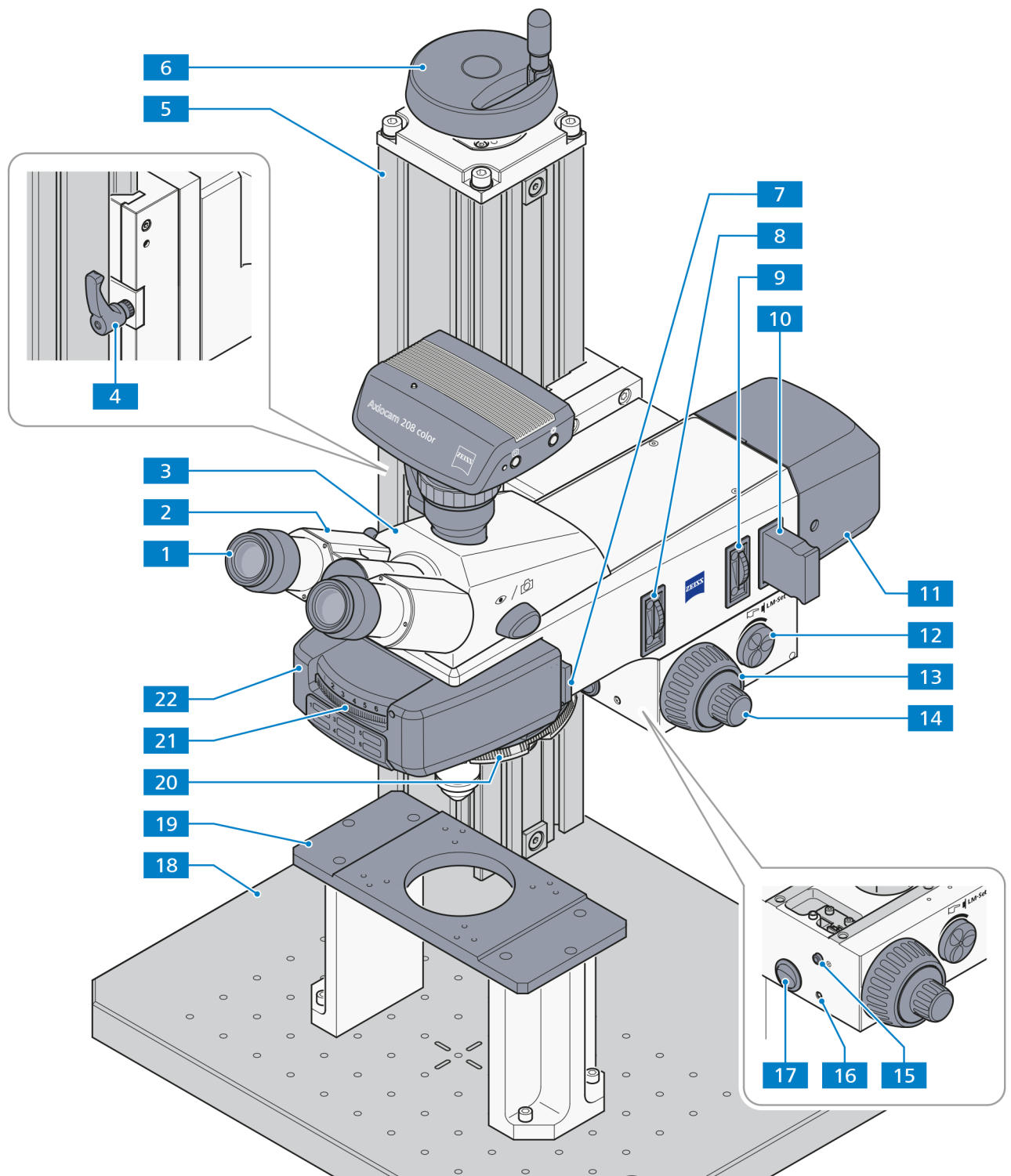



Fig. 2-7 Controls and functional elements of the Axioscope 5 Vario material stand

2.4.8 Functions of stands keys and display elements

For the location of the keys and display elements on your stand, refer to sections 2.4.2 - 2.4.7.

	NOTE
Each time the microscope is switched on, the first setting of parfocal value for any nosepiece position will clear the parfocal settings for ALL nosepiece positions.	

Key	Availability			Action	Functionality/Description
	Axioscope 7 mot.	Axioscope 5	Axioscope 5 Vario		
Main switch I/O (see Fig. 2-6/29)	Yes	Yes	Yes	I = on; O = off	Switches the microscope on/off
Permanent/ECO switch (see Fig. 2-6/16)	Yes	Yes	Yes	Switch:	Switches between Permanent (continuous) mode and ECO mode of the microscope illumination: - Permanent mode active: illumination is continuously switched on. - ECO mode active: illumination switches off after 15 minutes without action.
Indicator light (see Fig. 2-6/12 and 15)	Yes	Yes	Yes	Blinking ***:	Indicates microscope function (normal/setting)
RL/TL button (see Fig. 2-6/13 and 14)	Yes	Option	No	Short press *:	Switches RL/TL illumination alternately on/off. The respective indicator light is continuously illuminated. Second press to the RL/TL button to turn off/on the illumination (the indicator light not affected).
Intensity/LM knob (see Fig. 2-6/10)	Yes	Yes	Yes	Turn:	Controls the light intensity of the active light source
				Short press *:	Repeated short pressing switches a single LED or all LEDs of the Colibri 3 together on or off (if Colibri 3 is connected).
				Long press **::	Saves the set light intensity. During this action, the indicator light blinks twice in GREEN and the image background appears BLACK for 300 ms (this does not apply to halogen illumination).
				Long press for 20 s:	Activates the factory default settings (enables Light Manager, sets light intensity to the initial value, clears all saved parfocal positions). When the knob is pressed, the indicator light starts blinking in RED after 3 s until 20 s is reached. After 20 s, the indicator light blinks in GREEN. Then release the knob. The indicator light turns to GREEN permanently if the system reset is done. After factory default reset, need re-power on the system.

* Short press: hold less than 1 second, then release.

** Long press: hold at least 1.5 seconds.

*** BLINK: the indicator light alternately goes on/off at 500 ms intervals.

Key	Availability			Action	Functionality/Description
	Axioscope 7 mot.	Axioscope 5	Axioscope 5 Vario		
Left Snap button (see Fig. 2-5/22) (if AxioCam attached)	No	Yes	No	Short press *:	Snaps an image
				Long press **:	Starts video recording; another short press is required to stop recording.
Right Snap button (see Fig. 2-6/20) (if AxioCam attached)	Yes	Yes	Yes	Short press:	Snaps an image; when the snap is completed, the monitor display turns BLACK for 50 ms.
				Long press **:	Starts video recording; another short press is required to stop recording.
Snap button + Intensity/LM knob (see Fig. 2-6/20+10)	Yes	Yes	Yes	Long press **::	Enables/disables the Light Manager: - Disabling: The indicator light blinks GREEN / ORANGE / GREEN in sequence. - Enabling: The indicator light blinks GREEN / GREEN / GREEN in sequence.
Stage control button on the left (see Fig. 2-6/28)	Yes	No	No	Short press *:	Switches between XY stage control and Z axis control via focus drives If Z axis control is active: - the indicator light lights in GREEN - the left or right fine focusing drive knobs are controlled for slow Z-movement (focusing) - the left and right coarse focusing drive knobs are controlled for fast Z-movement (focusing) If XY stage control is active: - the indicator light blinks ORANGE - the left focus drive knobs (fine or coarse) control Y movement (slow or fast) of the stage - the right focus drive knobs (fine or coarse) controls X movement of (slow or fast) the stage
				Long press **::	Records the parfocal position. 1. the LED shuts off for 300 ms (darkness indicates action to user) For halogen illumination: Do NOT shut off the light. 2. the indicator light blinks twice in GREEN
Right snap button + Stage control button on left (see Fig. 2-6/20+28)	Yes	No	No	Press simultaneously	Load/unload
				Press simultaneously again	Load/unload

* Short press: hold less than 1 second, then release.

** Long press: hold at least 1.5 seconds.

*** BLINK: the indicator light alternately turns on/off at 500 ms intervals

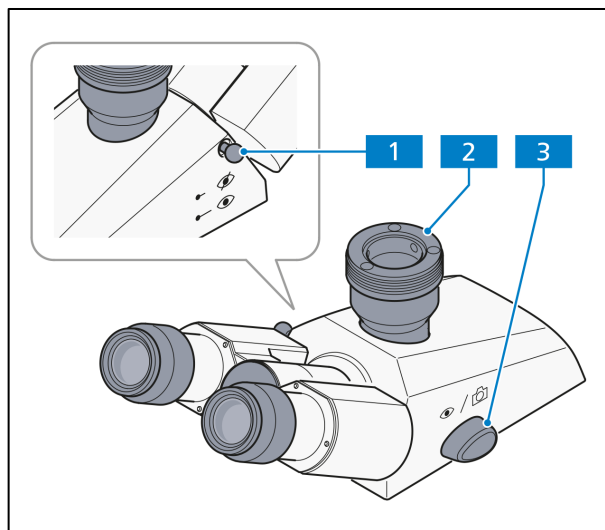

Fig. 2-8 Binocular photo tube

- Push-pull rod (Fig. 2-8/1) pushed in:
Eyepiece shutter is closed.
- Push-pull rod (Fig. 2-8/1) pulled out:
Eyepiece shutter is open.
- Whenever you want to take photos with a long exposure time, we recommend that you block any ambient light from entering the eyepieces by using the tube shutter or the eyepiece cover (included in the dust protection kit). If neither is available, remove the eyepiece and place the included dust protection caps over the eyepiece barrels.
- Vary eyepiece distance by moving the eyepiece barrels apart or together.

2.5 Controls and functional elements on microscope components

2.5.1 Binocular photo tube 30°/23 (100:0/0:100)

The photo port (Fig. 2-8/2) of the binocular tube can be used to mount a reflex camera, a microscope camera or a video camera with the aid of appropriate adapters.

Using the shift knob (or the push-pull rod on other photo tubes), the light can be directed to the eyepieces or to the mounted camera.

- Shift knob (Fig. 2-8/3) in forward position (eye symbol):
100% light to the eyepieces
- Shift knob (Fig. 2-8/3) in back position (camera symbol):
100% light to the camera



NOTE

For polarization microscopy, we recommend using the Pol photo tube with upright image and one eyepiece reticle (graticule).

2.5.2 Binocular ergo tube/ergo photo tube 20°/23 and ergo photo tube 15°/23, each with continuous vertical adjustment

These ergonomic tubes are designed for a field of view of 23 mm. The viewing angle is 20° or 15°.

The ergo photo tubes are equipped with one camera port each (Fig. 2-9/1 and Fig. 2-10/2).

The camera ports can be used to mount a reflex camera, a microscope camera or a video camera with the aid of appropriate adapters.

The camera port can carry a maximum weight of 2.5 kg (camera plus cable). For a fee, the ZEISS service personnel will equip your instrument with a higher maximum load, if needed.

The ergo tubes permit a height adjustment range of 44 mm.

A larger range can be obtained by swiveling the binocular section from the lower to the upper observation position (depending on the interpupillary distance).

- Continuous vertical adjustment by means of the rotary knobs (Fig. 2-9/3 and Fig. 2-10/1)
- The adjustment range of the **ergo photo tube 20°/23** can be read off the vertical scale (Fig. 2-9/4).
- The binocular part of the **ergo photo tube 15°/23** is also continuously horizontally retractable up to 50 mm.

The **ergo photo tube 20°/23** has two switch positions (scale: 100:0/0:100):

- Push-pull rod (Fig. 2-9/2) pushed in: 100% to the eyepieces
- Push-pull rod (Fig. 2-9/2) pulled out: 100% to camera port

The **ergo photo tube 15°/23** (Fig. 2-10) is available only with an upright image and fixed scale (50:50).

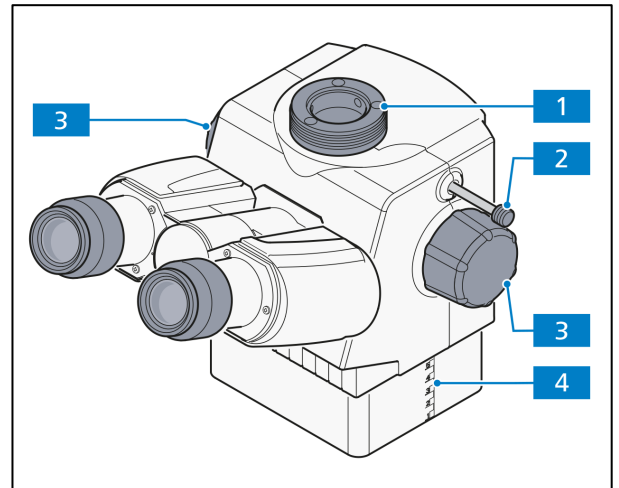

Fig. 2-9 Binocular ergo photo tube 20°/23 with vertical adjustment

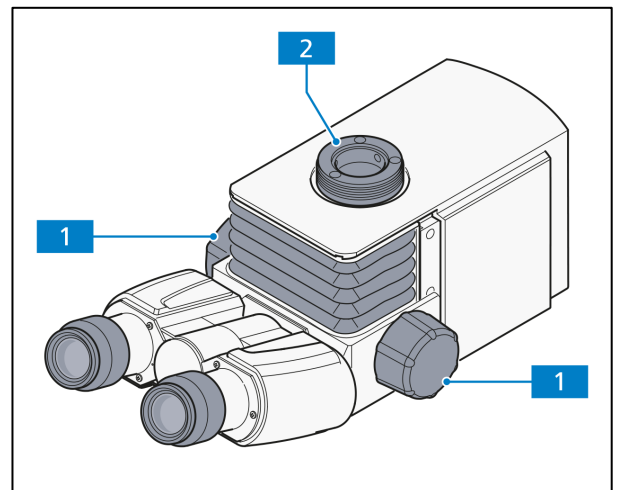

Fig. 2-10 Binocular ergo photo tube 15°/23, telescopic with vertical adjustment

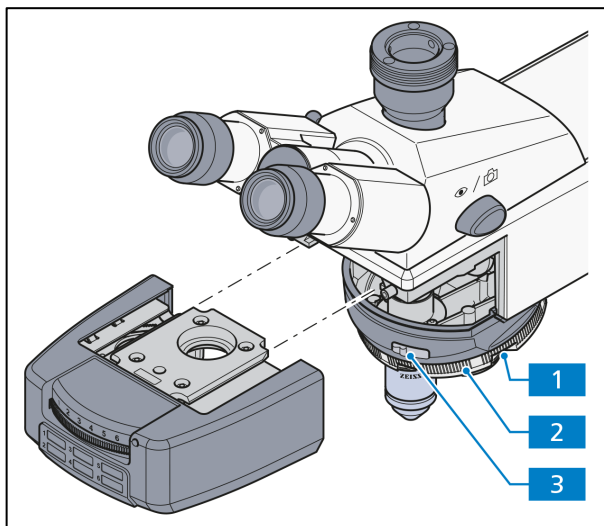

Fig. 2-11 Nosepiece with DIN slot for compensators

2.5.3 Nosepiece with objectives

- Equipped with DIN slot (Fig. 2-11/3) for compensators or fluorescence protection shield
- M27 mounting thread for six objectives
- Equipped with three, six or no DIC positions (Fig. 2-11/1) depending on the configuration
- Turning the knurled wheel of the nosepiece (Fig. 2-11/2) enables you to change the objectives quickly

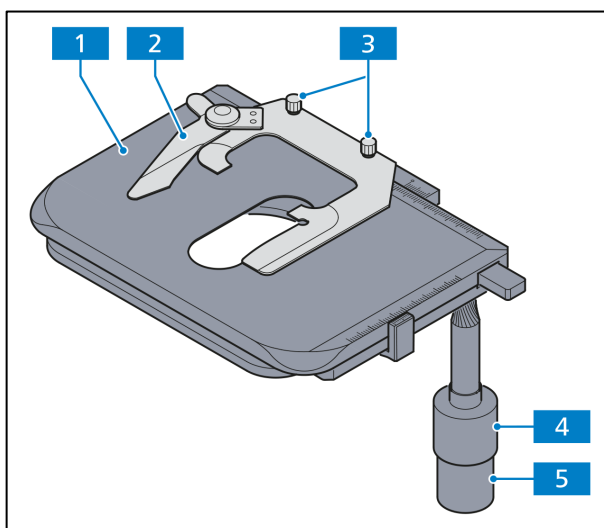

Fig. 2-12 Mechanical stage with specimen holder

2.5.4 Mechanical stage 75x50

- Mechanical stage (Fig. 2-12/1) with specimen holder (Fig. 2-12/2) for holding and positioning the samples
- Two clamping screws (Fig. 2-12/3) for attaching and removing the specimen holder
- Coaxial knurled knobs for X (Fig. 2-12/4) and Y adjustment (Fig. 2-12/5)

2.5.5 Low-power system for 2.5x/4x objectives mounted on the condenser carrier

The low-power system enables full illumination of the field of view when using a low-magnification objective (2.5x-4x) in combination with the condenser 0.9/1.25 H.

It can be centered and remains in the beam path throughout the use of the corresponding objective.

- Swing the low-power system (Fig. 2-13/2) in or out of the beam path using the handle (Fig. 2-13/1). Make sure the module locks in securely.
- Do not use the low-power system with LED illumination for transmitted light.

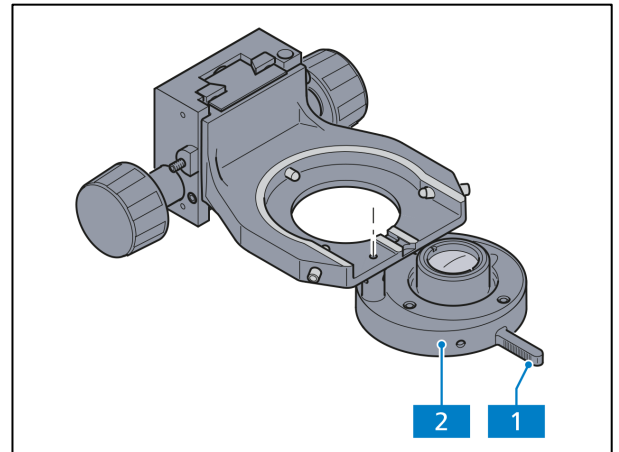

Fig. 2-13 Low-power system mounted on the condenser carrier



ATTENTION

If the condenser carrier with mounted low-power system is moved too far down, the low-power system may collide with the field diaphragm and damage it!

2.5.6 0.9/1.25 BF condenser and 0.9 Pol condenser

The 0.9/1.25 BF condenser (Fig. 2-14/1) with aperture diaphragm (Fig. 2-14/2) can be optionally equipped with a modulator disk (Fig. 2-14/3) for:

- bright-field BF
- dark-field DF
- phase contrast PhC 1, PhC 2, PhC 3
- PlasDIC (optional: To use PlasDIC, the ring diaphragm must be replaced with a 2 mm or 4.5 mm slit diaphragm for PlasDIC)

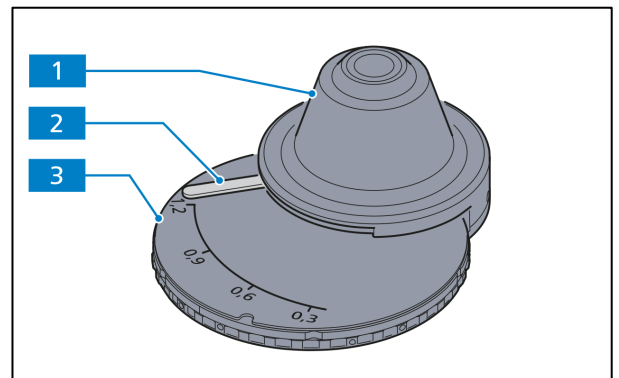

Fig. 2-14 0.9/1.25 BF condenser with modulator disk



ATTENTION

Do not use acetone to clean the lens of the polarizing condensers.

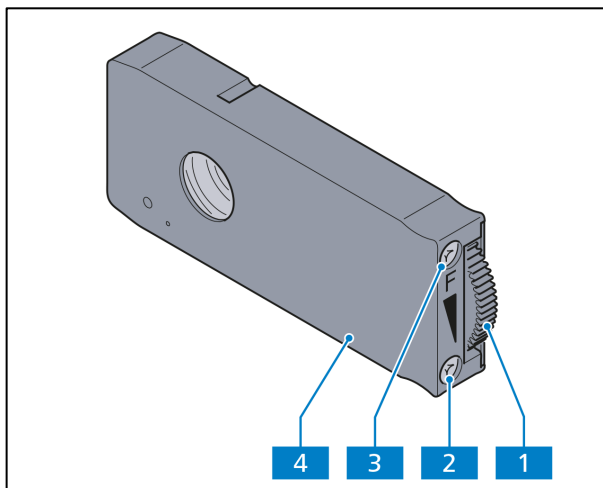

Fig. 2-15 14x40 mm stop slider

2.5.7 14x40 mm stop sliders for aperture and field diaphragms

To adjust the reflected light beam path using the KÖHLER method, one 14x40 mm stop slider (Fig. 2-15/4) mounted in the upper part of the stand is required to function as a field diaphragm (**F**) and another to function as the aperture diaphragm (**A**).

- To open the diaphragm, turn the knurled wheel (Fig. 2-15/1) up.
- To close the diaphragm, turn the knurled wheel (Fig. 2-15/1) down.
- To center the diaphragm to the beam path, adjust the centering screws (Fig. 2-15/2 and 3) with an Allen wrench (AF 3).



NOTE

When applying fluorescent light, you may want to mount an FL attenuator (if not pre-installed) on the level of the aperture diaphragm in order to attenuate the fluorescence radiation.

2.5.8 Reflector turrets with 4 or 6 coded positions

These reflector turrets are equipped with four or six coded push-and-click (P&C) reflector positions.

Turn the knurled wheel to adjust the reflector position. The marking indicates which reflector position is currently in the beam path.

For easy identification we advise that you write down the appropriate data for each position of the mounted reflector modules on the adhesive labels provided with the instrument. Then attach the labels at the appropriate points.

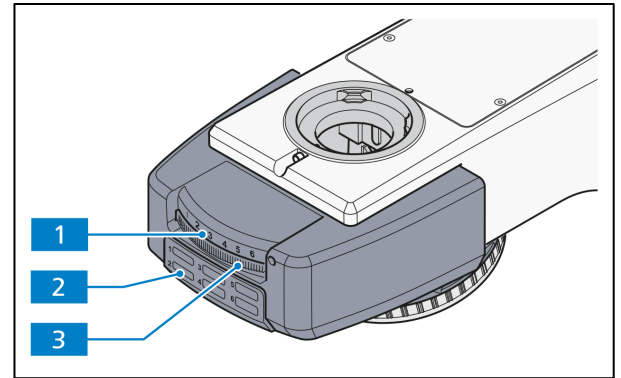

- 1 Display showing the number of the active reflector position
- 2 Spaces for labels with position data
- 3 Knurled wheel with position marks

Fig. 2-16 Reflector turret with 6 coded positions

2.5.9 Reflector slider with 2 coded positions

The reflector slider with two coded positions is equipped with two individually loadable reflector positions for P&C modules which can be slid into the beam path.

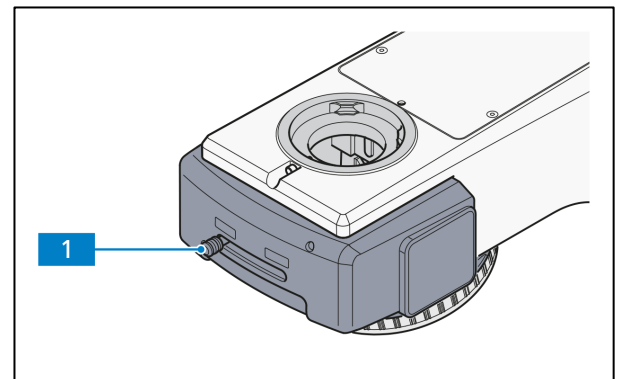

- 1 Slider

Fig. 2-17 Reflector slider 2 coded positions

3 START-UP

The Axioscope microscopes can be installed, modified and started up by the customer himself. On request, the ZEISS Service installs or modifies the microscope for an extra charge.

**NOTE**

Before installing and starting-up the microscope, read the **Notes on instrument safety** (see section 1.1) carefully and thoroughly.

The assembly activities described on the following section are illustrated for the most part by way of examples for one microscope stand type. However, they apply analogously to other microscope stand models. Special features are described separately.

The same activities apply when assembling a microscope stand with an upper stand part and the stand column Vario – special activities for the stand column Vario are described separately.

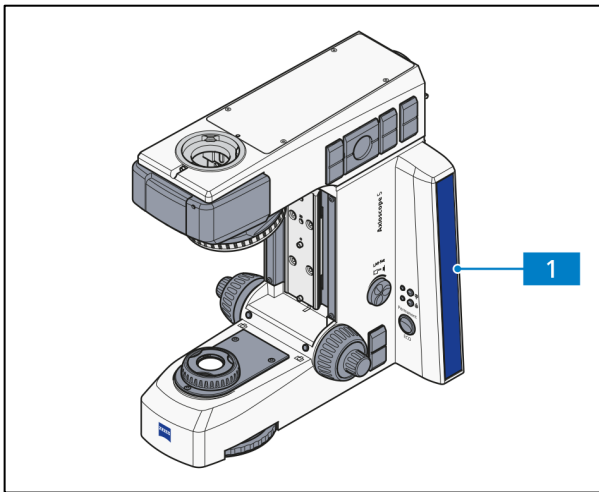

Fig. 3-1 Setting up the microscope

3.1 Mounting standard components

3.1.1 Unpacking and setting up microscope stand

- Remove all components from the packaging and check that all components described on the delivery note are present.
- Set up the microscope stand (Fig. 3-1/1) on a vibration-free, level, hard and non-combustible surface.
- Keep the original packaging for storage or for returning the instrument to the manufacturer, or dispose of it properly.

3.1.2 Mounting the Axioscope 5 Vario material upper stand part on the stand column



ATTENTION

Equipment or parts having a mass of 18 kg or more shall be provided with a means for careful lifting and carrying.

If you are going to use the Axioscope 5 Vario material stand consisting of the Vario upper stand part (Fig. 3-2/2) combined with gear box (Fig. 3-2/3) and the Vario stand column (Fig. 3-2/1), proceed as follows:

- Unpack the Vario upper stand part with gear box and the Vario stand column.
- Position the Vario upper stand part (Fig. 3-2/2) on the mounting plate (Fig. 3-2/5) of the Vario stand column and tighten it with the 6 Allen screws (Fig. 3-2/4).
- In order to adjust the microscope vertically, loosen the release lever (Fig. 3-2/6) on the stand column and adjust the height (according to the size of the specimen) with the hand wheel (Fig. 3-2/7).
- Then tighten the release lever again.

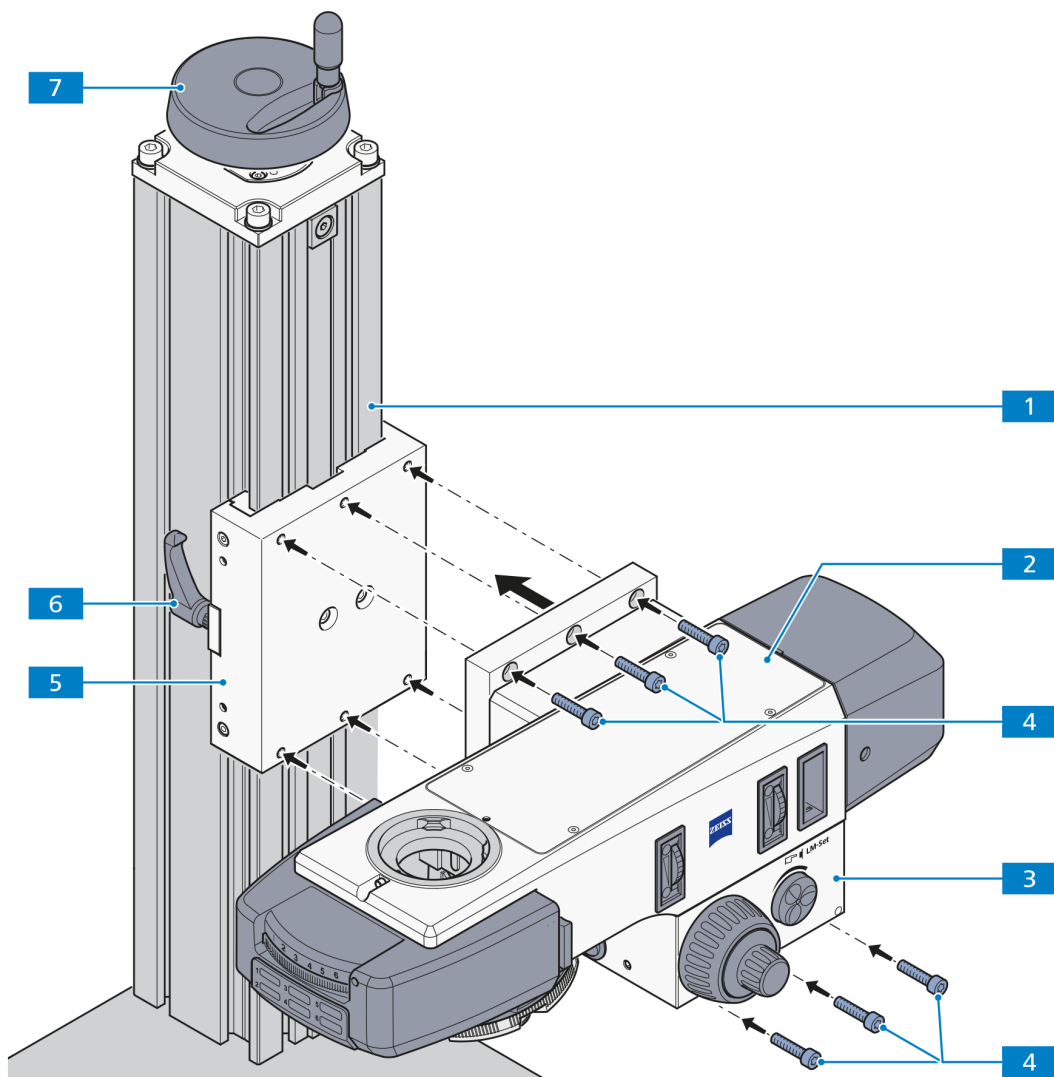

Fig. 3-2 Mounting the Vario upper stand part on the stand column

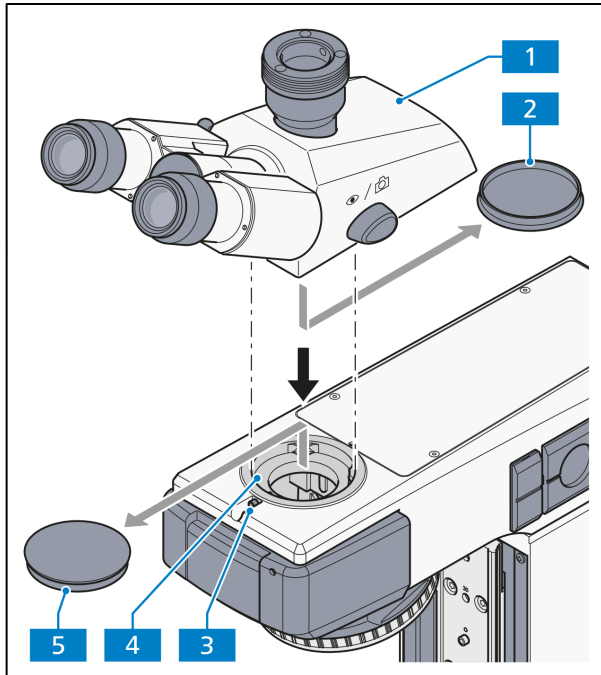

Fig. 3-3 Attaching the binocular tube

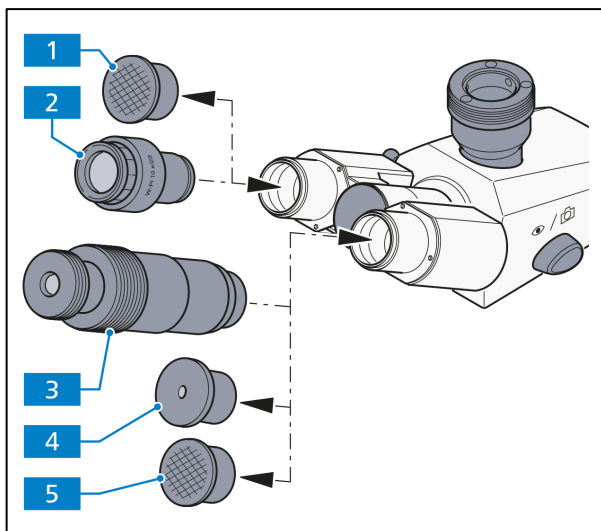

Fig. 3-4 Inserting eyepieces

3.1.3 Mounting the binocular tube/photo tube

- Loosen the screws (Fig. 3-3/3) with the Allen wrench (AF 3).
- Remove the dust cover caps (Fig. 3-3/2 and 5) from the bottom of the tube and the dovetail ring socket on the stand.
- Hold the binocular tube (Fig. 3-3/1) or the binocular photo tube at an angle and insert it into the stand socket with the dovetail ring (Fig. 3-3/4).
- Then push it into a horizontal position. Turn the binocular tube into the desired viewing position and tighten the Allen screws with the Allen wrench.

3.1.4 Inserting eyepieces or auxiliary microscope or pinhole diaphragm

- Remove both dust cover caps (Fig. 3-4/1 and 5) from the binocular tube.
- Remove both eyepieces (Fig. 3-4/2) from the box and insert them into the binocular tube to the stop.
- Instead of an eyepiece you may insert an auxiliary microscope (Fig. 3-4/3) into one of the binocular eyepiece tubes in order to observe aperture, phase and darkfield diaphragms and to center phase and darkfield diaphragms. These diaphragms can be focused with the adjustable eye lens of the auxiliary microscope.
- The auxiliary microscope (Fig. 3-4/3) or the pinhole diaphragm (Fig. 3-4/4) can be used to observe conoscopic images.

Inserting the PL 10x/23 GW focusable Pol eyepieces (444038-9900-000) with reticle into the binocular photo tube with upright image (425520-9100-000)

The PL 10x/23 GW foc. Pol eyepiece contains a reticle firmly glued into it (cannot be changed), which is of defined orientation. When changing the interpupillary distance on the binocular photo tube, the two eyepiece tubes follow this rotary motion synchronously, so that the position of the orientation grooves in the eyepiece tubes remains unchanged.

- Insert the eyepiece into the binocular photo tube, fitting the locating screw (Fig. 3-5/2) into the tube's orientation groove (Fig. 3-5/1).

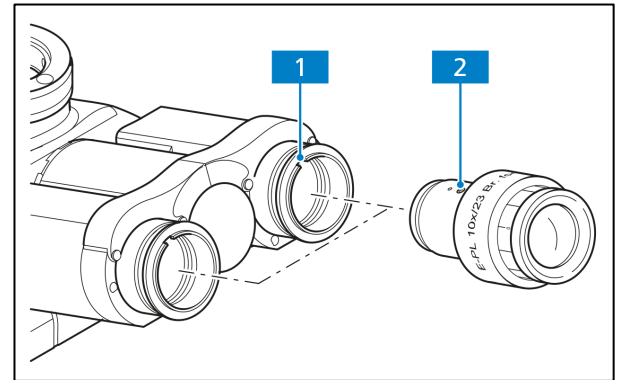

Fig. 3-5 Inserting the E-PL 10x/23 GW foc. Pol eyepieces into the binocular photo tube with upright image

The PL 10x/23 GW foc. Pol eyepiece (444038-9900-000) can be combined with a PL 10x/23 GW foc. eyepiece (444036-9000-000).

Inserting the eyepiece reticle

Eyepiece reticles (Fig. 3-6/5) can be used with eyepieces (Fig. 3-6/3) marked with a red dot (Fig. 3-6/R).

- Unscrew mounting stop (Fig. 3-6/6) from the eyepiece (Fig. 3-6/3).
- Pull locking ring (Fig. 3-6/4) out.
- Insert eyepiece reticle (Fig. 3-6/5) into the mounting stop and fix it with the locking ring.
- Screw mounting stop (Fig. 3-6/6) into the eyepiece (Fig. 3-6/3).

Make sure that the side of the reticle (Fig. 3-6/5) with the line pattern on it is facing the mounting stop in the tube (Fig. 3-6/6) (the line pattern occurs mirror-inverted from the observer's point of view before the insertion). After insertion into the beam path of the microscope it is readable true to side.

The slight image shift caused by the additional path through glass is taken into account on the diopter scale by the fact that the zero point position is indicated not by the white dot (Fig. 3-6/W), but the red dot (Fig. 3-6/R).

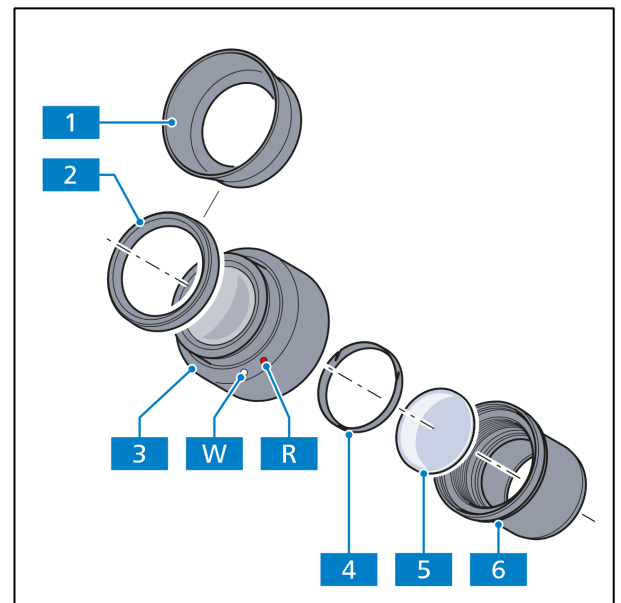

Fig. 3-6 Inserting the eyepiece reticle



NOTE

The eyepiece reticles must be inserted under dust-free conditions. This should be carried out only by ZEISS Service.

Inserting reversible eyecups

The eyepieces have rubber protection rings to avoid scratches on eyeglasses. These may be replaced by reversible eyecups as desired.

- To do this, remove the eyeglass protection rings (Fig. 3-6/2) from the eyepieces and mount the eyecups (Fig. 3-6/1).

Sometimes the eyeglass protection rings are seated very tightly in the eyepiece groove, so you may need a blunt object (wooden stick) to prod them off.

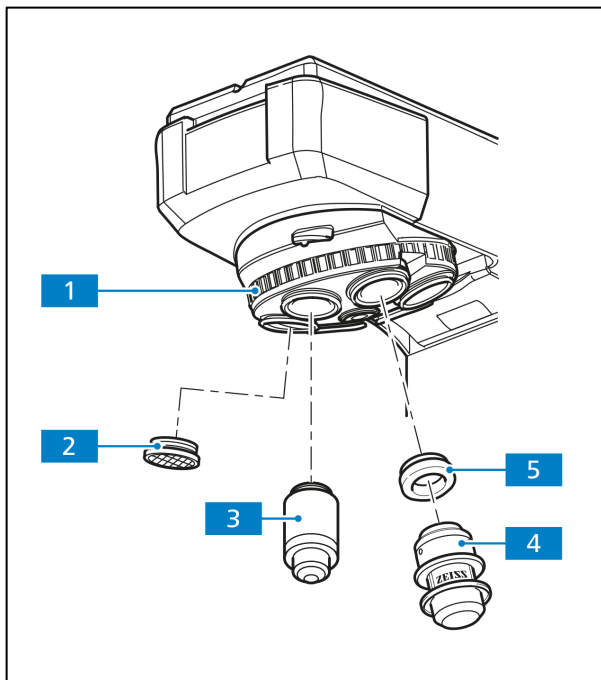

Fig. 3-7 Screwing in objectives

3.1.5 Screwing in objectives

- Lower the mechanical stage with the stage carrier to the bottom stop or lower the stage carrier with the dovetail guide.
- Remove the dust protection caps (Fig. 3-7/2) from the appropriate nosepiece openings.
- Take the objective (Fig. 3-7/3) out of its box and mount it on the nosepiece (Fig. 3-7/1), starting with the smallest magnification factor (set up clockwise).
- Instead of an objective, you may mount an object marker (Fig. 3-7/4) on any position of the nosepiece with the aid of a W0.8/M27 adapter (Fig. 3-7/5). Don't forget to recap the object marker when not in use to prevent it from drying out.



NOTE

Always place dust protection caps over the positions in the nosepiece which are currently not in use.



NOTE

The W0.8/M27 adapter must be used with the W0.8 objective.

3.1.6 Inserting and removing push-and-click (P&C) reflector modules into the reflector insert

To install or uninstall the modules, the reflector insert (reflector turret with 4 or 6 coded positions, reflector slider with 2 coded positions) must be removed from the upper part of the stand.

Inserting a module:

- Remove the reflector insert (Fig. 3-8/1) from the upper part of the stand (section 3.1.7) and put it aside with the top side facing down.
- Insert the module (Fig. 3-8/3) (with the top side facing down) with the aid of its mounting elements on its left and right (Fig. 3-8/4) at a slant from the top into the lower spring clips (Fig. 3-8/2) on the reflector socket.
- Press the module against the upper spring clips of the reflector turret until it engages firmly.

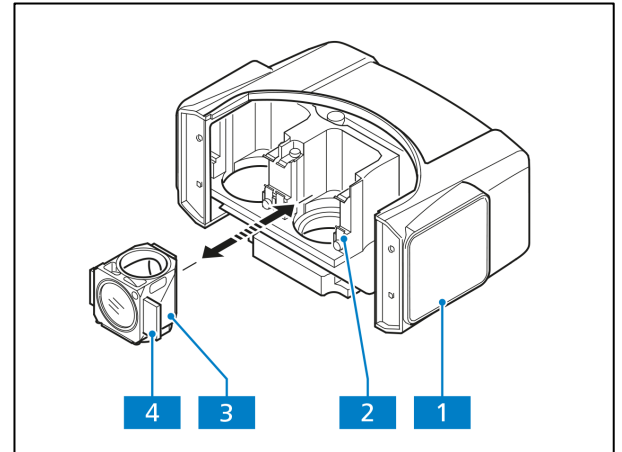

Fig. 3-8 Changing the reflector module in the reflector insert

Removing a module:

- Disengage the module from the upper spring elements by tilting it forward, then lift it off the lower spring elements and remove the module.
- After installing or uninstalling the reflector module, don't forget to replace the reflector insert or the cover cap.

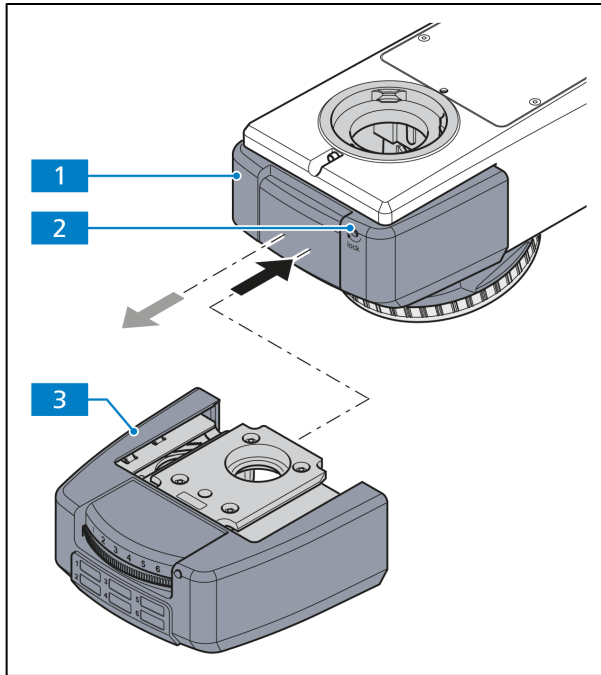

Fig. 3-9 Mounting the reflector insert

3.1.7 Mounting the reflector insert

- First, remove the cover cap (Fig. 3-9/1) by inserting the Allen wrench (AF 3) into the slot (Fig. 3-9/2). Turn the locking screw counterclockwise and pull the cover cap forward.
- Push the reflector insert (Fig. 3-9/3) with the reflector modules P&C (e.g. reflector turret with 6 coded positions) into the upper part of the stand until it stops, hold it and tighten the locking screw again.



NOTE

When the reflector insert is removed, the reflected light path is automatically blocked so that the glare will not affect the operator.

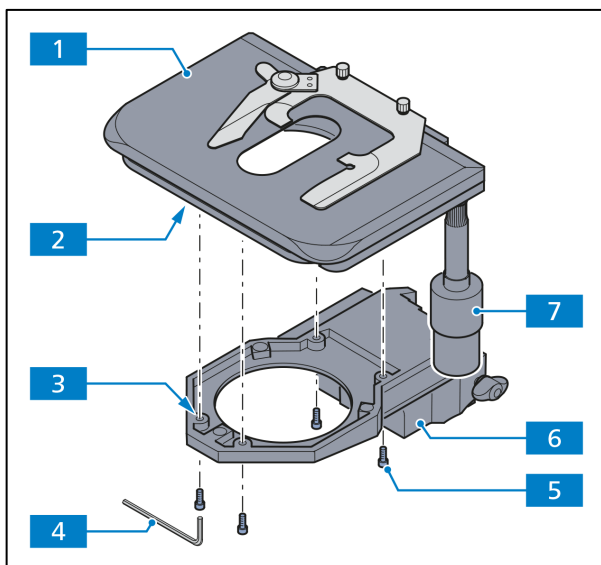

Fig. 3-10 Changing the mechanical stage, 75x50 R

3.1.8 Mounting the mechanical stage

Depending on the type, the mechanical stages can either be stable or they can be rotated and centered. The shift range is 75 mm in the X-direction and 50 mm in the Y-direction.

Stages are available with a coaxial gear knob (Fig. 3-10/7) located on the right or the left side of the stage.

To assemble/disassemble a stage, remove the stage carrier, then reattach the stage carrier with the mounted stage to the stand (see section 3.1.15 on page 59).

(1) Stable mechanical stage, 75x50 R

a) How to remove the stage

- Remove the four mounting screws (Fig. 3-10/5) on the stage carrier (Fig. 3-10/6) using the Allen wrench (AF 3) (Fig. 3-10/4).
- Remove the stage (Fig. 3-10/1) from the stage carrier. This is easier if you turn the stage and its

carrier over.

b) How to mount the stage

- Fit the stage (Fig. 3-10/1) onto the stage carrier (Fig. 3-10/6) so that the threaded holes in the bottom of the stage (Fig. 3-10/2) are on top of the corresponding holes in the stage carrier (Fig. 3-10/3).
- Insert the four mounting screws (Fig. 3-10/5) from below through the holes in the stage carrier and screw them into the bottom of the stage.
- Tighten the screws.

	NOTE
<p>After long hours of use, the stage guide may be loose and the stage travel range may be decreased. However, this is not a malfunction and can be corrected easily as described below.</p>	

c) How to adjust the X- and Y-axis knob tension

- In the X-direction, hold the specimen holder and move the stage guide to the left and right until it hits the stoppers (Fig. 3-11/1, 2).
- In Y-direction, hold the upper stage and move it to the front and rear until it hits the stoppers.

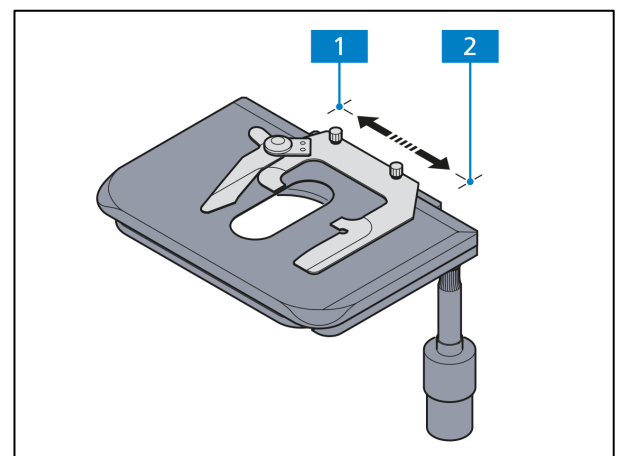
**Fig. 3-11** Adjusting the X- and Y-axis knob tension**(2) Rotatable mechanical stage 75x50/240° R**

	NOTE
<p>Rotatable stages can be used only with the stage carrier for rotatable stages (430710-9011-000).</p>	

a) How to remove the stage

- Loosen the screw cap (Fig. 3-12/2) of the spring pin with approx. 3 turns.
- Press the stage forward against the spring pin (Fig. 3-12/1), lift the back side off the stage carrier (Fig. 3-12/3) and remove it by lifting it upward.
- Tighten the screw cap (Fig. 3-12/2).

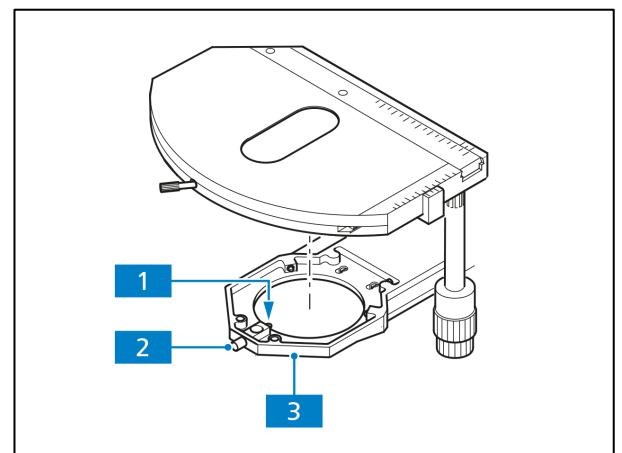
**Fig. 3-12** Changing the rotatable mechanical stage

b) How to mount the stage

- Loosen the screw caps (Fig. 3-12/2) of the spring box with approx. 3 turns.
- Put the stage with the dovetail ring notch onto the spring pin (Fig. 3-12/1).
- Press the stage forward against the spring pin and lower its back side into the stage carrier (Fig. 3-12/3).
- Tighten the screw caps (Fig. 3-12/2).

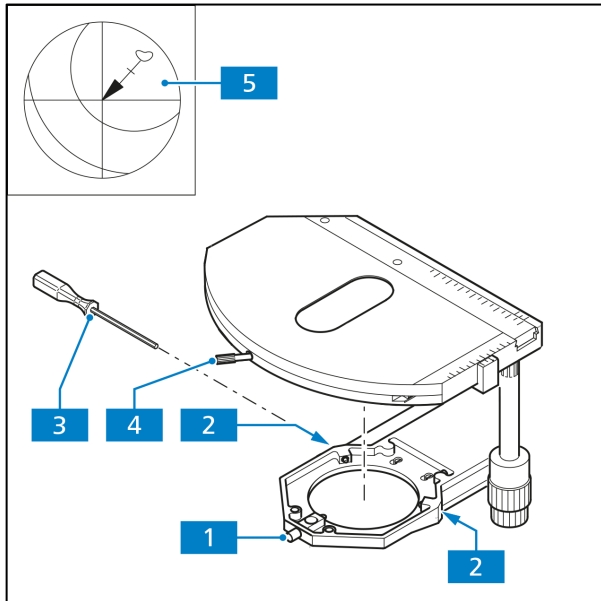

Fig. 3-13 Centering the rotatable mechanical stage

c) How to center the stage

When using objectives with a high magnification, only one selected objective can be centered exactly at a time.

All stages are delivered pre-centered, i.e. when the stage is turned, the detail of the specimen in the focus remains in the center of the image. If the detail shifts out of the center when the stage is turned (Fig. 3-13/5), then it becomes necessary to re-center the stage.

- Loosen the clamping screws of the stage (Fig. 3-13/4) and the screw cap of the stage carriers (Fig. 3-13/1).
 - Determine the maximal shift of the specimen (Fig. 3-13/5, arrow point) to the cross line in the eyepiece by turning the stage.
 - Shift the specimen detail towards the center of the cross line by turning each the two centering screws on the stage carrier (Fig. 3-13/2) with an Allen wrench (AF 1.5) (Fig. 3-13/3) half the length of the arrow. Repeat the procedure if the specimen detail shifts out of the center again when turning the stage.
- After finishing the centering procedure tighten the screw caps (Fig. 3-13/1) again.

The stage can be turned by 240° within a shifting range of $y \leq 27$ mm. No turning of the stage is possible outside of this range.

(3) Adjusting the drive length on the ergonomic drives

An axial shift of the coaxial knurled knobs by a **maximum of 15 mm** can extend the drive length of the **X** and **Y** shift on the mechanical stages with ergonomic drives.

(4) Removing and mounting the additional sleeves

Both coaxial knurled knobs for the stages are equipped with additional sleeves for an even more sensitive adjustment of the specimen position. These sleeves can be removed in those cases when it is important to shift the specimen more quickly.

- Loosen both clamping screws (Fig. 3-14/4) on the lower additional sleeve (Fig. 3-14/3) and remove them by pulling them down. Then loosen both clamping screws (Fig. 3-14/2) on the upper additional sleeves (Fig. 3-14/1) and remove them by pulling them down as well.
- Re-mount the additional sleeves on the coaxial knurled knobs by following the above steps in reverse order. Tighten the clamping screws when you are done.

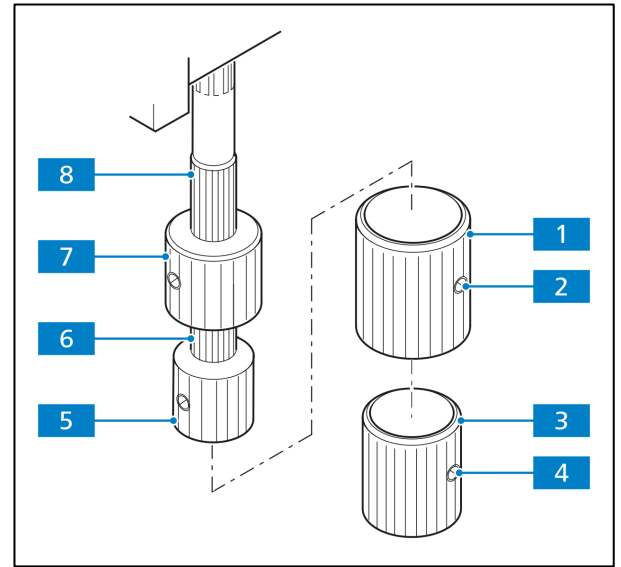

Fig. 3-14 Adjusting ergonomic drive

(5) Adjusting the friction (smoothness of operation) on both coaxial knurled knobs of the ergonomic drives

The smoothness of ergonomic operation is factory pre-set to a medium level. The operator can change the friction as follows:

a) How to adjust the X-direction

- Remove the additional sleeves (Fig. 3-14/1 and 3) from the coaxial knurled knobs by loosening the clamping screws.
- Shift the X-coaxial knurled knob (Fig. 3-14/5) downward and the Y-coaxial knurled knob (Fig. 3-14/7) upward.
- Hold the X-coaxial knurled knob (Fig. 3-14/5) and turn the light-colored knurled ring above it (Fig. 3-14/6) to the right (increased smoothness) or left (decreased smoothness) until you reach the desired level.

b) How to adjust the Y-direction

- Hold the Y-coaxial knurled knob (Fig. 3-14/7) and turn the light-colored knurled sleeve above it (Fig. 3-14/8) to the right (increased smoothness) or the left (decreased smoothness) until you reach the desired level.
- Replace the additional sleeves and tighten the clamping screws.



NOTE

You can increase the service life of the stage by cleaning the specimen holder regularly and avoiding particulates from the mechanical guide system of the X-motion.

3.1.9 Mechanical stages with friction adjustment

The drive length and friction for the X- and Y-adjustment can be adjusted individually on the standard mechanical stage (432035-9002-000) and the mechanical stage 432035-9070-000.

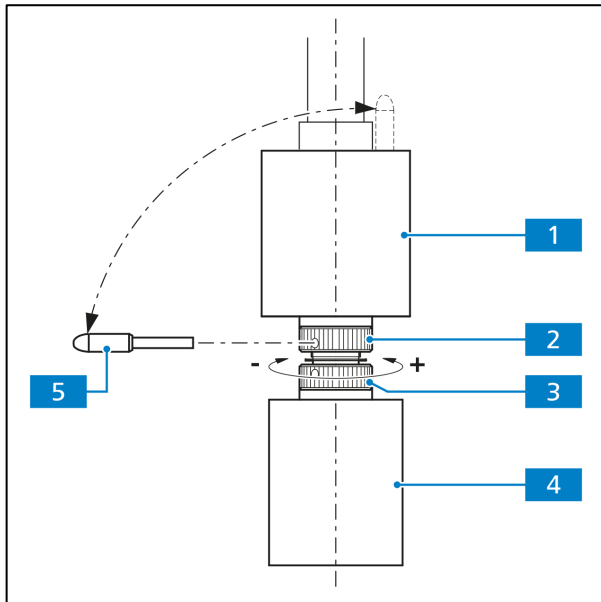

Fig. 3-15 Adjusting the frictional momentum

(1) Adjusting the drive length on the stage drive

The drive length of the X- and Y-drive can be adjusted by an axial shift of the coaxial knurled knob (Fig. 3-15/4 and 1) within a range of approx. 15 mm.

(2) Adjusting the frictional torque of the coaxial knurled knobs for the X-/Y-adjustment of the mechanical stage

The frictional torque of the coaxial knurled knobs is factory-preset to a medium level which can be changed as follows if necessary:

a) X-drive

- Slide the coaxial knurled knob for the X-adjustment (Fig. 3-15/4) all the way down.
- Take the enclosed adjustment pin (Fig. 3-15/5) out of the coaxial knurled knob for the Y-adjustment (Fig. 3-15/1) and stick it into one of the holes on the lower hole nut (Fig. 3-15/3).

- Hold the coaxial knurled knob for the X-adjustment (Fig. 3-15/4) and turn the hole nut with the adjustment pin clockwise (lower frictional torque: **-**) or counterclockwise (higher frictional torque: **+**) until you reach the desired level of friction (see Fig. 3-15).
- The adjustment should not be more than **one** rotation.

b) Y-drive

- Slide the coaxial knurled knob for the Y-adjustment (Fig. 3-15/1) all the way up.
- Stick the enclosed adjustment pin (Fig. 3-15/5) into the hole on the upper hole nut (Fig. 3-15/2).
- Hold the coaxial knurled knob for the Y-adjustment (Fig. 3-15/1) and turn the hole nut with the adjustment pin clockwise (lower frictional torque: **-**) or counterclockwise (higher frictional torque: **+**) until you reach the desired level of friction.
- The adjustment should not be more than **one** rotation.
- Replace the adjustment pin in the coaxial knurled knob for the Y-adjustment (Fig. 3-15/1).

3.1.10 Attaching the Pol rotary stage

Two rotary stage models are available. The mounting procedure is the same for each model.

3.1.10.1 Removing the Pol rotary stage

- Loosen the screw cap (Fig. 3-16/8) of spring pin with about 3 turns.
- Push the Pol rotary stage (Fig. 3-16/5) to the front against the spring-loaded pin (Fig. 3-16/9), lift it off the stage carrier (Fig. 3-16/7) at the back and remove it upwards.
- Retighten the screw cap (Fig. 3-16/8).

3.1.10.2 Attaching the Pol rotary stage

- If necessary, loosen the screw cap (Fig. 3-16/8) of the spring pin with about 3 turns.
- Place the Pol rotary stage with the groove of the dovetail (stage bottom) on the spring-loaded pin (Fig. 3-16/9).
- Attach the rotary stage (432035-9191-000) with the clamping screw (Fig. 3-16/10) pointing to the front right.
- Push the Pol rotary stage to the front against the spring-loaded pin and lower it at the back into the stage carrier (Fig. 3-16/7), then release it.
- Retighten the screw cap (Fig. 3-16/8).

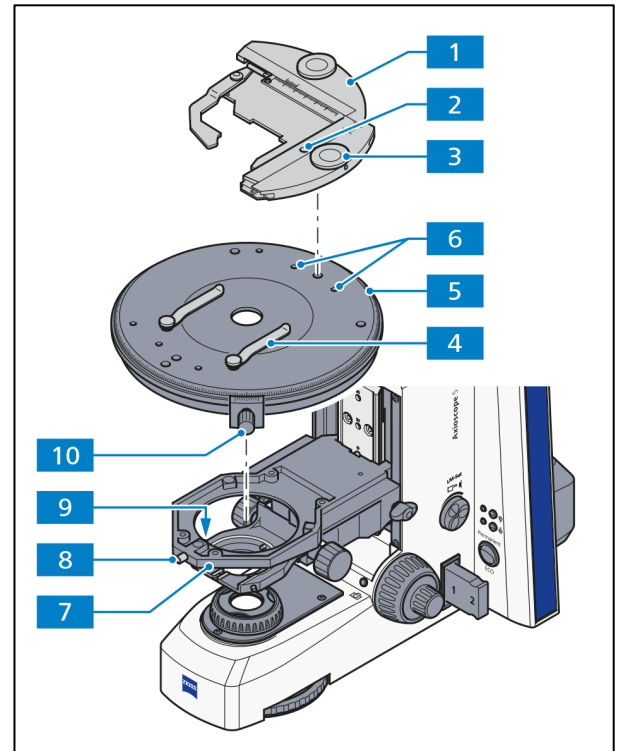

Fig. 3-16 Changing the Pol rotary stage with click stop, attachable Pol object guide and stage clips



NOTE

When you are using the rotary stage (432035-9131-000), the click stop must point to the front.

3.1.10.3 Removing the attachable Pol object guide and mounting stage clips

- Turn the control wheel (Fig. 3-16/3) of the Pol object guide (Fig. 3-16/1) until the clamping screw becomes visible in the mounting hole (Fig. 3-16/2).
- Use the Allen wrench to loosen the clamping screw. Remove the Pol object guide Pol upwards.
- Insert the stage clips (Fig. 3-16/4) into the holes on the stage provided for this purpose.
- Attach the Pol object guide (453560-0000-000) for the large rotary stage (453550-0000-000) in the same way.
- Attach the D Pol specimen holder for transmitted light specimens or the A Pol specimen holder for reflected light specimens and mount the balance weight on the stage.

3.1.10.4 Removing the stage clips and attaching the Pol attachable object guide

- Remove stage clips (Fig. 3-16/4) from rotary stage Pol.
- Insert the Pol object guide (Fig. 3-16/1), introducing the two cylindrical pins on its underside into the respective holes (Fig. 3-16/6) and tighten the clamping screw firmly (Fig. 3-16/2). Where required, turn the control first to make the clamping screw accessible.

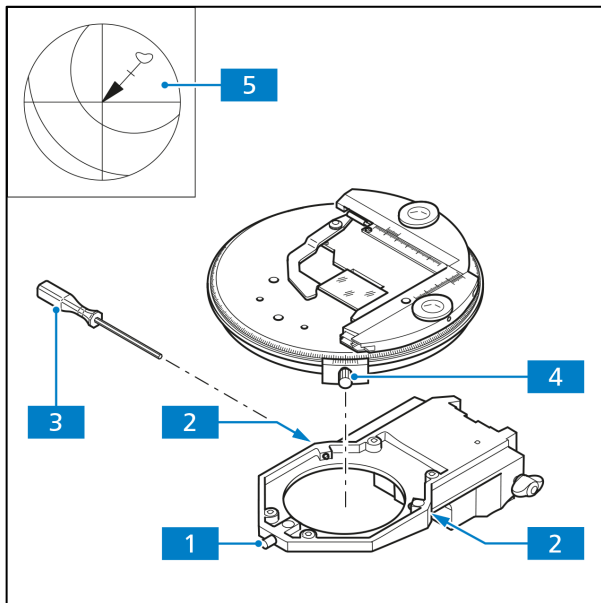

Fig. 3-17 Centering the Pol rotary stage

3.1.10.5 Centering the Pol rotary stage

With high-power objectives, stage centricity can be exact only for one selected objective.

All stages are factory-pre-centered, i.e. when rotating the stage the specimen feature set to the center of the field of view will remain in the center. If the specimen feature moves off the center of the field of view (Fig. 3-17/5) while you are rotating the stage, the stage should be re-centered as follows.

- Before centering the stage, you must adjust the KÖHLER illumination on the microscope (see section 4.2.1).
- For stage centering, use a contrast-rich specimen and an eyepiece with reticle.
- Loosen the stage click-stop (Fig. 3-17/4) or clamp (on the Pol rotary stage with clamping device) and unscrew the stage carrier cap (Fig. 3-17/1).
- Rotate the stage to determine the position of maximum offset of the specimen feature (Fig. 3-17/5, origin of arrow) from the center of the eyepiece reticle.
- Turn the two centering screws on the stage carrier (Fig. 3-17/2) with one Allen wrench (AF 1.5) (Fig. 3-17/3) each to move the specimen feature by half the arrow length towards the reticle center. Rotate the stage again to check if the specimen feature moves off. Repeat the centering procedure, if necessary.
- After centering, retighten the screw cap (Fig. 3-17/1).

3.1.10.6 Centering objectives of polarizing microscope stands

The nosepiece with 5-positions HF/DF/Pol and 1-position HF/DF/DIC is equipped with five centerable objective mounts (without DIC slots) as well as one objective mount with DIC slot (non-centerable). Accordingly, all objectives can be centered relative to the rotary stage.

Stage centering is necessary to ensure that a specimen feature located in the center of the field of view does not move out while you are rotating the stage. Centering all objectives ensures that the specimen feature remains in the center of the field of view even when the objective is changed.

- Before centering the stage, you must adjust the KÖHLER illumination on the microscope (see section 4.2.1).
- For stage centering, use a contrast-rich specimen and an eyepiece with reticle.
- First, turn the nosepiece to swing the non-centerable objective mount (mount with DIC slot) into the light path. Center the rotary stage for the non-centerable objective mount as described under 3.1.10.5.
- Turn the nosepiece to move a centerable objective mount into the light path.
- Rotate the stage to determine the position of maximum offset of the specimen feature (Fig. 3-18/3, origin of arrow) from the center of the eyepiece reticle.
- Turn the two centering screws on the nosepiece (Fig. 3-18/1) using one AF 1.5 Allen wrench (Fig. 3-18/2) each to move the specimen feature by half the arrow length towards the reticle center. Rotate the stage again to check whether the specimen feature moves off. Repeat the centering procedure, if necessary.
- Center the other four objectives in the same manner.

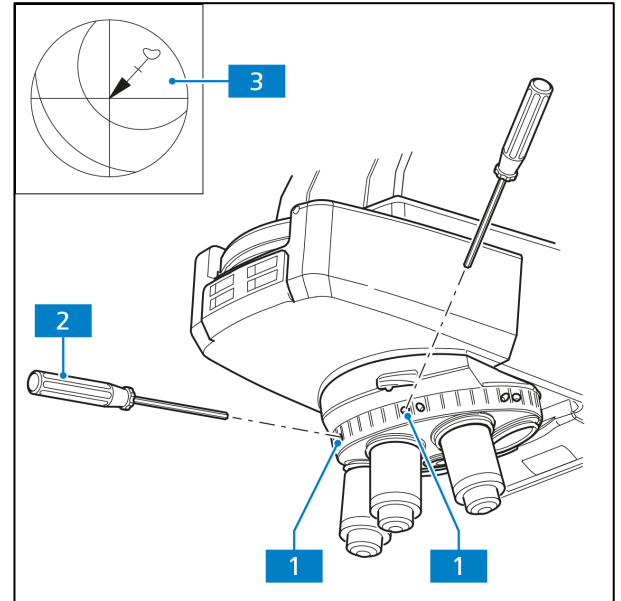

Fig. 3-18 Centering objectives



NOTE

To preserve this centered state it is imperative to change the objectives only by turning the nosepiece by its knurled ring, without touching the objectives.

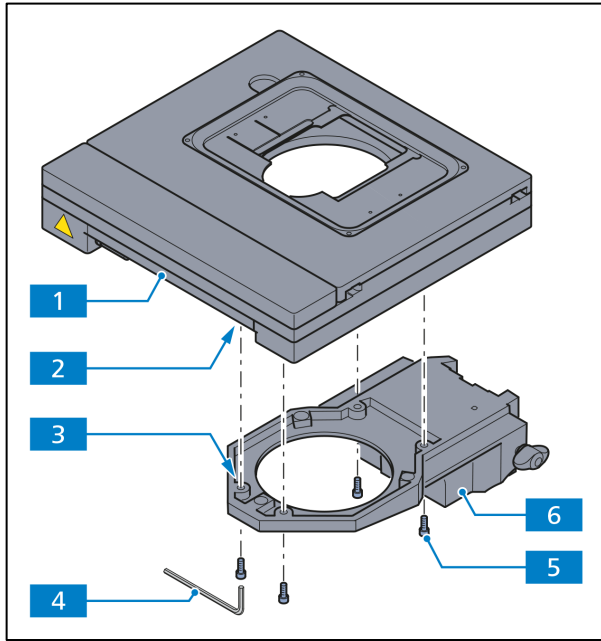

Fig. 3-19 Changing the motorized mechanical stage

3.1.11 Mounting/removing the 80x60 motorized mechanical stage on the Axioscope 7 motorized material stand

The motorized stage can only be mounted on/removed from the stand as an entire unit with the stage carrier (see section 3.1.15 on page 59).

How to remove the stage

- Unplug the power cable connector (Fig. 3-20/1) of the stage from the socket on the stand (Fig. 3-20/2).
- Turn the stage (Fig. 3-19/1) and stage carrier (Fig. 3-19/6) upside down and remove the four mounting screws (Fig. 3-19/5) with the Allen wrench (AF 3) (Fig. 3-19/4).
- Carefully remove the stage from the carrier.

How to mount the stage

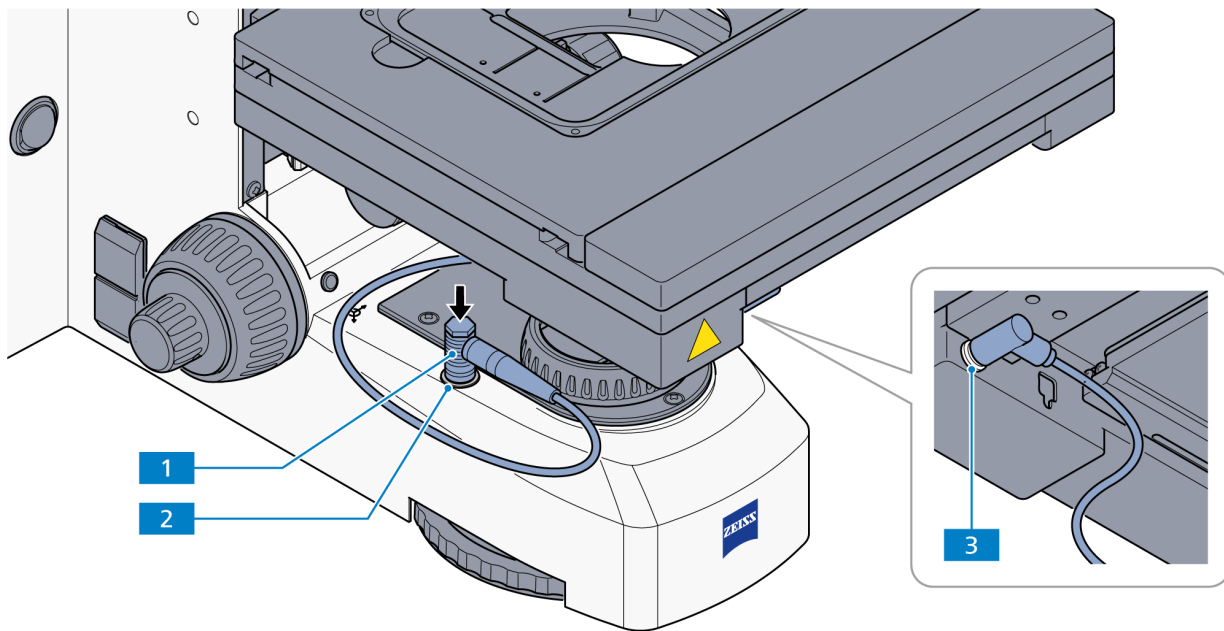

Fig. 3-20 Plugging in the power cable of the motorized mechanical stage

- Turn stage (Fig. 3-19/1) and stage carrier (Fig. 3-19/6) upside down carefully and match the threaded holes in the bottom of the stage (Fig. 3-19/2) to the corresponding holes in the carrier (Fig. 3-19/3).
- Insert the four mounting screws (Fig. 3-19/5) into the holes.
- Align the stage in XY-direction and tighten the screws with the Allen wrench (AF 3).
- Plug the power cable connectors (Fig. 3-20/1) into the sockets on the stage (Fig. 3-20/3) and on the stand (Fig. 3-20/2).

3.1.12 Mounting the condenser carrier

- Adjust the guide of the condenser carrier (Fig. 3-21/3) using the coaxial knurled knob (Fig. 3-21/2) until both screws (Fig. 3-21/4) become accessible.
- Mount the condenser carrier on the stage carrier (Fig. 3-21/1), slide it firmly and straight up to the upper stop and tighten both screws.

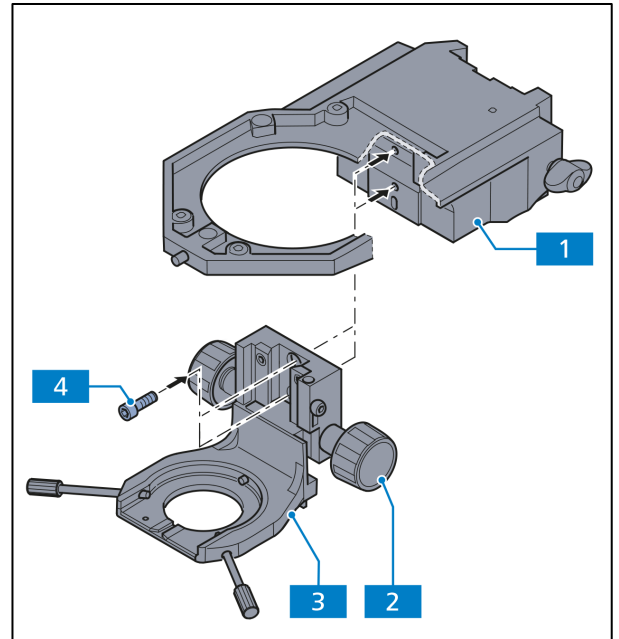

Fig. 3-21 Mounting the condenser carrier

3.1.13 Mounting the condenser

- Slide the stage carrier with the focusing drive to the upper stop.
- Unscrew both centering screws (Fig. 3-22/5) on the condenser carrier until you cannot see the end parts anymore.
- Unscrew the clamping screw (Fig. 3-22/9) on the right side of the condenser carrier until the maximum vertical adjusting range is usable.
- Slide the condenser carrier (Fig. 3-22/3) with the knurled knob for vertical adjustment (Fig. 3-22/2) all the way down.
- Open the front lens (if switchable) on the condenser using the lever (Fig. 3-22/7).
- Insert the condenser (Fig. 3-22/8) between the condenser carrier (Fig. 3-22/3) and the stage carrier (Fig. 3-22/1). Adjust the guide pin on the bottom of the condenser in the direction of the slot (Fig. 3-22/6).
- Push the condenser with the dovetail ring against the spring box (Fig. 3-22/4) of the condenser carrier until the condenser can be placed on the condenser carrier horizontally.
- Release the condenser and its pin screw will slide into the front slot (Fig. 3-22/6).
- Tighten the centering screws until they engage in the condenser's dovetail ring.
- Unscrew the clamping screw (Fig. 3-22/9) without clamping the vertical drive.

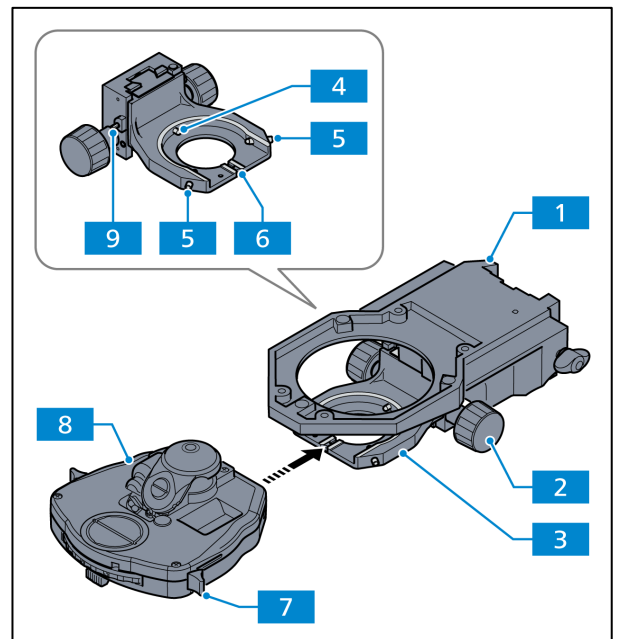





Fig. 3-22 Mounting the condenser

	NOTE
	Follow the same procedure when mounting other condensers.

	NOTE
	If an additional component, e.g. a polarizer, has been mounted beneath the condenser carrier, the stage carrier should be removed.

	NOTE
	If the Abbe condenser is used in combination with a rotary stage, ensure that the position of the condenser head is centered as exactly as possible relative to the stage opening.

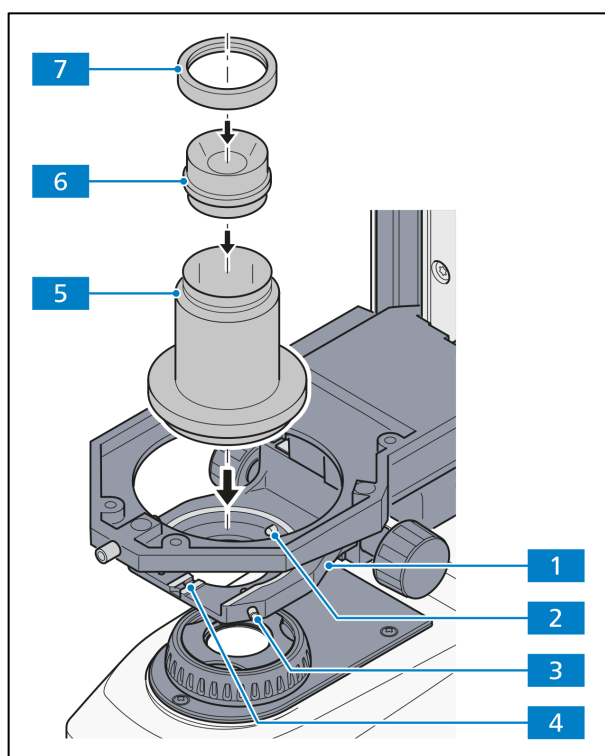



Fig. 3-23 Mounting the darkfield condenser

3.1.14 Mounting the darkfield condenser

	NOTE
	The condenser holder Z for darkfield is required to place darkfield condensers in the condenser carrier.

- Insert the darkfield condenser (Fig. 3-23/6) in the condenser holder Z (Fig. 3-23/5) and screw on the fastening ring (Fig. 3-23/7).
- Push the condenser holder Z (Fig. 3-23/5) against the spring box (Fig. 3-23/2) into the condenser carrier (Fig. 3-23/1).
- Tighten both centering screws (Fig. 3-23/3) on the condenser carrier (Fig. 3-23/1) until they grip the dovetail ring and hold the condenser holder Z (Fig. 3-23/5) in place.

3.1.15 Mounting the stage carrier

- Screw the shoulder screw (Fig. 3-24/3) into the appropriate opening:
 - Opening with mark **0** (Fig. 3-24/3):
No sample space extension is mounted.
 - Opening with mark **30** (Fig. 3-24/2):
The sample space extension for **30 mm** is mounted.
 - Opening with mark **60** (Fig. 3-24/1):
The sample space extension for **60 mm** (430030-9111-000) is mounted.
- Insert the stage carrier (Fig. 3-24/5) at a slight angle (beneath the shoulder screw) from the left into the guide, then push it in straight and tighten the wing screw (Fig. 3-24/4) slightly.
- Push the stage carrier along the guide upward until it engages in the shoulder screw. Tighten the wing screw.
- Check to ensure that the guide is accurately positioned.

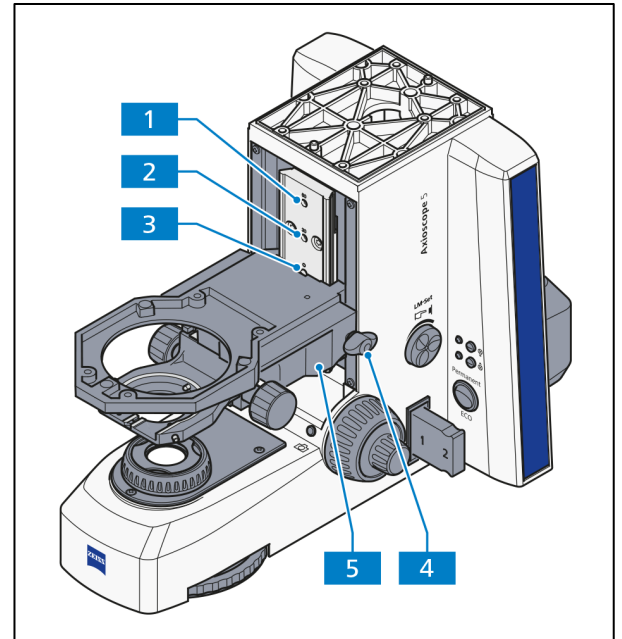

Fig. 3-24 Mounting the stage carrier

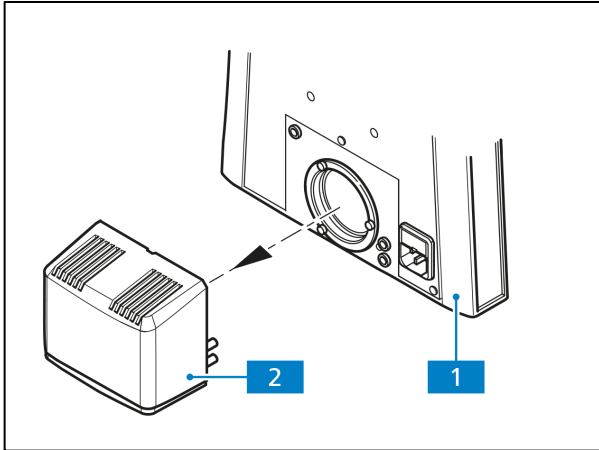

Fig. 3-25 Removing the HAL 50 halogen illuminator from the stand

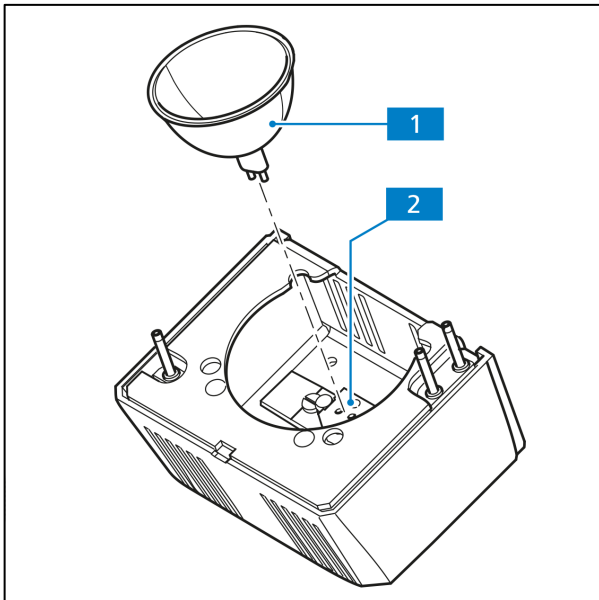

Fig. 3-26 Inserting halogen lamp 12 V, 50 W

3.1.16 Changing the 12 V, 50 W halogen lamp of the HAL 50 halogen illuminator

- Switch off the microscope and disconnect it from the power supply. Wait at least 15 minutes for the halogen lamp to cool down.
- Remove the HAL 50 halogen illuminator (Fig. 3-25/2) from the back of the stand (Fig. 3-25/1) and put it down with the open side facing up.
- Remove the used 12 V, 50 W halogen lamp (if necessary) by pulling it out of the cap (Fig. 3-26/2) in an upward motion.
- Push the new lamp (Fig. 3-26/1) with its two cap pins gently and carefully into the lamp cap (Fig. 3-26/2). Be careful not to touch the protective glass of the lamp. To avoid bending its cap pins or damaging the lamp holder, the lamp must not be tilted.
- Place the HAL 50 halogen illuminator with the connecting pins into the back side of the microscope and push until the lamp engages securely.
- Reconnect the microscope to the power supply.

3.1.17 Mounting the illuminator TL LED10 CRI90/RL LED10 CRI90

- Using the Allen wrench (AF 3) (Fig. 3-27/7), loosen the clamping screw (Fig. 3-27/6) of the TL illumination connector (Fig. 3-27/1) or the RL illumination connector (Fig. 3-27/2) at the lower back of the stand.
- Connect the illuminator's power plug (Fig. 3-27/4) to the socket (Fig. 3-27/3) on the lower part of the stand (or the upper part of the stand).
- Match the illuminator's (Fig. 3-33/5) dovetail ring to the connection piece on the stand. Ensure that the illumination cable is not being pinched or clamped.
- Tighten the clamping screw (Fig. 3-33/6 or 2) with the Allen wrench (AF 3).

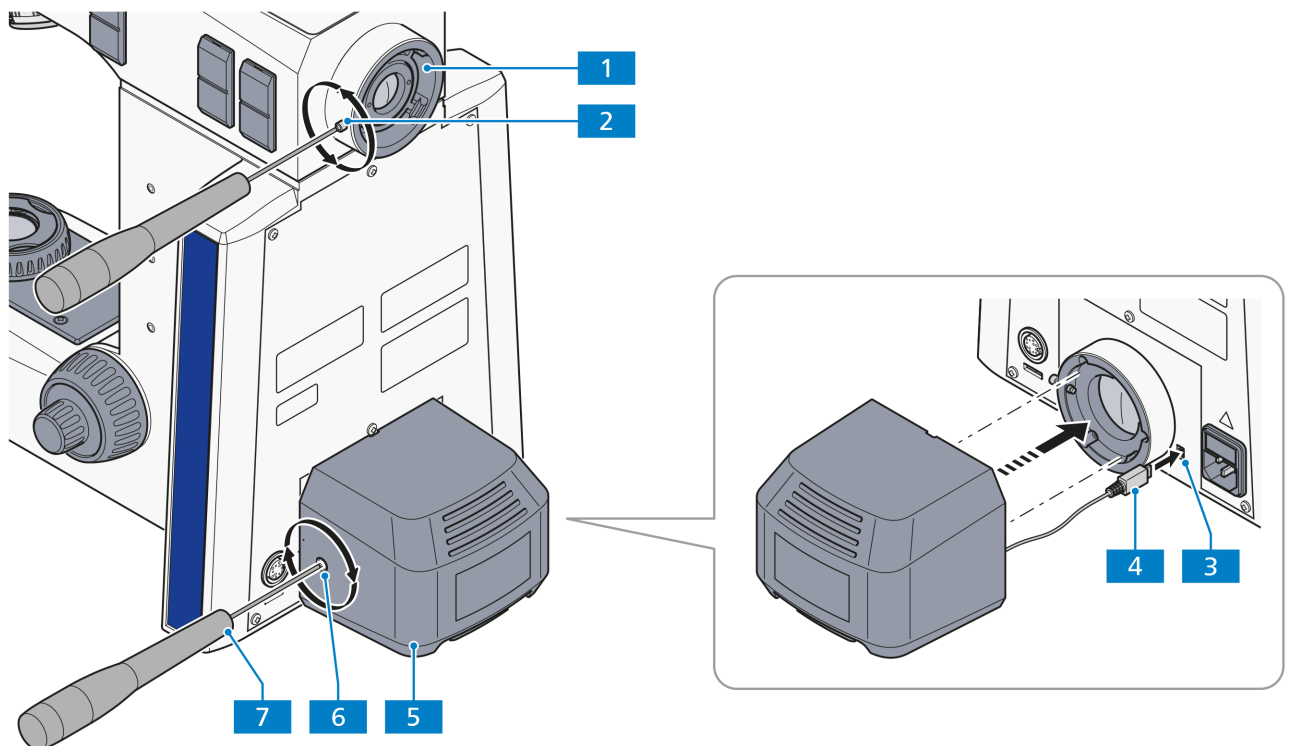

Fig. 3-27 Mounting the TL LED10 illuminator or RL LED10 illuminator

3.1.18 Mounting the Axioscope base plate on the stand

**NOTE**

When using the HAL or HBO illuminators, a base plate for Axioscope (000000-2202-526) is mandatory.

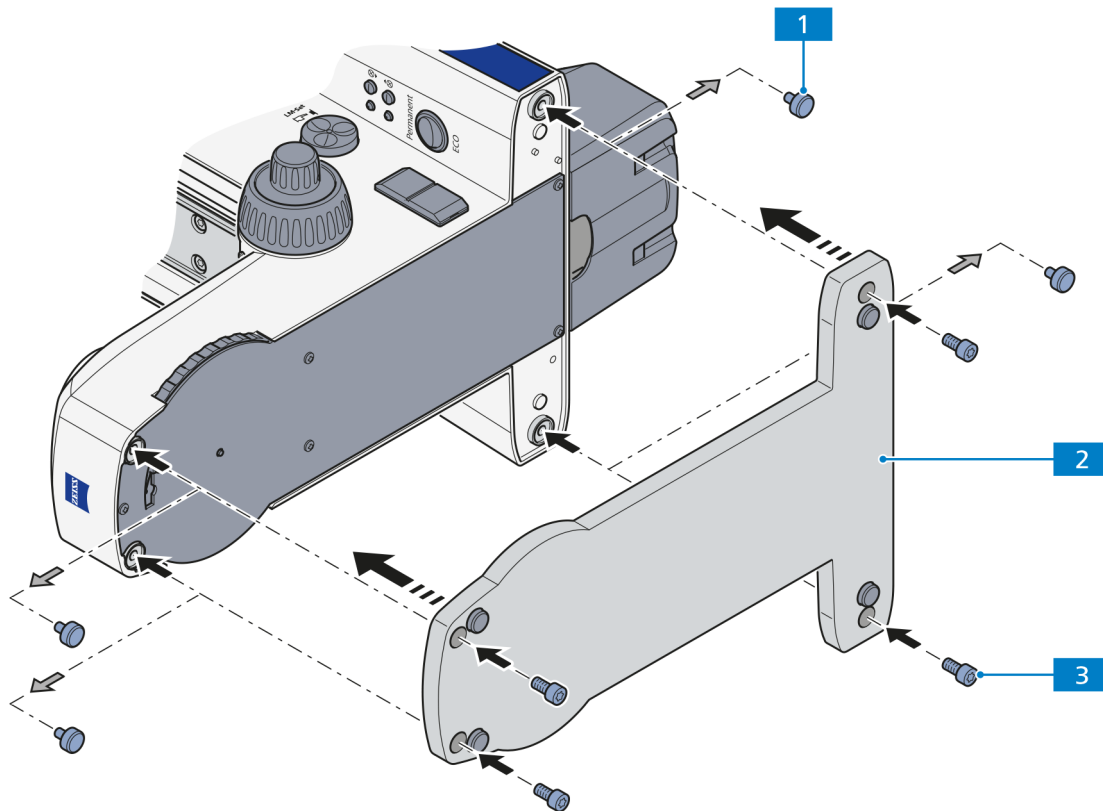

Fig. 3-28 Mounting the base plate

- Remove the four rubber feet (Fig. 3-28/1) from the bottom of the stand.
- Align the base plate (Fig. 3-28/2) with the stand and insert a hexagonal socket screw (M6) (Fig. 3-28/3) into each of the four holes in the base plate.
- Tighten the screws (M6) with an Allen wrench to fix the base plate to the stand.

3.1.19 Mounting and adjusting the HAL 100 halogen illuminator

The HAL 100 halogen illuminator may serve as a light source for transmitted light and reflected light procedures (except fluorescence light) as long as either the lower or upper part of the stand is equipped with the appropriate connection piece. When mounting the halogen illuminator, no difference is made between reflected light and transmitted light procedures.

3.1.19.1 Mounting the HAL 100

	ATTENTION
<p>Before switching on the halogen illuminator, remove the tools (Fig. 3-31/7) included in the illuminator case to prevent them from being damaged by heat.</p>	

- With the Allen wrench (AF 3) loosen the clamping screw of the respective illumination connector (lower for TL (Fig. 3-29/8), upper for RL (Fig. 3-29/1)) on the back of the stand.
- Insert the lamp case (Fig. 3-29/7) with the dovetail ring into the connector (Fig. 3-29/2 or Fig. 3-29/3). Now fixate it by tightening the clamping screw (Fig. 3-29/1 or Fig. 3-29/8) with the Allen wrench.

	NOTE
<p>Due to the lack of ground clearance it is important to avoid tilting the illuminator when inserting it into the lower stand part. Check for straight and correct fit.</p>	

- Connect the 3-pin lamp plug (Fig. 3-29/6) to the respective socket on the back of the external power supply unit (suited for two lamps) (Fig. 3-29/5): plug the TL illuminator into the lower **TL** socket, plug the RL illuminator into the upper **RL** socket.
- Connect the cable (Fig. 3-29/4) for illumination intensity control (see section 3.3.2).

	NOTE
<p>If this cable is connected to the stand, the illumination intensity of the HAL 100 in use can be varied by rotating the Intensity/LM knob (Fig. 2-2/6).</p> <p>If this cable is not connected to the stand, the illumination intensity of the HAL 100 in use can be varied by rotating the adjusting wheel of the external power supply unit.</p> <p>To switch between the illuminators for reflected and for transmitted light, flip the toggle switch of the power supply unit to TL for transmitted light or to RL for reflected light (see section 3.3).</p>	

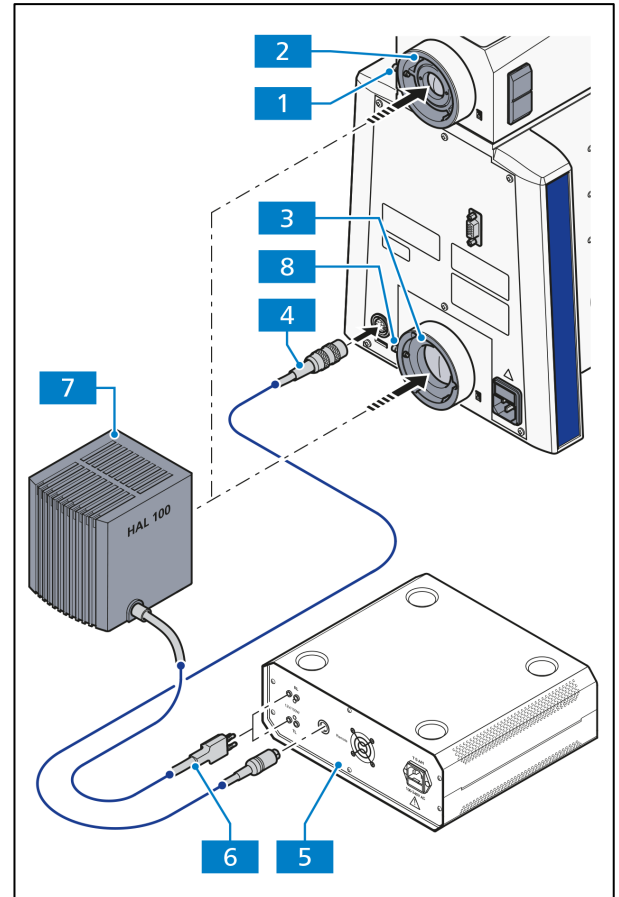

Fig. 3-29 Mounting the HAL 100

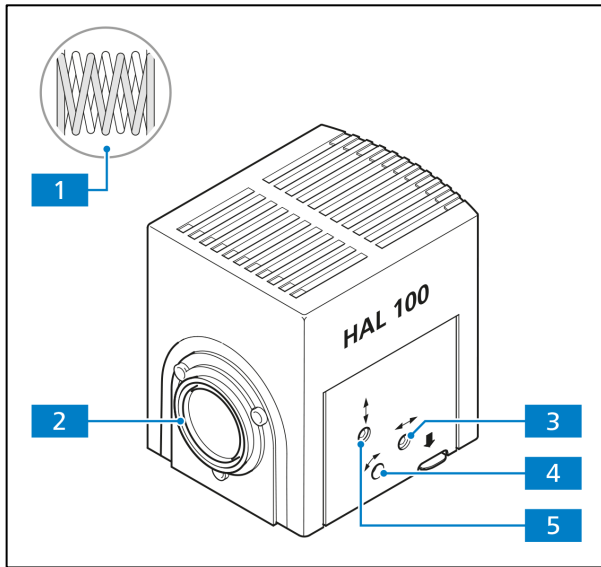

Fig. 3-30 Adjusting the HAL 100

3.1.19.2 Adjusting the HAL 100

Coarse setting

- After loosening the clamping screw (Fig. 3-29/1 or Fig. 3-29/9), remove the ready-to-operate halogen illuminator (Fig. 3-30/2) from the microscope stand.
- Switch on the external power supply unit of the HAL 100 (see section 3.3.3).
- Direct the light beam towards a projecting surface (wall) which is at least 3 m away.

	CAUTION
Never look directly into the light-emitting aperture of the illuminator!	

- Adjust the adjustment screw (Fig. 3-30/3) using an Allen wrench (AF 3) until both images of the lamp filament appear as sharp as possible on the projection surface.

- Adjust the adjustment screws (Fig. 3-30/4 and 5) so that the lamp filament of one image exactly fills the gaps of the reflected image (Fig. 3-30/1).

Fine setting

- Mount the illuminator on the microscope stand again and tighten the clamping screw to lock it.
- If applicable, remove the filter from the beam path.
- Focus the objective $\leq 40\times$ on the flat specular surface of a sample and go to a free area of the specimen.
- Remove the eyepiece and center the lamp filament and its reflection in the eye pupil image with the adjustment screws (Fig. 3-30/4 and 5).
- Optimize the even illumination of the pupil image with the adjustment screws (Fig. 3-30/3).
- If applicable, replace the filter in the beam path.

3.1.19.3 Changing the halogen lamp 12 V, 100 W

	CAUTION
	Hot surface! Danger of burns!
	Always let the illuminator case cool off for at least 15 min before touching it!

	NOTE
	It is not necessary to remove the illuminator case from the stand when replacing the halogen lamp.

- Switch off the external power supply unit of the HAL 100 (see section 3.3.3). Disconnect the 3-pin plug from the HAL 100.
- Press the release button (Fig. 3-31/3) of the halogen illuminator HAL 100 (Fig. 3-31/1). Pull the lamp carrier (Fig. 3-31/2) out completely and put it aside.
- Press both spring levers downwards (Fig. 3-31/5) and pull out the old halogen lamp (Fig. 3-31/6) in an upward motion.
- Press both spring levers downwards, insert the new lamp into the lamp cap (Fig. 3-31/4) and release the spring levers. Use only the included special tools (Fig. 3-31/7) when holding/grabbing the halogen lamp. Traces of skin grease on the halogen lamp can impair its life span.
- Press the spring levers down again briefly. The lamp is now centered.
- Replace the lamp carrier and slide it in until it engages fully.
- Re-connect the 3-pin plug of HAL 100.

	ATTENTION
	Before switching on the halogen illuminator, remove the tools (Fig. 3-31/7) included in the illuminator case to prevent them from being damaged by heat. The replacement lamp (Fig. 3-31/8) may remain in the illuminator case.

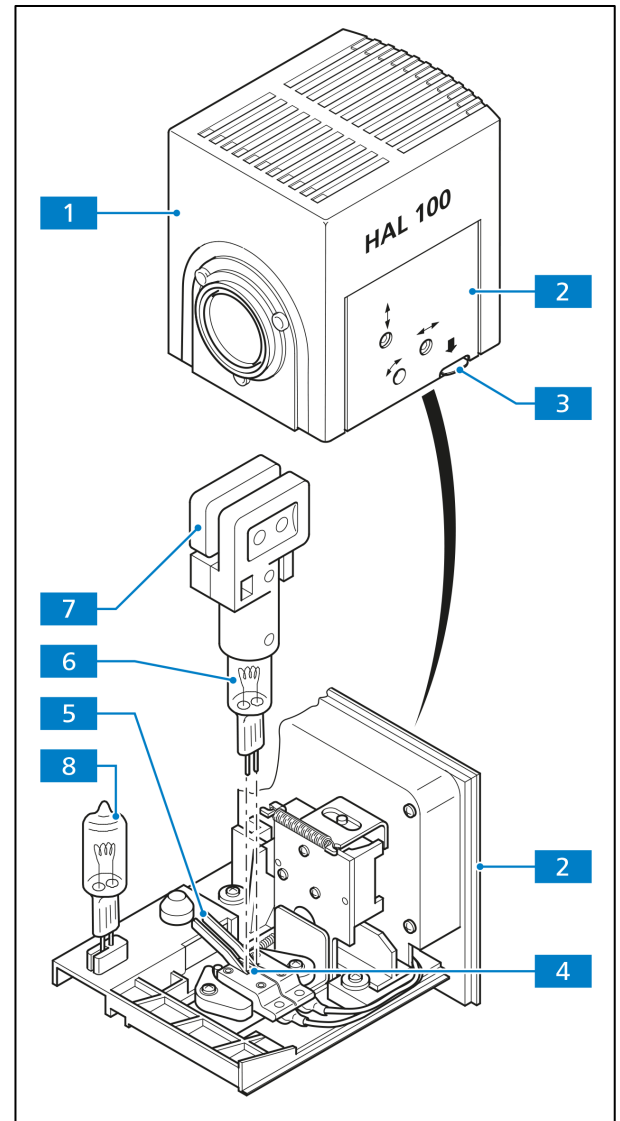

Fig. 3-31 Changing the HAL 100

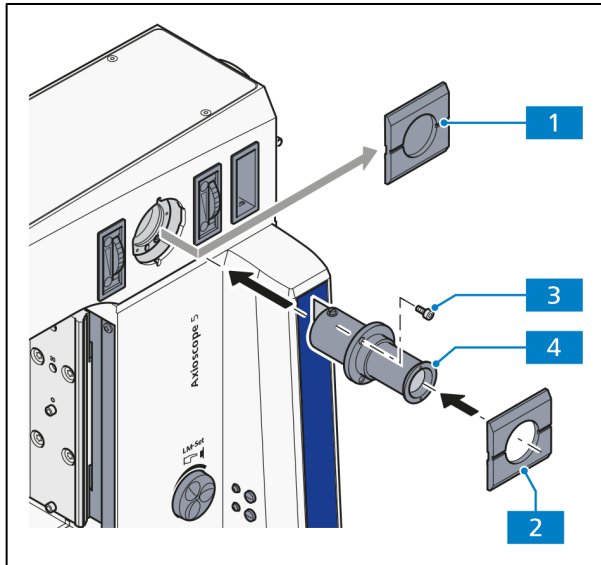

Fig. 3-32 Inserting the adjustment tool

3.1.20 Inserting the adjustment tool of HBO 100 into the stand Bio-TL/RL

- Remove the cover (Fig. 3-32/1) from the mounting aperture of the adjustment tool.
- Insert the adjustment tool (Fig. 3-32/4) and tighten the three included screws (Fig. 3-32/3).
- Attach the cap to the opening (Fig. 3-32/2). Make sure it locks.
- Slide in the movable connecting piece of the adjustment tool.



NOTE

The adjustment tool is used to adjust the HBO 100 illuminator; see section 3.1.21.3.

3.1.21 Mounting and adjusting the HBO 100 illuminator

3.1.21.1 Inserting the HBO 103 W/2 mercury vapor short arc lamp

For safety reasons, the HBO 100 illuminator and the HBO 103 W/2 mercury vapor short arc lamp are packed separately.



NOTE

Please read the manual included with the unit before inserting or replacing the HBO 103 W/2 lamp.

- Insert the HBO 103 W/2 lamp into the illuminator as described in the accompanying manual.



ATTENTION

Please use an FL attenuator (if it is not installed continuously) to modify the transmission. Gray filters are not resistant enough on the long run.

3.1.21.2 Mounting the HBO 100 illuminator

- Remove the cover from the reflected light connection piece (Fig. 3-33/1).
- Insert the illuminator case (Fig. 3-33/3) with the dovetail ring in the reflected light connection piece (Fig. 3-33/1) on the back of the unit. Tighten the clamping screw (Fig. 3-33/2) with the Allen wrench (AF 3).
- Connect the HBO 100 lamp cable to the power supply unit (Fig. 3-34/1). Secure with retaining ring.
- First, plug the cord into the outlet (Fig. 3-34/2) of the power supply unit, then insert the power plug into the electrical outlet.

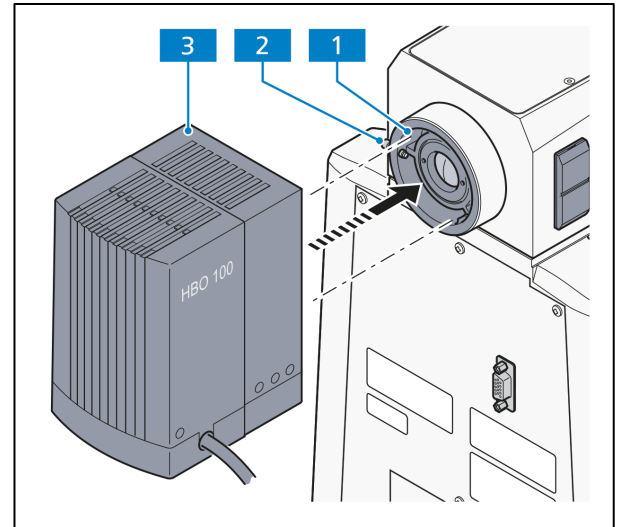

Fig. 3-33 Mounting the HBO 100

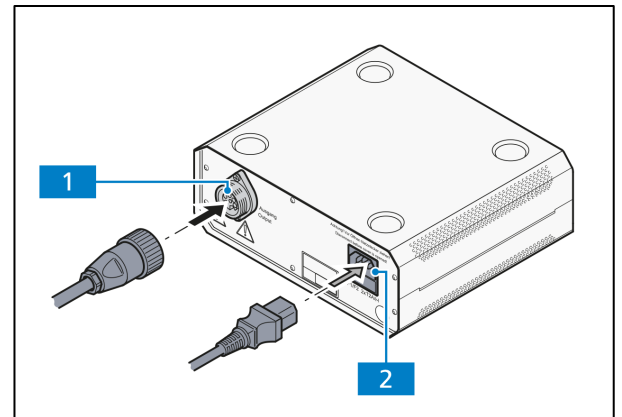

Fig. 3-34 Power supply unit for HBO 100

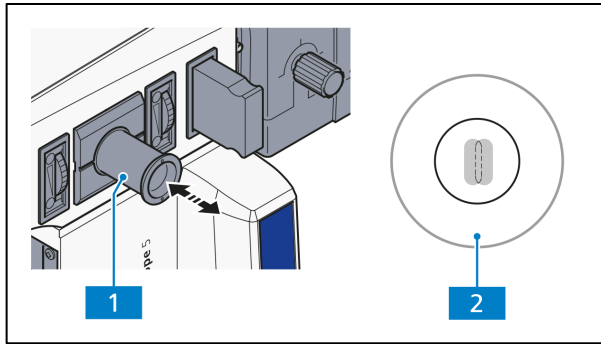

Fig. 3-35 Adjustment tool

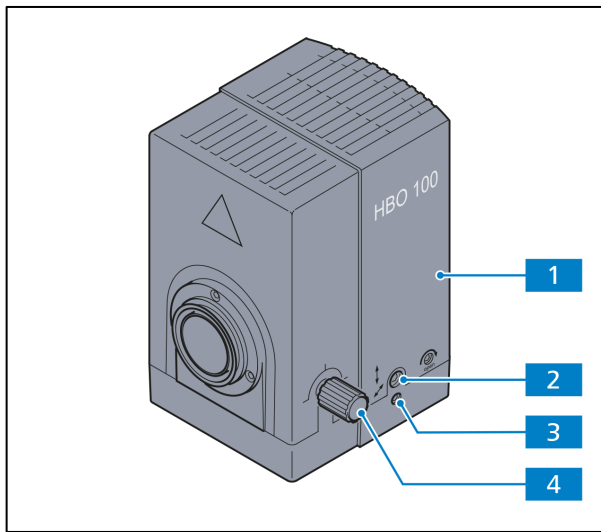

Fig. 3-36 Adjusting the HBO 100

3.1.21.3 Adjusting the HBO 100 illuminator

The HBO 100 illuminator is available in two versions (manual and automatic adjustment).

The self-adjusting HBO 100 (423011-9901-000) adjusts automatically when the power supply unit is turned on.

Follow the instructions below to adjust the HBO 100 illuminator manually (423010-0000-000).



NOTE

If the FL attenuator is in the reflected light beam path, make sure that it is set to 100% transmission.

- Turn on the HBO 100 illuminator (Fig. 3-36/1) on the power supply unit for the HBO 100 (Fig. 3-55/1) and wait until it reaches its operational temperature.
- Pull the adjustment tool (Fig. 3-35/1) out of the microscope stand. The lighter colored focal point of the lamp HBO 103 W/2 and its slightly darker reflection become visible in the black glass window of the adjustment tool.
- Use the knurled button (Fig. 3-36/4) for collector adjustment to focus the brighter focal point.
- Use the adjustment screws (Fig. 3-36/2 and 3) to focus the darker focal point (reflection) as you would for the focal point image (Fig. 3-35/2) in the inscribed adjustment circle.



NOTE

The two focal points of the HBO 103 W/2 lamp should be close to each other in the adjustment circle of the adjustment tool!

- Replace the adjustment tool in its original position.

3.1.22 Mounting the Colibri 3 illumination system and changing the LED modules

3.1.22.1 Mounting the Colibri 3 illumination system on the upper part of the Axioscope stand



CAUTION

Before removing the Colibri 3 from the microscope stand, please make sure the main power is switched off. Never look directly into the light-emitting aperture of the lamp.

- With the Allen wrench (AF 3) (Fig. 3-37/6) loosen the clamping screw (Fig. 3-37/5) of the RL illumination connector on the upper back of the stand.
- Align the illuminator's (Fig. 3-37/1) dovetail ring with the connection piece (Fig. 3-37/2) at the stand.
- Tighten the clamping screw (Fig. 3-37/5) with the Allen wrench (AF 3).
- Connect the illuminator plug (Fig. 3-37/4) to the stand socket (Fig. 3-37/3).
- Tighten the fixing screws on the plug.

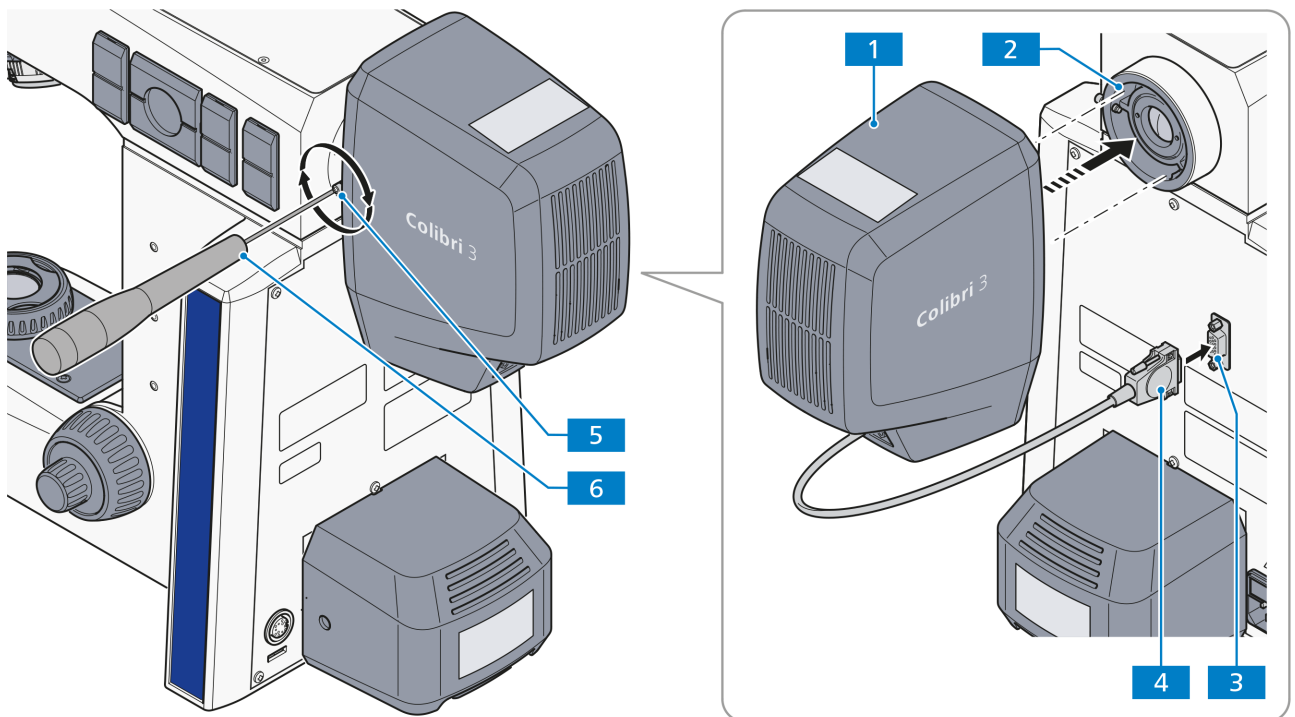

Fig. 3-37 Mounting the illumination system Colibri 3

3.1.22.2 Changing the LED modules in the Colibri 3 illumination system

How to change an LED module, i.e. the LED module for LED slot 1 (Fig. 3-38/①):

- Remove the Colibri 3 from the stand: Follow the instructions of section 3.1.22.1 in reverse order.
- Loosen the four captive clamping screws (Fig. 3-38/5) on the front side with an Allen wrench (AF3).
- Remove the back cover (Fig. 3-38/7).
- Disconnect the LED module power cable connector (Fig. 3-38/1.1) from the PCBA (Fig. 3-38/1.6).
- Loosen the knurled knob (Fig. 3-38/1.3) by hand and remove the old LED module (Fig. 3-38/1.4).
- Select the right LED module with matched LED-specific labels (Fig. 3-38/1.2 and 1.5) and insert it in the correct slot (Fig. 3-38/①).



NOTE

One label on the LED slot (Fig. 3-38/1.5) indicates the wavelength range for this position; the other label on the LED module housing (Fig. 3-38/1.2) indicates the wavelength of the LED module. See the table below as well.

- Tighten the knurled knob (Fig. 3-38/1.3) again.
- Push the LED module power cable connector (Fig. 3-38/1.1) back to the PCBA (Fig. 3-38/1.6).
- If required, replace the LED modules of LED slots 2, 3 and 4 (Fig. 3-38/②, ③ and ④) in the same way.
- Mount the back cover (Fig. 3-38/7) and fasten the four anti-loss clamping screws (Fig. 3-38/5) with an Allen wrench (AF3).
- Re-mount the Colibri 3 on the stand again (see section 3.1.22.1).

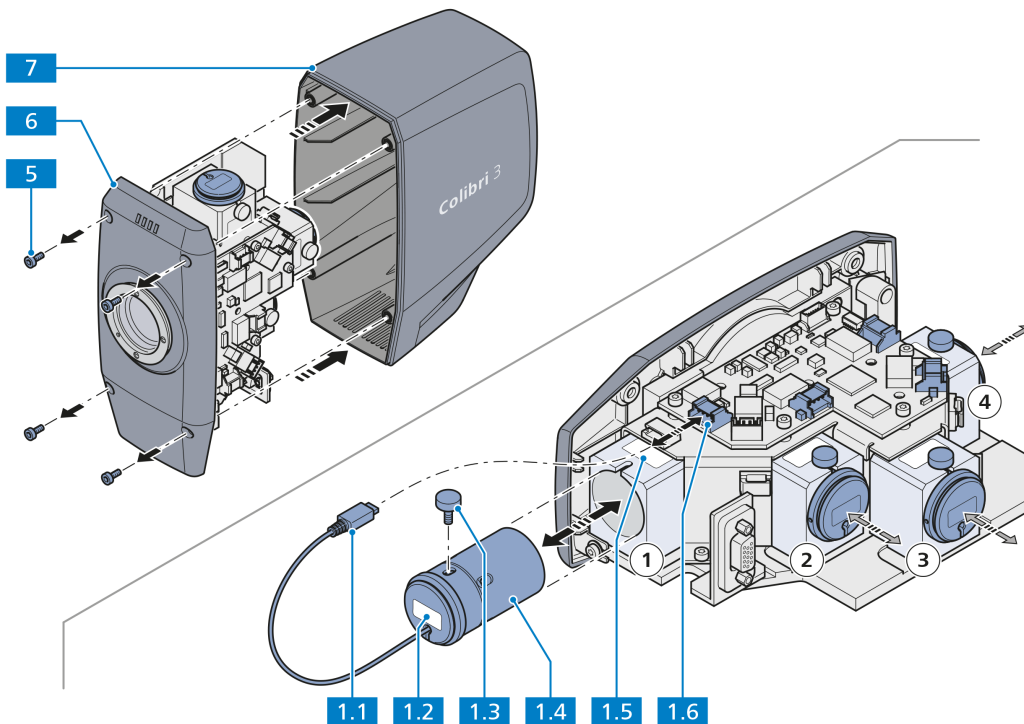

Fig. 3-38 Changing the LED modules in the Colibri 3 illumination system

Usability of LED modules for Colibri 3

Position	Wavelength range	385 nm LED 423052-9593-000	470 nm LED 423052-9573-000	505 nm LED 423052-9562-000	565 nm LED 423052-9602-000	625 nm LED 423052-9522-000
Slot 1	450~480 nm	X	O	X	X	X
Slot 2	350~415 nm	O	X	X	X	X
Slot 3	594~660 nm	X	X	X	X	O
Slot 4	508~565 nm	X	X	O	O	X

O Usable
X Not usable

3.1.23 Mounting the external illumination fixture HXP 120

Please refer to the separate operation manual of HXP 120 for instructions on installing and operating this system.

3.2 Mounting optional components



CAUTION

Always disconnect the stand and the external power supply units from the power mains before beginning any mounting work.

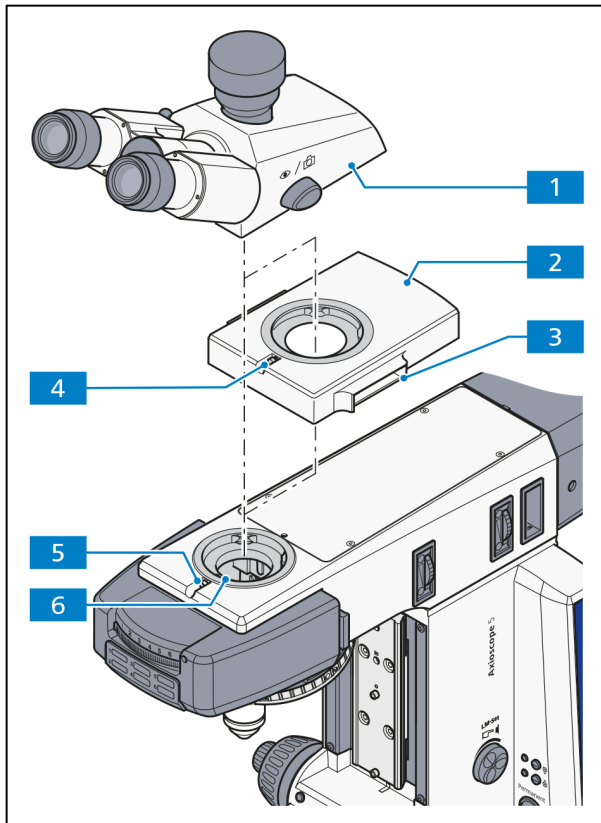

Fig. 3-39 Mounting the binocular tube with intermediate plate

3.2.1 Mounting the intermediate plate for Analyzer Slider

- Loosen the screw (Fig. 3-39/5) with the Allen wrench (AF 3) and lift off the tube (Fig. 3-39/1).
- Use the included ring tool to unscrew the tube lens (accessible from the bottom) and keep it free of dust.
- Screw the tube lens included with the intermediate plate into the tube.
- Insert the intermediate plate (Fig. 3-39/2) with the dovetail ring into the stand socket (Fig. 3-39/6), adjust it, then fasten it with the Allen screw (Fig. 3-39/4).
- Insert the analyzer slider into the slider slot (Fig. 3-39/3) if applicable.
- Slightly incline the binocular tube (Fig. 3-39/1) when inserting it into the intermediate plate, adjust it and fasten it with the Allen screw (Fig. 3-39/4).

3.2.2 Mounting the tube lens turret

Mounting the tube lens turret is done similarly to mounting the intermediate plate for analyzer sliders. See section 3.2.1.



NOTE

Before using the tube lens turret, please remove the tube lens from the used tube.

3.2.3 Mounting the magnification changer

- Remove the camera adapter or the dust protection cover from the camera port (Fig. 3-40/2) of the photo tube.
- Mount the magnification changer (Fig. 3-40/1) on the camera port, adjust it and fasten it with the retainer nut (Fig. 3-40/3).
- Mount the camera with the appropriate adapter on the camera port of the magnification changer.

The locking power for the magnification modules stop position can be adjusted with the screw located on the bottom of the magnification changer housing.

The screw is labeled with a white circle.

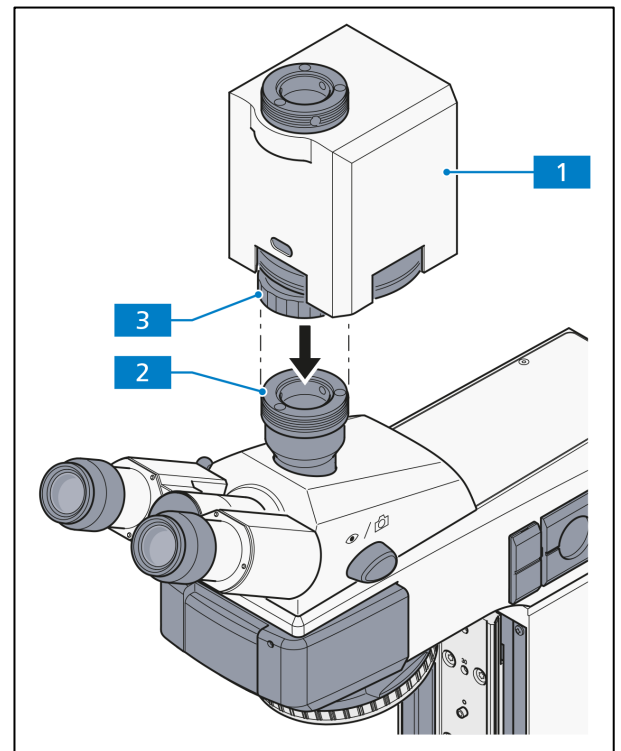

Fig. 3-40 Mounting the magnification changer

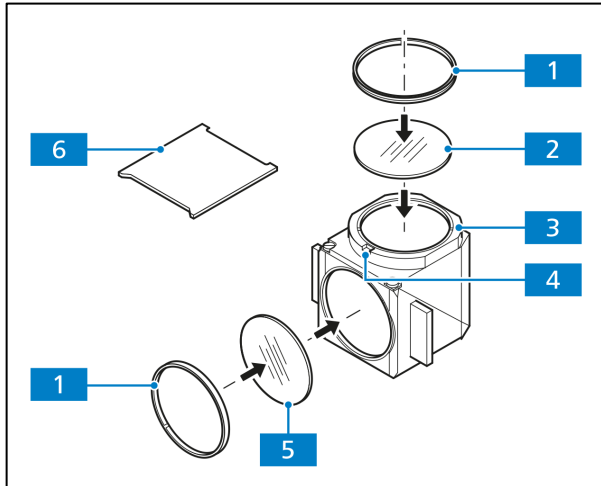

Fig. 3-41 Changing the filters in the reflector module FL P&C

3.2.4 Changing the filters in the reflector module FL P&C

- Remove the reflector module FL P&C (Fig. 3-41/3) from the reflector turret (see also section 3.1.6).
- Unscrew the adapter ring (Fig. 3-41/1) with the mounting plate included with the tools (Fig. 3-41/6).
- Turn over the reflector module and let the filter (Fig. 3-41/2 or 5) drop onto a soft surface.
- Insert the emission filter (Fig. 3-41/2) or the excitation filter (Fig. 3-41/5) respectively at the position shown in Fig. 3-41.
- Fix the filters with the corresponding adapter ring (Fig. 3-41/1).



NOTE

When LED modules (423052-9593-000 for 385 nm, 423052-9573-000 for 470 nm, 423052-9562-000 for 505 nm, 423052-9602-000 for 565 nm and 423052-9522-000 for 625 nm) are used for fluorescence, the respective excitation filter is pre-installed in the LED module instead of the reflector module.

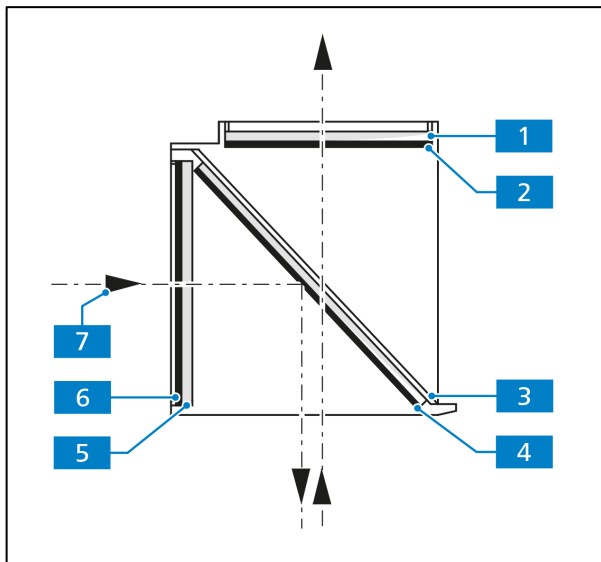

Fig. 3-42 Mounting the filters and the color splitter

The emission filter and excitation filter usually have a name and an arrow on their rims. The arrow indicates the direction of insertion and must always point to the inside of the reflector module (see arrows in Fig. 3-41). To minimize the image offset in multiple fluorescence images, the emission filter may have another mark to level the point angle.

When mounting the appropriate emission filter in the according reflector module, the mark should be aligned with the orientation groove (Fig. 3-41/4). This guarantees that the point angle in the reflector modules acts equally and compensates or minimizes the image offset – already low in ZEISS filter sets – even further.

When mounting a filter without any orientation marks (arrow), we recommend proceeding as follows:

Filters with reflective, di-electrical coatings are mounted with the reflective coating (Fig. 3-42/6) facing outward (in relation to the reflector module) in excitation filters (Fig. 3-42/5) and facing inward in emission filters (Fig. 3-42/2).

The reflective coating (Fig. 3-42/4) of the color splitter (Fig. 3-42/3) faces down when the splitter is mounted.

The arrows (Fig. 3-42/7) in the figure mark the path of the illumination beam or the imaging beam.

3.2.5 Changing the color splitter in the reflector module FL P&C



ATTENTION

Be extremely careful when installing the filters and the color splitter to avoid damaging and soiling the optical components.

We recommend ordering completely equipped reflector modules FL P&C, as changing the color splitter is very challenging.

When changing the color filter, please proceed as follows:

- Remove the reflector module FL P&C from the reflector turret (see also section 3.1.6).
- Loosen both slit screws (Fig. 3-43/1) with a screwdriver.
- Hold both parts of the reflector module (the **emission** part (Fig. 3-43/2) and the **excitation** part (Fig. 3-43/3) together, turn them against the mounting position and put them down.
- Now tilt the **excitation** part lying on top (Fig. 3-44/1) upward and lift the **emission** part (Fig. 3-44/4) from the holding fixtures (Fig. 3-44/5b).
- Remove color splitter (Fig. 3-44/2) and spring box (Fig. 3-44/3) from the bottom part of the module.
- Remove the old color splitter and carefully put the new splitter with the reflective coating facing upwards onto the spring box (Fig. 3-44/3). Put both pieces together into the bottom part of the module. Make sure that the side latch of the spring box is in the appropriate recess of the bottom part of the module.

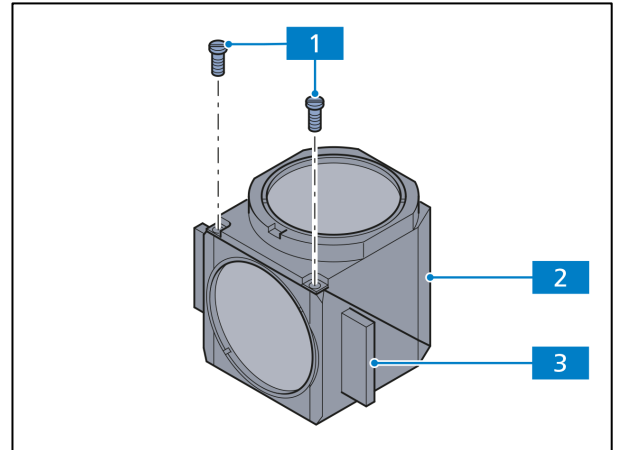

Fig. 3-43 Opening the module

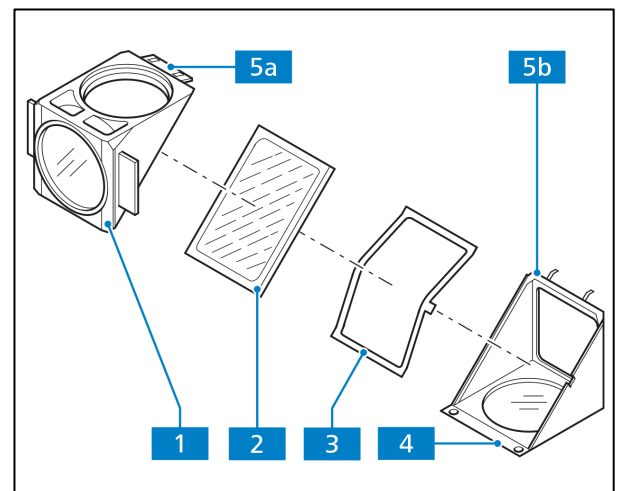

Fig. 3-44 Changing the color filter

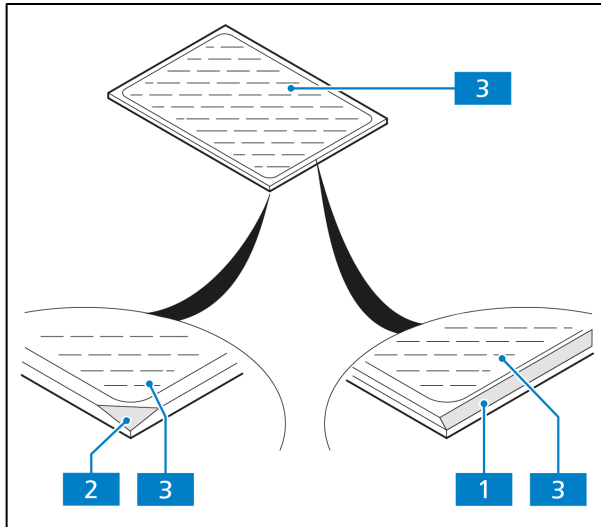

Fig. 3-45 Labeling the color splitter



NOTE

The reflective (coated) side (Fig. 3-45/3) of the color splitter has a tapered edge (Fig. 3-45/1) or corner (Fig. 3-45/2).

- Place the **excitation** part of the module (Fig. 3-44/1) on the **emission** part (Fig. 3-44/4) – holding the fixtures (Fig. 3-44/5b) and eyelet (Fig. 3-44/5a) latches together. Hold both parts together and turn them back into mounting position.
- Replace the slit screws and tighten them.
- Finally, attach the label with the name of the filter combination to the side of the module.

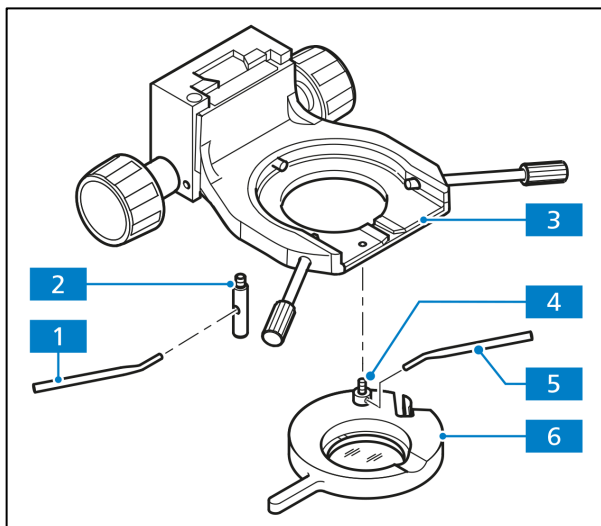

Fig. 3-46 Mounting the polarizer D

3.2.6 Mounting the polarizer D or the filter holder

- For easy assembly, remove the condenser carrier (Fig. 3-46/3) fully, with the stage carrier.
- If necessary, unscrew stop bolt and bracket bolt with low-power system from the condenser carrier.
- Hold the polarizer or filter holder (Fig. 3-46/6) parallel to the bottom of the condenser carrier (Fig. 3-46/3) and screw the bracket bolt (Fig. 3-46/4) of the polarizer (Fig. 3-46/6) with the angled adjustment lever (Fig. 3-46/5) into the front threaded opening at the left below the condenser carrier (Fig. 3-46/3) until it stops.
- Screw the stop bolt (Fig. 3-46/2) with the adjustment lever (Fig. 3-46/1) to the stop into the rear threaded opening of the condenser carrier (Fig. 3-46/3).



NOTE

Proceed similarly when mounting the other components of polarization filter carrier.

3.2.7 Mounting and centering the low-power system for 2.5x/4x objectives

- If necessary, remove the polarizer or filter holder from the condenser carrier.
- Hold the low-power system (Fig. 3-47/4) parallel to the bottom of the condenser carrier (Fig. 3-47/3) and screw the bracket bolt (Fig. 3-47/6) of the low-power system with the angled adjustment lever (Fig. 3-47/7) into the front threaded opening to the left below the condenser carrier (Fig. 3-47/3) until it stops.
- With the adjustment lever, (Fig. 3-47/1) screw the stop bolt (Fig. 3-47/2) into the rear threaded opening of the condenser barrier (Fig. 3-47/3) to the stop.
- Swing the low-power system into the beam path. Make sure that the fixture is securely engaged.
- Open aperture diaphragm and field diaphragm completely.
- Adjust both adjustment screws (Fig. 3-47/5) with the aid of two Allen wrenches (AF 1.5) until the field of view is well lit.

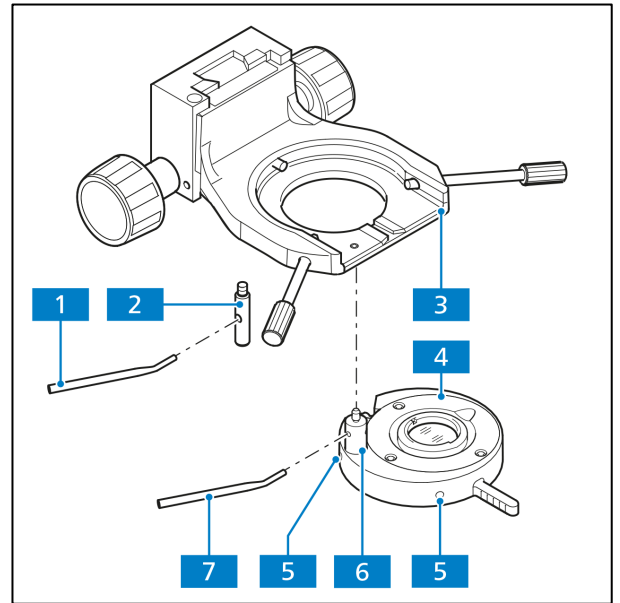

Fig. 3-47 Mounting the low-power system



NOTE

The low-power system is useful in only combination with the 0.9/1.25 condenser.

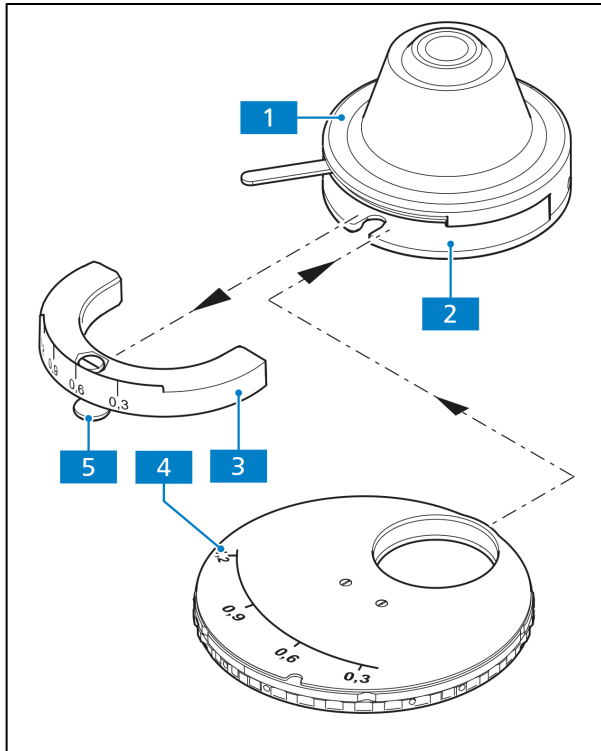

Fig. 3-48 Inserting the modulator disk in the 0.9/1.25 H condenser

3.2.8 Inserting the modulator disk in the 0.9/1.25 BF condenser

- Remove the condenser (Fig. 3-48/1) from the condenser carrier (see section 3.1.13).
If the condenser cannot be lowered sufficiently, e.g. with mounted low-power system, then it might become necessary to remove it with the stage carrier, then lower it to the stop and remove the condenser.
- Loosen the clamping screw (Fig. 3-48/5) of the condenser's dial segment (Fig. 3-48/3) with the Allen wrench (AF 3) and pull out the dial segment.
- Slide the modulator disk (Fig. 3-48/4) with its two-pronged forked opening pointing forward into the condenser. Make sure that the disk engages in the guide on both inner sides of the condenser. The guide serves as a stop for the modulator disk. The pin of the disk's clamping screw must slide into the orientation groove of the condenser.
- Tighten the disk's clamping screw with the Allen wrench (AF 3).
- Replace the condenser into its carrier (see section 3.1.13).

3.2.9 Changing the PlasDIC diaphragm

How to mount the slit diaphragm (426715-9000-000):

- Turn the PhC diaphragm that needs to be replaced into the free aperture of the modulator disk.
- Screw the modulator disk's centering screws (Fig. 3-49/5) with the aid of an Allen wrench back until they stop.
- Unscrew the adapter ring (Fig. 3-49/2) of the PhC diaphragm with the included tool (Fig. 3-49/1).
- Remove the PhC diaphragm (Fig. 3-49/4) and spring (Fig. 3-49/3).
- With the aid of the tool (Fig. 3-49/1), insert the slitdiaphragm (Fig. 3-49/7) with the cams into the orientation grooves (Fig. 3-49/6).
- Screw in the adapter ring (Fig. 3-49/8) included with the slit diaphragm with the aid of the appropriate tool (Fig. 3-49/1).

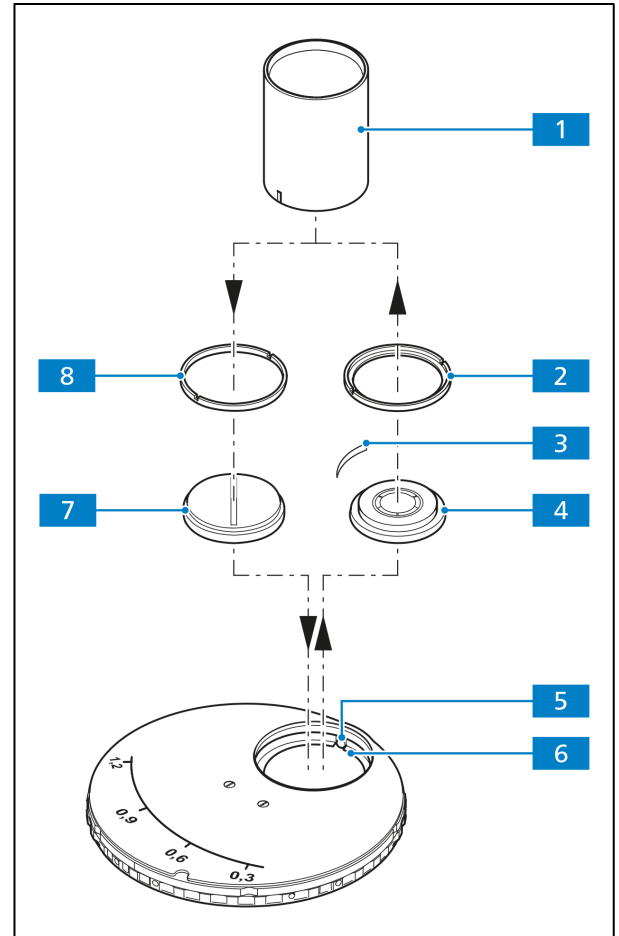

Fig. 3-49 Mounting the slit-diaphragm

3.2.10 Changing the PhC-DIC-PlasDIC diaphragm on the 0.9 BF DF PhC DIC achromatic-aplanatic condenser

The diaphragm is changed according to the directions given in sections 3.2.8 and 3.2.9.



ATTENTION

After inserting the DIC module, do not tighten the condenser's centering screw again.

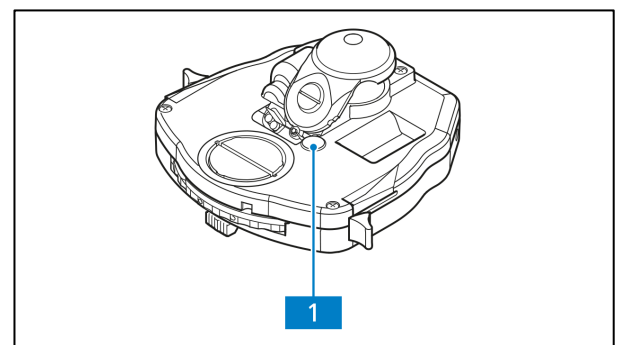

Fig. 3-50 Changing the PhC-DIC-PlasDIC diaphragm

How to deactivate the pre-set diaphragm mechanism which automatically opens the diaphragm when phase contrast occurs:

- Remove the cover (Fig. 3-50/1). Turn the screw (Fig. 3-49/5) with the Allen wrench (AF 1.5) counter-clockwise to the stop. You can now close the aperture diaphragm for contrasting procedures in DIC.

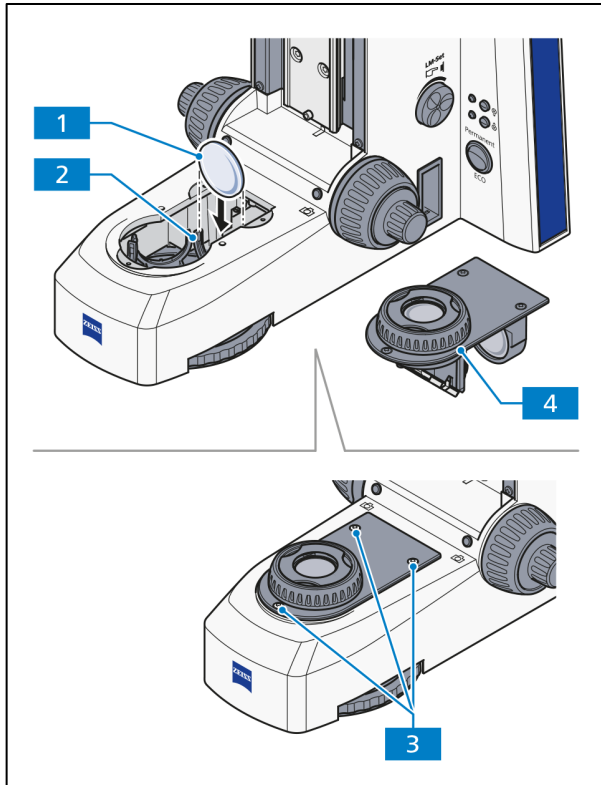

Fig. 3-51 Changing the filter in the filter wheel transmitted light

3.2.11 Changing the filter in the filter wheel transmitted light

- Remove the stage carrier (see section 3.1.12).
- Unscrew three screws (Fig. 3-51/3) of the field diaphragm socket (Fig. 3-51/4) and pull the socket out of the stand base.
- If necessary, pull the filter to be changed (Fig. 3-51/1) out of the corresponding position of the filter wheel (Fig. 3-51/2).
- Put the new filter into the position.



NOTE

One filter position is always designed as firmly installed shutter position.

- Repeat the procedure for all filter wheel positions.
- Put in the field diaphragm socket and screw it in.
- Mount the stage carrier (see section 3.1.12).

3.3 Connecting to the power supply and switching the microscope on/off

3.3.1 Microscope stand

- Connect the microscope's power supply (Fig. 3-52/2) with its power cord to an electrical outlet.

**NOTE**

The microscope can adjust to power, voltage and frequency ranges of 100 to 240 V AC, 50-60 Hz. The power supply unit adjusts **automatically** to the available voltage.

- Switch the microscope on or off with the main switch (Fig. 3-52/1) on the left side of the stand.

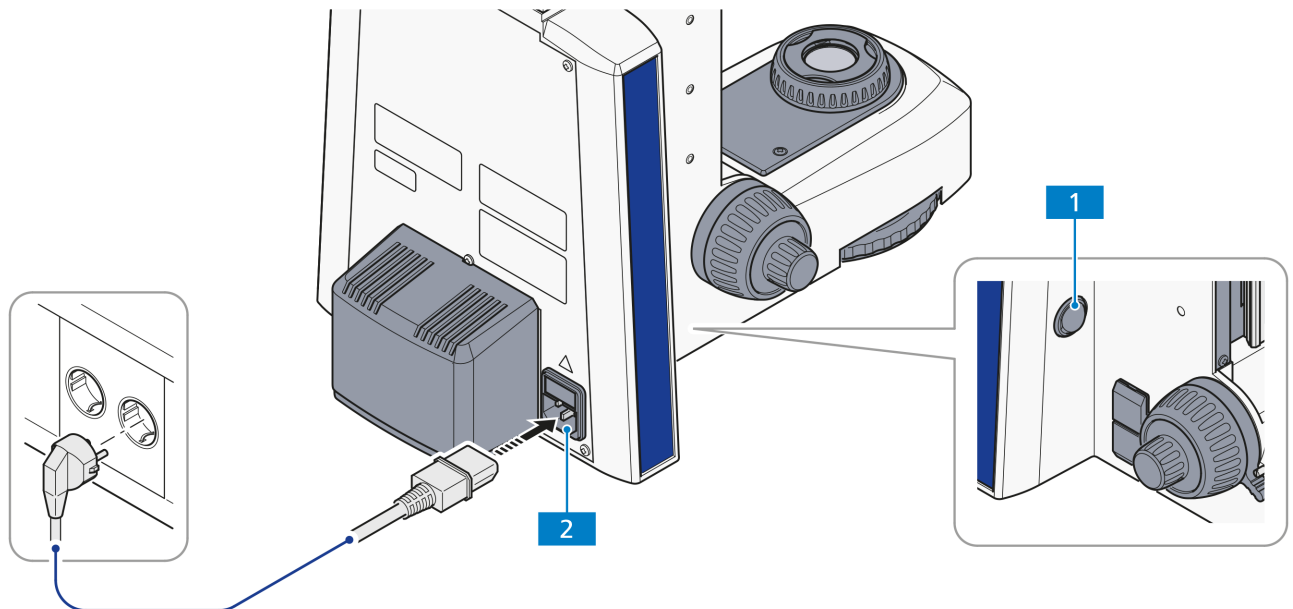

Fig. 3-52 Lower stand part for HAL 50 illumination (proceed similarly for LED illumination)

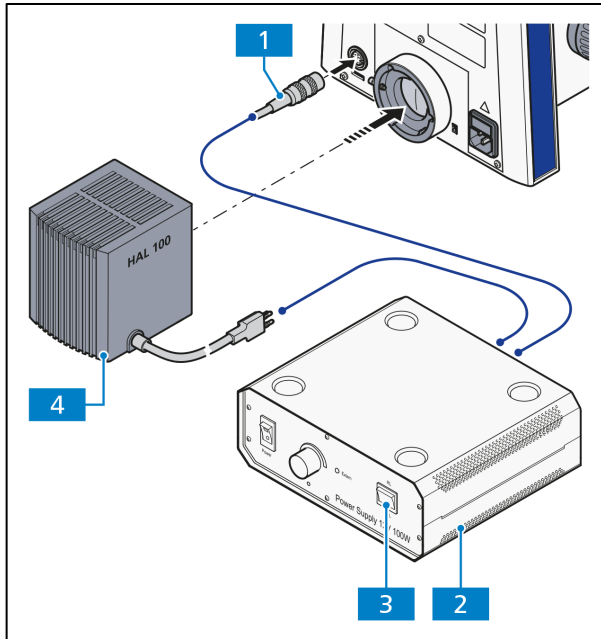

Fig. 3-53 Lower stand part for HAL 100 illumination

3.3.2 Connecting the HAL 100 halogen illuminator for transmitted light



NOTE

When using the HAL illuminator, a base plate for Axioscope (000000-2202-526) is mandatory.

- Mount the HAL 100 (Fig. 3-53/4) on the transmitted light connector of the stand (see also section 3.1.19.1).
- Connect the 3-pole lamp plug of the HAL 100 to the port for transmitted light **TL** (Fig. 3-54/3) of the separate power supply unit for two lamps (Fig. 3-53/2).
- Connect the cable for illumination intensity control (Fig. 3-53/1) to the corresponding port (**Remote**) on the back of the stand or to that of the power supply unit (Fig. 3-54/4).
- Switch the toggle switch (Fig. 3-53/3) for reflected or transmitted light to the **TL** position (transmitted light).

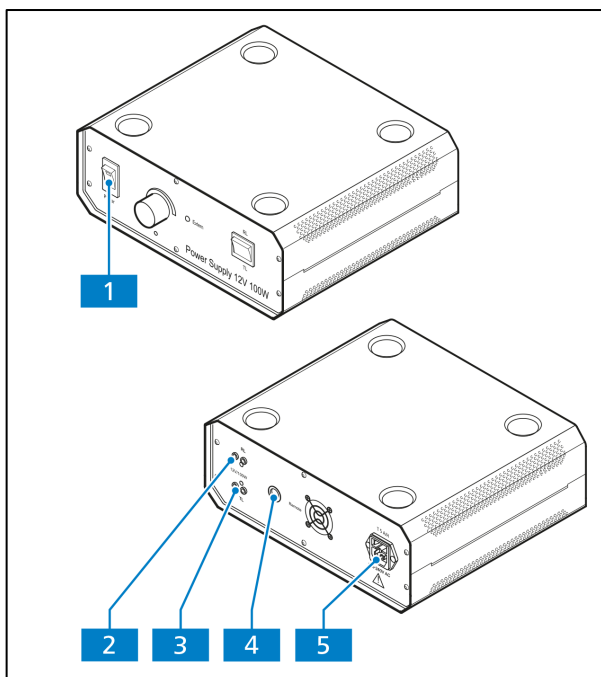

Fig. 3-54 External power supply unit for two lamps (front and back)

3.3.3 Connecting the HAL 100 halogen illuminator for reflected light

- Mount the HAL 100 on the reflected light connector of the stand (see section 3.1.19.1).
- Connect the 3-pole lamp plug of the HAL 100 to the port for reflected light **RL** (Fig. 3-54/2) of the separate power supply unit for two lamps.
- Connect the power cord of the external power supply unit (Fig. 3-54/5) to an electrical outlet.
- Switch the toggle switch for reflected or transmitted light to the **RL** position (reflected light).

3.3.4 Switching the illumination on/off

- Turn the power switch (Fig. 3-52/1) of the microscope with the lower part of the stand for LED or HAL 50 illumination either on or off.
- Switch on the halogen illuminator for transmitted light (lower stand part for HAL 100 illumination) and reflected light (if in use) at its separate external power supply unit (Fig. 3-54/1) (also refer to the separate operation manual of the external power supply unit). Depending on whether you want to use the illuminator for reflected light or the illuminator for transmitted light, switch the toggle switch (Fig. 3-53/3) for reflected or transmitted light to the **TL** position (for transmitted light) or to the **RL** position (for reflected light).
- Switch the HBO 100 illuminator for overhead fluorescence light (if in use) on or off with the power switch of the power supply unit for HBO 100 (Fig. 3-55/1).

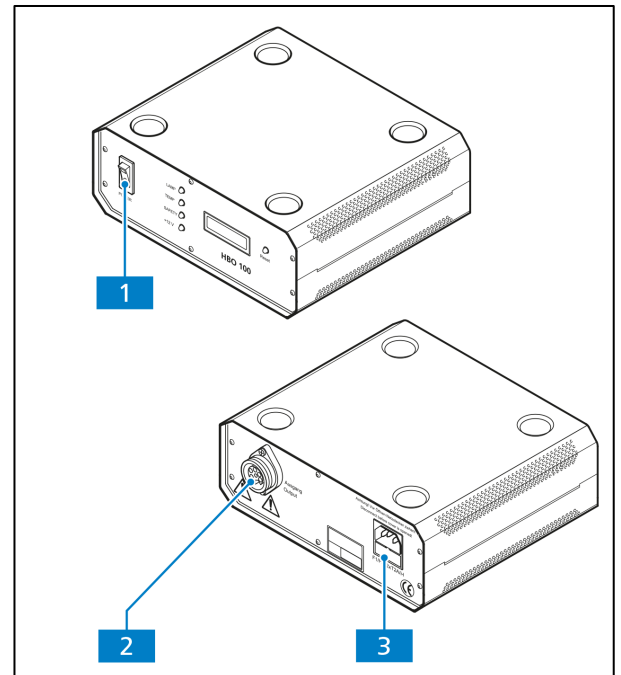



Fig. 3-55 Power supply unit for HBO 100 (front and back)

	<p>NOTE</p> <p>If the control cable (Remote) is connected (see section 3.3.2) to the stand, the illumination intensity of the HAL 100 illuminator for transmitted or reflected light, depending on which is switched on, can be varied by rotating the Intensity/LM knob (Fig. 2-2/6) on the lower part of the stand.</p>
	<p>NOTE</p> <p>If the control cable is not connected to the stand, the illumination intensity of the HAL 100 illuminator in use can be varied by rotating the knob of the external power supply unit.</p>

3.4 Using the Light Manager function

When turned on, the previous setting of the Light Manager will be restored.

The LM function is enabled automatically if the default factory settings are active.

Disable/enable the LM function

To disable the LM function proceed as follows:

- Press one of the **Snap** buttons **and** the **Intensity/LM** knob simultaneously for at least 1.5 seconds.

The indicator light blinks GREEN / ORANGE / GREEN in sequence.

To enable the use of the LM function proceed as follows:

- Press one of the **Snap** buttons **and** the **Intensity/LM** knob simultaneously for at least 1.5 seconds.

The indicator light blinks GREEN / GREEN / GREEN in sequences.

Save the light intensity using the LM function

- Press the **Intensity/LM** knob for at least 1.5 seconds.

The currently set light intensity value will be saved. After it is saved, the active LED illuminator switches off for 300 ms. The darkness in the eyepieces indicates the successful action of the Light Manager.



NOTE

If the Colibri 3 light source is connected, the Light Manager function is not available.

3.5 Default factory settings of the microscope

The default factory settings are:

- Light Manager enabled
- Light intensity set to initial minimum value
- all configuration stored will be cleared

To reset the microscope to default factory settings, proceed as follows:

- Press and hold down the **Intensity/LM** knob for 20 seconds.

While the knob is held down from 3 s to 20 s, the indicator light blinks in RED.

It blinks GREEN after 20 seconds. When the indicator stops blinking and remains GREEN, the reset to the default factory setting is successful.

4 OPERATION

4.1 Default setting of the microscope

4.1.1 Setting the inter-pupillary distance on the binocular tube

- Adjust the individual inter-pupillary distance by symmetrically swiveling of the two eyepiece tubes towards each other (Fig. 4-1).

The correct inter-pupillary distance has been set when the observer sees only **one** round image when looking into the eyepieces!

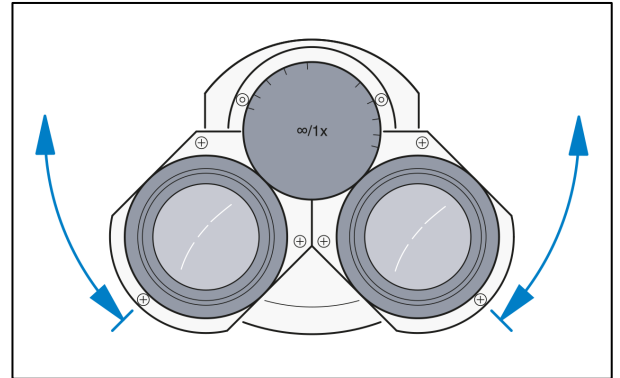

Fig. 4-1 Setting the inter-pupillary distance on the binocular tube

4.1.2 Setting the viewing height

- Adjust the viewing height to your individual requirements by swiveling the eyepiece tubes up (Fig. 4-2/A) or down (Fig. 4-2/B).

The binocular ergonomic (photo) tubes (425511-0000-000, 425512-0000-000, 445514-0000-000 and 425520-9050-000) are equipped with a continuous height adjustment in the range from 44 mm to 50 mm.

The binocular piece of the ergo tube 425520-9050-000 can also be pulled out horizontally by 50 mm.

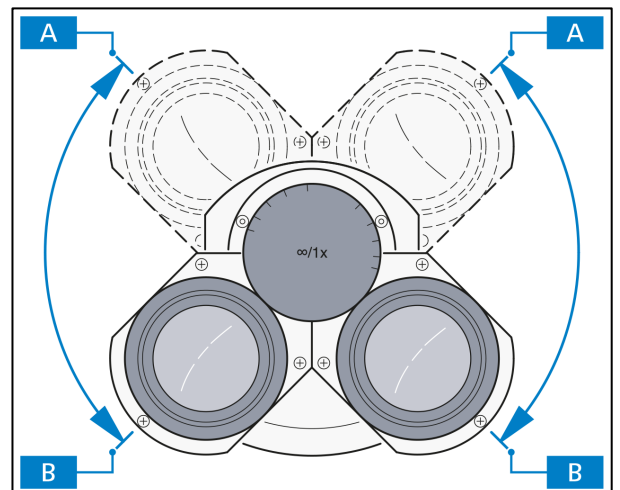

Fig. 4-2 Setting the viewing height on the binocular tube

4.1.3 Adjusting for ametropia (user's visual impairment) when using eyepiece reticles

The prerequisite for the correct use of an eyepiece reticle is two adjustable eyepieces (e.g. PL 10x/23 GW foc.) to compensate for different degrees of ametropia of the user.

To adjust the eyepieces for different degrees of ametropia, follow the subsequent steps:

- Focus on the line figure of the eyepiece reticle with the focusable eye lens of the adjustable eyepiece.
- Focus on the microscopic image of a loaded specimen with the focusing drive while observing with the eyepiece containing the eyepiece reticle.
- When both the microscopic image and the eyepiece reticle are in focus, the image for the second eye is brought into focus with the focusable eye lens of the second eyepiece.

Both microscopic images including the eyepiece reticle are thus in focus. From this point, use only the focusing drive to focus images.

4.2 Illumination and contrast methods in transmitted light microscopy

4.2.1 Setting up transmitted light brightfield microscopy using the KÖHLER method

(1) General principle of operation

Of all the optical microscopy methods, transmitted light brightfield microscopy is the one most commonly used. High-contrast or tinted (stained) samples (e.g. a blood smear) can be examined easily and quickly.

For an imaging result which is as true to the specimen as possible, we must not only consider the so-called direct bundled beams but the indirect ones as well, i.e. the beams which diffract and scatter on the sample details. According to ABBE, the image is truer to the specimen when the fraction of the cone of light is as large as possible.

The best performance of the microscope, and especially its objective, is achieved when the condenser, field diaphragm and aperture diaphragm are adjusted in accordance with the KÖHLER illumination principles. These fundamental basic rules for adjusting a microscope are explained in detail in section 4.2.1 (3) "Setting up transmitted light brightfield microscopy using the KÖHLER method".

(2) Instrumentation for transmitted light brightfield microscopy

Every microscope (except the one with the Vario stand column) is configured to work with the transmitted light brightfield method.

All available condensers (except special condensers like darkfield condensers) can be used for the transmitted light brightfield method.

(3) Setting up transmitted light brightfield microscopy using the KÖHLER method

- The Axioscope has been put into operation appropriately (section 3).
- The Axioscope is turned on.
- Adjust the image brightness using the Intensity/LM knob (Fig. 4-3/1) on the microscope stand.
- Put a high-contrast sample into the specimen holder of the mechanical stage.
- If condensers with a swiveling front lens are used, swivel these into the beam path with $\geq 10\times$ objectives and turn the knurled knob for vertical adjustment of the condenser (Fig. 4-3/3 and Fig. 4-4/2) to the top stop. Make sure the stop is adjusted to prevent the condenser from lifting out the sample (adjusting the condenser stop, section 4.2.1 (4)).
- On condensers with revolver/modulator disks: turn the knurled ring (Fig. 4-4/3) to position **H** (or **B** = brightfield).
- Bring the 10x objective into position on the nosepiece (Fig. 4-3/6) and focus the sample using the focus drive (Fig. 4-3/2).
- Close the field diaphragm (Fig. 4-3/5) enough to make it visible in field of view (even if blurred) (Fig. 4-3/A).
- Lower the condenser using the knurled knob for vertical adjustment until the edge of the field diaphragm appears sharp (Fig. 4-3/B).

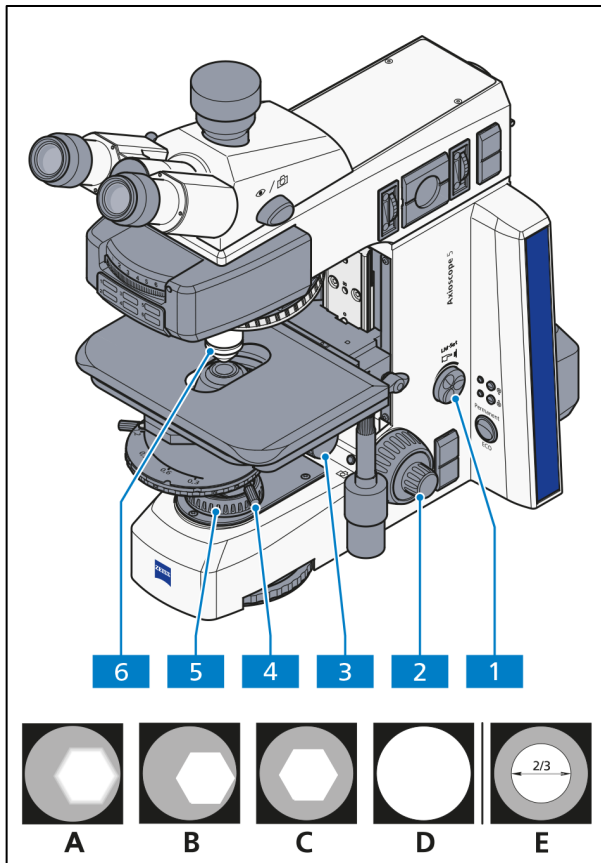

- Center the field diaphragm image with both centering screws (Fig. 4-3/4) on the condenser carrier (Fig. 4-3/C).
- Open the field diaphragm enough to make the edge of the diaphragm disappear from the field of view (Fig. 4-3/D).
- To adjust the aperture (contrast), take an eyepiece from the tube barrel. Looking through the barrel adjust the aperture with the adjusting lever (Fig. 4-4/4) of the aperture diaphragm to the size of approx. $2/3$ - $4/5$ of the diameter of the objective exit pupil (Fig. 4-3/E). In most cases this aperture gives the best contrast at almost full resolution and is thus the best compromise for the human eye.
- Replace the eyepiece in the tube barrel.

Fig. 4-3 Microscope adjustment in transmitted light brightfield microscopy



NOTE

Each objective changes the size of the object field and the objective aperture. The centering might also vary slightly from objective to objective, so that an adjustment of field diaphragm and aperture might become necessary for optimal results.

With objectives $< 10\times$, the front lens of the condenser (if swivelable) must be swiveled out of the beam path and the aperture opened fully. In order to achieve a better contrast, the field diaphragm can be pulled closer when working with large object fields. To do this you must reduce the opening by a certain range. Avoid closing it too much to guarantee a consistent illumination of the field of view.

(4) Adjusting the height stop on the condenser carrier

- Loosen the setscrew (Fig. 4-4/1) on the height stop with the Allen wrench (AF 3).
- Focus the sample with the focusing drive.
- Close the field diaphragm and adjust the condenser vertically (Fig. 4-4/2) until you get a sharp image.
- Perform the vertical adjustment on the condenser by small increments only to avoid lifting out the sample.
- Tighten the setscrew (Fig. 4-4/1) on the height stop.

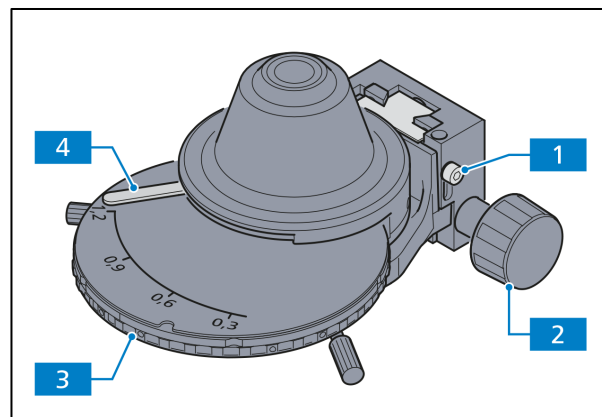

Fig. 4-4 Adjusting the height stop on the condenser carrier

(5) Adjusting the height stop on the focusing drive

- Turn the clamping lever (Fig. 4-5/1) of the stop towards the pin stop.
- Move the stage with the aid of the focusing drive (Fig. 4-5/2) to the highest position allowable without risking colliding with specimen holder or objectives.
- Now press the clamping lever down until the stop engages again.

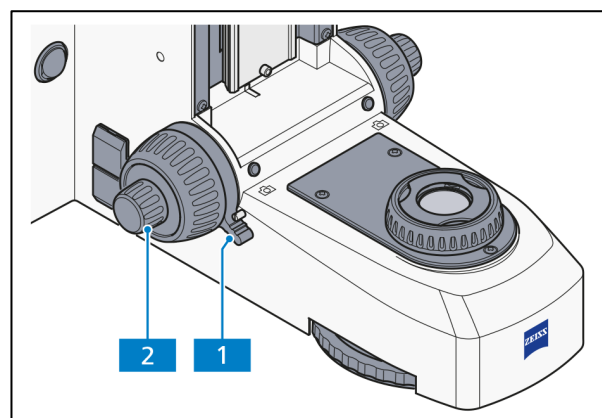

Fig. 4-5 Adjusting the height stop on the focusing drive

4.2.2 Setting up transmitted light darkfield microscopy using the KÖHLER method

(1) General principle of operation

Uncolored biological samples, like bacteria or living cell cultures, are sometimes hard to see in transmitted light brightfield microscopy due to their translucence. Yet it is completely different when you examine these samples with the transmitted light darkfield method. You basically illuminate the sample with an illumination aperture which is higher than the one of the objective you are using.

In darkfield microscopy, only the diffracted and scattered light portions which are important for the imaging procedure get into the objective, whereas the indirect unaffected light beams are directed past the objective. Thus a resolution of fine structures is achieved which is partially below the resolution capacity of a light microscope. The fine structures now appear bright and incandescent on a dark background.

(2) Instrumentation

Condenser with transmitted light stop in position **D** e.g.:

- Condenser 0.9/1.25 H with modulator disk BF, DF, PhC 1, PhC 2, PhC 3,
- Condenser, achrom.-aplan. 0.9 BF DF PhC DIC,
- Darkfield condenser with dry darkfield (465505-0000-000 applicable aperture from 0.6 – 0.75),
- Ultra-condenser (465500-0000-000 applicable aperture from 0.75 – 1).

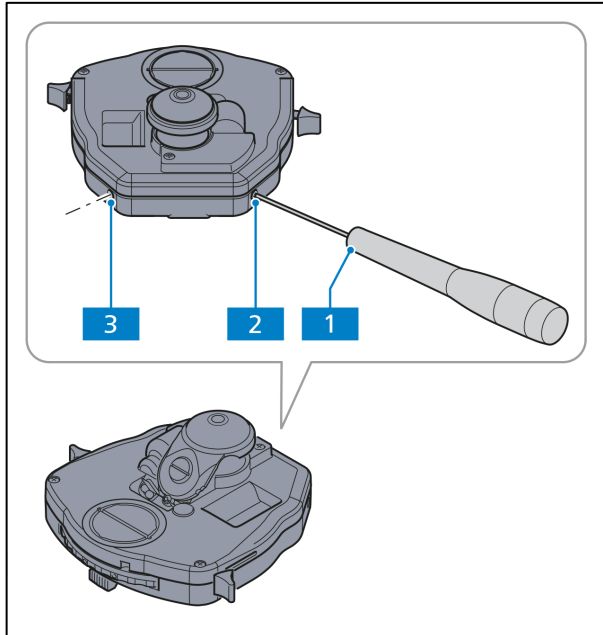

Fig. 4-6 Centering the darkfield diaphragm on the condenser, achromatic-aplanatic 0.9 H D PhC DIC

(3) Setting up transmitted light darkfield microscopy

- Adjust the KÖHLER illumination as for transmitted light brightfield microscopy. Instead of the 10x objective it is necessary to use an objective with the highest possible aperture. The aperture must not exceed the aperture of the condenser being used.
- Set the revolver/modulator disks to position **D** and bring the condenser front lens into position (if applicable).
- Take the eyepiece out of the tube (or replace it with the auxiliary microscope) and check the centering of the darkfield diaphragm in the objective exit pupil. If the DF central darkfield diaphragm in the universal condenser is partially outside or is not centered to the objective exit pupil and the pupil does not appear consistently dark, it is necessary to re-adjust the centering of the darkfield diaphragm.
- If the darkfield diaphragm needs to be centered, use two Allen wrenches (AF 1.5) (Fig. 4-6/1) and adjust the two centering screws (Fig. 4-6/2 and 3) until the objective exit pupil appears consistently dark. Remove the Allen wrenches (AF 1.5) from the condenser after finishing the centering procedure.

**NOTE**

Objectives with built-in iris apertures have apertures which are too high for the transmitted light darkfield microscopy. Stop the iris aperture down at least until it reaches the border aperture for the darkfield of the condenser in use.

Performance criterion for the darkfield method is always the darkest possible background for the field of view.

- Replace the eyepiece in the tube.
- Lighter areas which might still be visible in the field of view are reduced when the darkfield condenser is adjusted correctly and delicately. You now have an approximately sharp eye diaphragm image.
- Now adjust the field diaphragm diameter to the size of the field of view.

Darkfield samples need to be kept impeccably clean, more so than samples for any other method. A fingerprint, dust or any dirt particle can have a negative effect, as they brighten the background and reduce the contrast of the object image.

(4) Setting darkfield contrast with a dry darkfield condenser

- If necessary, swivel out the low-power system, polarizer or λ plate.
- Move the condenser carrier down until the end stop.
- Place the dry darkfield condenser in the condenser holder Z (see section 3.1.14).
- Place the condenser holder Z in the condenser carrier and center it roughly, so the condenser fits into the opening of the mechanical stage without contact, when moving upwards.
- Move the condenser up until the end stop. Place the specimen and adjust the illumination intensity to bright enough.
- Swivel in an objective with small magnification (e.g. 5x or 10x) and focus the specimen, using the focusing drive.
- Place a specimen as its details are distributed evenly in the field of view. This will make the image of the field diaphragm easier to identify.
- Close the field diaphragm until the end stop.
- Lower condenser until edge of field diaphragm appears sharp (luminous-field diaphragm focus level). There will be an increasing or decreasing light ring visible, when moving the focus upwards or downwards from the field diaphragm focus level (so called circular "breathing" of the field diaphragm depiction).
- Center the field diaphragm image with both centering screws on the condenser carrier.
- Swivel in the desired objective.
- Focus the specimen with the focusing drive, if necessary.
- Focus the field diaphragm, using the condenser drive. Open the field diaphragm enough to make the edge of the diaphragm disappear from the field of view.
- Optimize the contrast with the condenser, if necessary.

(5) Setting darkfield contrast with immersion oil darkfield condenser

- If necessary, swivel out the low-power system, polarizer or λ plate.
- Move the condenser carrier down until the end stop.
- Place the immersion oil darkfield condenser in the condenser holder Z (see section 3.1.14).
- Place the condenser holder Z in the condenser carrier and center it roughly, so the condenser fits into the opening of the mechanical stage without contact, when moving upwards.
- Move the condenser up until the end stop.
- Place a drop of immersion oil (without bubbles, if possible) on the center of the condenser front lens.
- Place a specimen. The immersion oil will disperse between condenser and specimen holder.
- Slightly move the mechanical stage back and forth to dissipate any air bubbles in the immersion oil.
- Adjust the illumination intensity to bright enough and open the field diaphragm completely.
- Swivel in an objective with small magnification (e.g. 10x) and focus the specimen, using the focusing drive.
- Center the field diaphragm on the condenser carrier with the adjustment screws and focus the image with the condenser drive.
- Place a drop of immersion oil on the specimen holder, swivel in immersion oil objective and focus the specimen.
- Close the field diaphragm until the end stop.
- Lower condenser until edge of field diaphragm appears sharp.
- Center the field diaphragm image with both centering screws on the condenser carrier.

The luminous field diaphragm appears only as a circle segment on the edge of the viewing field due to the high magnification of the immersion oil objective. As a result, the focusing and centering of the field diaphragm must be repeated. If necessary, the luminous-field objective should be opened slightly if the light intensity is too low.

The field diaphragm is centered properly when the edge of the luminous field diaphragm is centered or equidistant from the viewing field edge.

- For a sharply focused specimen, open the sharply set field diaphragm enough to make the edge of the diaphragm disappear from the field of view.
- You can improve the contrast of the microscope image by slightly adjusting the focus level of the condenser with the condenser drive.
- The background of the eyepiece image should appear equally dark.
- For immersion oil objectives with an iris diaphragm, the contrast can be further optimized by turning the adjustment of the iris diaphragm.

4.2.3 Setting up transmitted light phase contrast microscopy

(1) General principle of operation

The phase contrast method is ideal for examining thin uncolored samples, e.g. culture cells. Generally, the human eye cannot detect phase differences (variations in refractive index or thickness) within the different cell components.

The phase contrast method uses optical modulators such as the "annular phase diaphragm and phase ring" to convert the small phase differences in intensity and color differences which are visible to the human eye. The interference of different beams in the intermediate image is important for the generation of such images.

With the aid of the optically defined ring channel "annular phase diaphragm and phase ring", the high-intensity direct light portions are attenuated and provided with a constant phase shift. The indirect light portions, however, which are diffracted by different cell particles, bypass this optical channel and their phase is affected by the difference in the sample's refractive index and thickness.

In the intermediate image plane, the partial beams are thus differently affected and achieve interference and strengthen or weaken each other (constructive and destructive interference) – depending on their phase. As a result, these interferences create image contents with intensity differences visible to the human eye.

(2) Instrumentation

- Phase contrast objectives with the phase rings PhC 1, PhC 2 or PhC 3 for various medium numeral apertures which can also be used in the brightfield.
- Condenser with revolver/modulator disk which contains centerable ring diaphragms PhC 1, PhC 2 and PhC 3 for various medium numeral apertures.
- The phase annular diaphragm used on the condenser must be consistent with the labeling on the objective which is used, e.g. PhC 1.

(3) Setting up transmitted light phase contrast microscopy

- Swivel the phase contrast objective, e.g. labeled Ph **1**, into the beam path.
- Switch on the annular phase diaphragm on the condenser's revolver disk which has the same label as the phase contrast objective, e.g. 1.
- In order to check the centering and the overlap of the lighter annular diaphragm (in the condenser) with the darker phase ring (in the objective), remove an eyepiece from the tube and replace it with an auxiliary microscope. Use the adjusting fixture on the auxiliary microscope to focus the annular diaphragm and the phase ring in the objective exit pupil.

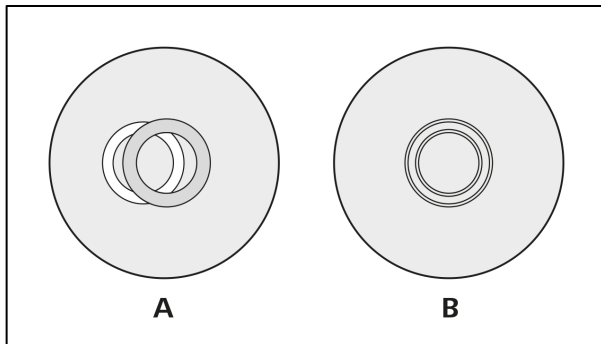

Fig. 4-7 Centering the annular phase diaphragm (light-colored, in the condenser) and the phase ring (dark-colored, in the object)

- If the overlap is not exact (Fig. 4-7/**A**), the lighter annular diaphragm must be re-centered with the aid of two Allen wrenches (AF 1.5) (Fig. 4-6/**1** and **4**). Adjust the two centering screws (Fig. 4-6/**2** and **3**) so that you achieve a full overlap with the darker phase ring (Fig. 4-7/**B**).
- Remove the auxiliary microscope from the tube and replace it with the eyepiece.

To increase the image contrast, a green 32 x 4 interference broadband filter may be mounted on the field diaphragm or inserted into the color glass carrier (if available).

A complete phase contrast can only be achieved when the light-colored annular diaphragm (in the condenser) overlaps exactly with the dark-colored phase ring (in the objective) in the illumination beam path (Fig. 4-7/**B**).

4.2.4 Setting up transmitted light differential interference contrast (DIC) microscopy

(1) General principle of operation

The transmitted light DIC method allows for a high-contrast vivid display of transparent sample details.

The light is linearly polarized by a polarizer and is separated into two beams in a birefringent prism. The two beams penetrate two parts of the sample which are closely separated. They experience different path differences due to the different refractive indices or different sample thickness. Both beams are then reunited in a second double refractive prism and have after passing the analyzer the same polarization. Therefore both beams can interfere in the intermediate image and the path differences are thus converted into intensity differences represented by a gray scale. A compensator or λ -plate may be used for a consecutive conversion of the gray scale in a color scale.

(2) Instrumentation

- Objectives equipped with DIC fixtures, e.g. EC-Plan-Neofluar objectives
- Nosepiece with slot for DIC slider
- DIC slider, compatible with the objectives in use
- Condenser with turret disk containing DIC prisms (e.g. condenser, achromatic-aplanatic 0.9 H D PhC DIC)
- Analyzer module ACR P&C for transmitted light in the reflector turret/slider or analyzer slider D/A fixed or rotatable in conjunction with a mounted intermediate plate for analyzer slider 12x46
- Rotatable mechanical stage, if necessary

(3) Setting transmitted light DIC

- Put the DIC compatible objective (Fig. 4-8/3) in place on the nosepiece. Slide the according DIC slider (Fig. 4-8/1) into the slit of the appropriate objective position. Make sure that the slider engages firmly.
- Swing in the analyzer module (Fig. 4-8/6) on the reflector turret (Fig. 4-8/7) (or slide the analyzer slider into the intermediate plate for analyzer sliders).
- Swing in the DIC prism (position **DIC** on the condenser) (Fig. 4-8/4).
- Adjust field diaphragm and aperture diaphragm according to the KÖHLER method.
- Adjust the optimal contrast on the DIC slider (Fig. 4-8/1) with the knurled screw (Fig. 4-8/2). Symmetrical adjustment of the DIC slider along its middle position lets the sample details appear as if they were elevated or deepened.
- If desired, the compensator λ (Fig. 4-8/5) can be put into the opening above the nosepiece in order to create a chromatic DIC contrast.



NOTE

The DIC method functions with polarized light. It is disturbed when birefringent elements, e.g. foils, are put between polarizer and analyzer, as is sometimes done when doing a histological incision. The same situation occurs with Petri dishes or specimen holders which have a plastic base. In these cases we recommend using PlasDIC.

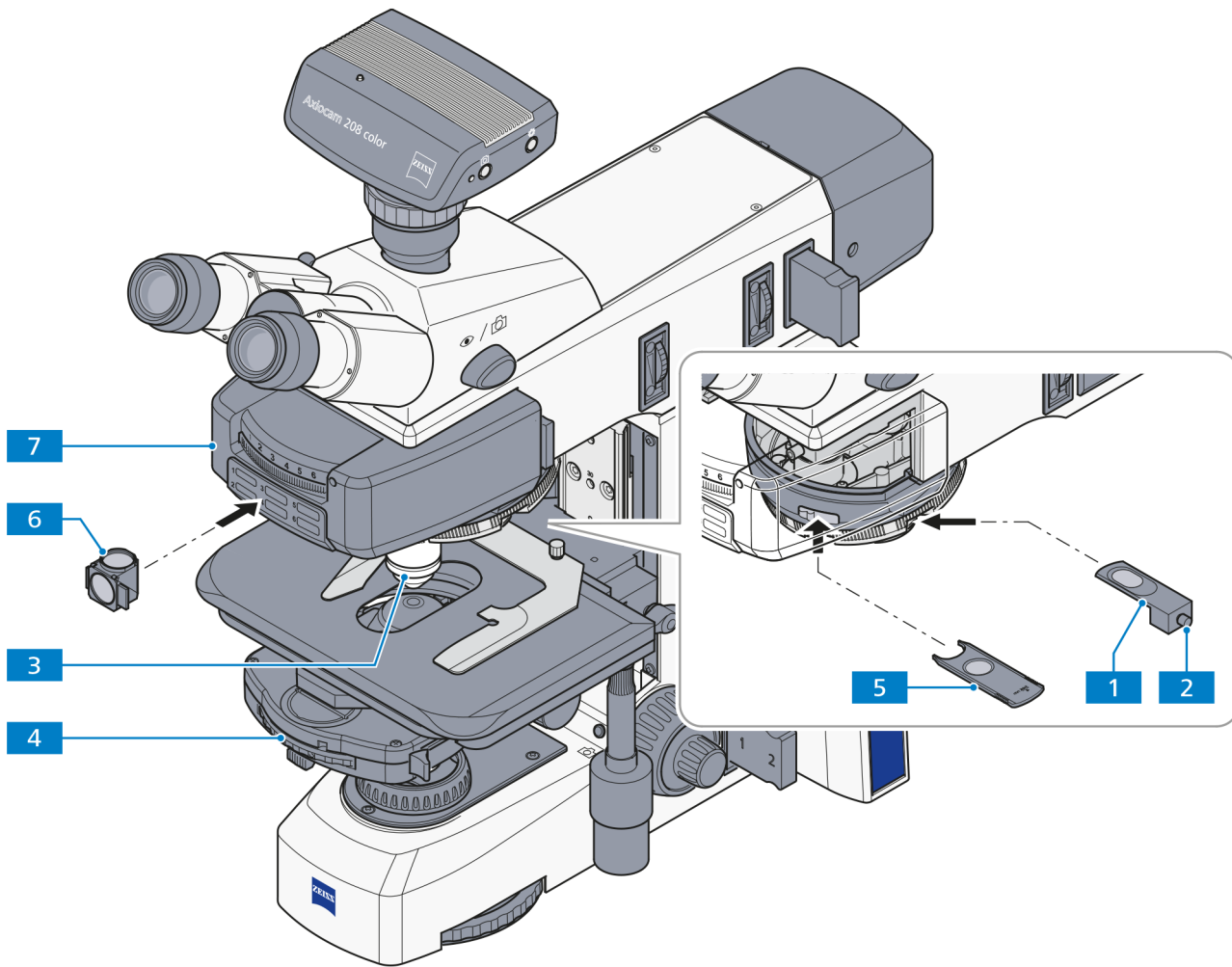

- 1 DIC slider
- 2 Knurled screw
- 3 Objective on the nosepiece
- 4 Condenser with DIC prism
- 5 Compensator λ
- 6 Analyzer module
- 7 Reflector turret

Fig. 4-8 Components for the transmitted light DIC method

4.2.5 Setting up transmitted light PlasDIC contrast microscopy

(1) General principle of operation

PlasDIC can be used independently from the material of the specimen holder.

The contrast method gives a relief-like image and is especially well suited for thicker objects. The contrast is adjustable. It is possible to contrast the cavities of microtiter plates up to the edge. It is not necessary to use cultivation holders with a glass base.

(2) Instrumentation

- Abbe condenser with modulator disk and objective-dependent 2 mm slit diaphragm (A-Plan 10x and LD A-Plan 20x) or 4.5 mm slit diaphragm (in all other cases)
- Objectives:
 - A-Plan 10x, 20x, 40x;
 - LD A-Plan 20x, 32x, 40x;
 - LD Plan-Neofluar 20x, 40x, 63x
- PlasDIC slider depending on the objective
- ACR P&C analyzer module for transmitted light and reflector turret /slider or D/A fixed or rotatable analyzer slider in connection with mounted intermediate plate for analyzer slider 12x46

(3) Setting PlasDIC

- Fully open the aperture on the condenser.
- Place the sample on the stage.
- Swing the position with the 2 or 4.5 mm slit diaphragm for PlasDIC of the condenser into the beam path. Increase brightness when switching from brightfield to PlasDIC.
- Swing the analyzer module into the beam path or slide analyzer slider in beam path in intermediate plate.
- Swing in the objective for PlasDIC.
- Slide the PlasDIC slider on the nosepiece into the DIC slit of the objective in use.
- Adjust the contrast with the knurled screw of the PlasDIC slider. You can now see the structures in relief or in pseudo-darkfield. The best result is achieved in the relief mode.

4.2.6 Setting transmitted light polarization

4.2.6.1 Detecting birefringence

(1) Application

The transmitted light polarization method is used for samples which change the polarization of the light. Such samples are called birefringent. Examples include crystals, minerals or polymers. If such birefringent substances are observed between crossed polarizers, the birefringent portion of the sample appears bright while its surroundings remain dark.

A birefringent substance can be recognized by turning the sample by 360° between crossed polarizers. The sample should show four bright and four dark appearances during the turning procedure. During the turning procedure, interference colors appear that range from gray (mostly for biological samples) through white, yellow and red until blue, depending on birefringence, thickness as well as sample orientation. The interference colors may be of the first or a higher order.

(2) Instrumentation

- Strain-free objectives
- Pol rotary stage
- D Polarizer (rotatable or fixed), if no polarizer is already integrated in the condenser.
- ACR P&C analyzer module for transmitted light in the reflector turret/slider or D analyzer slider fixed or with lambda-plate.
- Depolarizer for avoiding unwanted polarizing effects

A depolarizer (quartz depolarizer) should be incorporated in all microscopes used to examine mineralogical/geological specimens.

A depolarizer extinguishes undesirable polarization effects possibly (e.g. false or pseudo-pleochroism) occurring behind the analyzer (e.g. on prism surfaces in the tube), or shifts them to higher orders.

- Insert the quartz depolarizer with tube lens 115 (428106-9010-000) into the tube

or

- insert the quartz depolarizer with tube lens 130 in combination with intermediate plate (428106-9000-000) into the tube.

(3) Setting the microscope

- Adjust the microscope as described in section 4.2.1 (3) for transmitted light brightfield microscopy using the KÖHLER method.
- Center the rotary stage Pol (Fig. 4-9/1) (see section 3.1.10.5) and objectives (see section 3.1.10.6).
- Swing the polarizer (Fig. 4-9/3) into the beam path and position it to 0° if you are using a rotatable polarizer.
- Put the analyzer (Fig. 4-9/2) into the slit for the compensator or swing analyzer module on the reflector turret/slider. Because of the crossed polarizers the field of view now appears dark.

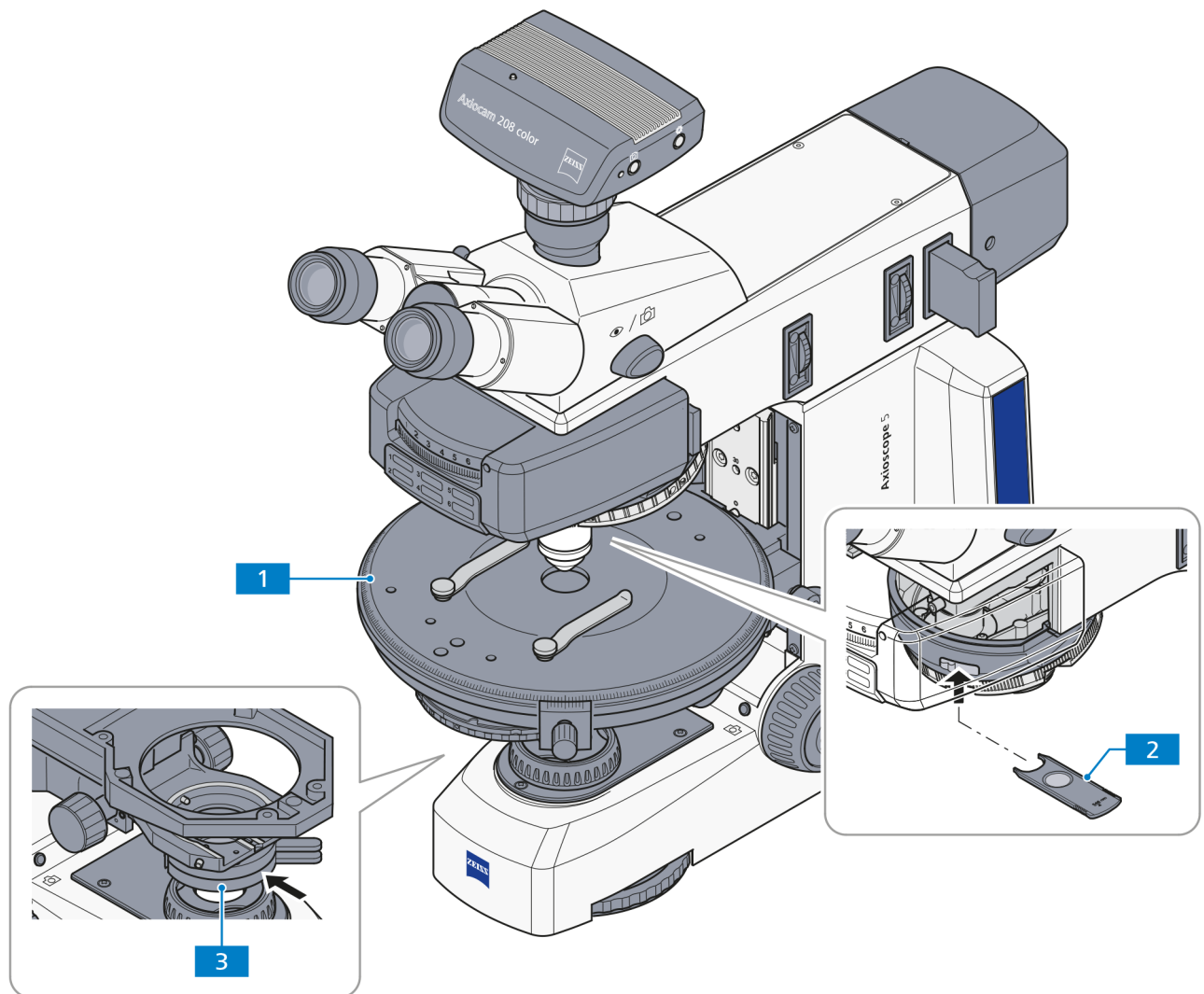

Fig. 4-9 Components for transmitted light polarization



NOTE

If an analyzer slider is going to be used for working with the Axioscope, either the reflector module H P&C or an empty position must be swiveled in on the reflector turret/slider.

- Bring the specimen to be examined into the field of view and turn it with the rotary stage. Normally, birefringent (anisotropic) objects will now show the same color and intensity variations as described above during rotation between crossed polarizers. Optically anisotropic substances may remain dark when an isotropic direction, e.g. from optically single-axle or double-axle crystals, is placed parallel to the observation direction.

4.2.6.2 Determination of the polarization direction $n_{\gamma'}$

(1) Application

The determination of the polarization direction of n_{γ} or $n_{\gamma'}$ respectively (polarization direction with the absolute or relative largest index of refraction) and n_{α} or $n_{\alpha'}$ respectively (polarization direction with the absolute or relative smallest index of refraction) relative to the morphological directions, e.g. of crystal surfaces, crystal needles or fibers, provide an important signature of the material. This method is also used in the diagnosis of bio-crystals (e.g. gout and pseudo-gout).

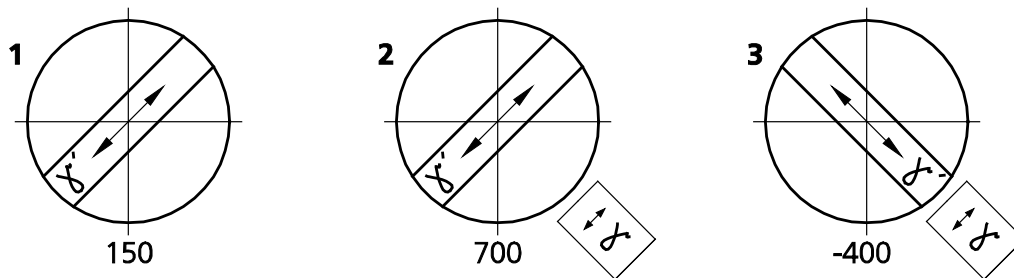

Fig. 4-10 Determination of the polarization direction $n_{\gamma'}$ in a synthetic fiber

(2) Instrumentation

- Eyepiece with reticle
- Strain-free objectives
- Rotary stage (Fig. 4-9/1)
- D polarizer (rotatable or fixed), if not using a condenser with an integrated polarizer
- ACR P&C analyzer module for transmitted light in the reflector turret/slider or analyzer slider D fixed or with lambda plate
- Pol adjusting tool sample for polarization microscopy (453679-0000-000)

(3) Setting the microscope

- Adjust the microscope as described in section 4.2.1 (3) for transmitted light brightfield microscopy. Make sure the inter-pupillary distance is adjusted correctly on the binocular tube (see section 4.1.1).
- Center the rotary stage Pol (Fig. 4-9/1) and objectives (see sections 3.1.10.5 and 3.1.10.6).
- Swivel the polarizer (Fig. 4-9/3) into the beam path and position it to 0° if you are using a rotatable polarizer.
- Swivel in the analyzer module on the reflector turret (Fig. 4-9/2) (or insert the analyzer slider into the intermediate plate). Because of the crossed polarizers the field of view now appears dark.
- Place the Pol adjusting tool sample on the microscope stage and turn until the sample appears dark.
- Remove the analyzer from the beam path and align the reticle along the split cracks of the sample.

- Now insert the analyzer back into the beam path and remove the adjustment sample. The forward direction of the polarizer and analyzer is now parallel to the cross hair in the reticle (polarizer east-west, analyzer north-south).
- Turn the Pol rotary stage with the sample, e.g. a synthetic fiber, so that the sample reaches maximal darkness. The fiber is now parallel to one of the two lines in the cross hair orientation. If the deflection is significant (5° and more) you will need to recalibrate your microscope for polarization.

**NOTE**

Do not change the eyepiece distance on the binocular tube any further to avoid shifting the angular position of the reticle to the fiber.

- Now turn the stage by approx. 45° until the longitudinal axis of the fiber is pointing in northeast-southwest direction (Fig. 4-11). The sample now shows the strongest brightness (diagonal position). The sample can have any color in this position.
- Slide in the λ compensator.

Like the sample, the λ compensator is a birefringent object, but it has a defined path difference of 550 nm and a maximum oscillation direction n_γ pointing strongly to NE-SW.

When the compensator λ is put in, the sample changes its color depending on its orientation (NE-SW or NW-SE).

The changes in color are based on optical interference. It is necessary to compare the interference colors (path differences) in both diagonal positions (NE-SW and NW-SE).

The path difference results from the interference of the polarization of the sample and the polarization of the λ compensator.

The largest path difference occurs when the polarization direction of the sample or the absolute or relative largest index of refraction (n_γ or n_γ') is parallel to the largest polarization direction of the λ compensator. The sample appears then e.g. in blue-green (Fig. 4-10/2).

The smallest path difference occurs when the direction of polarization of the sample with the absolute or relative smallest index of refraction (n_α or n_α') is perpendicular to the polarization direction of the compensator λ . The sample then appears e.g. yellow (Fig. 4-10/3).

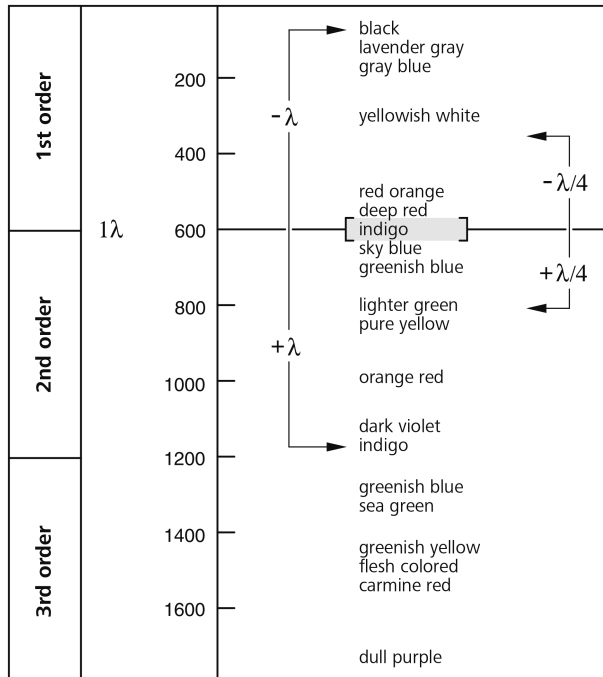

Fig. 4-11 Diagram of the Michel-Lévy color tables

(4) Conclusions

According to the Michel-Lévy color table (Fig. 4-11), the gray-white color which occurs in the bright position as discussed in the example above (Fig. 4-10/1) corresponds to a path difference of 150 nm.

After insertion of the λ compensator the surroundings of the artificial fiber which is not birefringent show a bright red which corresponds to a path difference of the compensator of 550 nm (the first order interference color for the path difference of 550 nm corresponds to 1λ).

If the polarization direction of the birefringence sample to be investigated is parallel to the largest polarization direction of the compensator λ , i.e. in the NE-SW direction, the path difference of the sample (i.e. gray-white: 150 nm) and the path difference of the λ compensator (red: 550 nm) add up. This leads to a change in color of the sample from gray-white to blue-green (resulting path difference = 700 nm).

If the polarization direction of the birefringence sample to be investigated is perpendicular to the largest polarization direction of the λ compensator, i.e. in the NW-SE direction, the path difference of the sample (e.g. gray-white: 150 nm) is subtracted from the path difference of the λ compensator (red: 550 nm). This leads to a change in color of the sample from gray-white to orange (resulting path difference = 400 nm).



NOTE

Michel-Lévy color tables can be ordered under literature catalog no. 42-312.

4.2.6.3 Measuring path differences

Measuring compensators are required for the accurate measurement of path differences,. These compensators reset, i.e. compensate the path difference produced by the specimen to zero (first order black).

While the addition position as well as the subtraction position are of interest for the methods described above, **only** the subtraction position is relevant for measurements.

Path differences in the specimen can assume very small values ($1/50 \lambda$ or 10 nm) and very large values (greater than 10λ or approx. 5500 nm and more) and thus determine the compensator appropriate for the measurement.

To find the appropriate compensator, proceed as follows:

- Set the microscope as for transmitted light brightfield microscopy (see also section 4.2.1), taking particular care to set the inter-pupillary distance correctly on the binocular tube (see also section 3.1.4).
- Position the specimen feature to be examined directly above the center of the reticle.
- Restrict the size of the aperture to a value of about 0.2.
- Rotate the Pol rotary stage until the specimen is in extinction position, i.e. it appears **entirely dark**. In this position, activate the 45° click stop.
- Rotate the stage **once** (by 45°), so that the specimen is in diagonal position (sample becomes bright).

The intensity of the interference or color produced by the specimen allows the following conclusion to be drawn:

- If more or less strong interference colors appear on the object, the path difference ranges approximately between $1/2 \lambda$ and about 5λ .

The suitable compensator is:

Tilting compensator B 0-5 λ (accessory 000000-1115-700).

- If the object-side color changes from light gray/white to a strong interference color, when a λ compensator (473704-0000-000) is inserted in the compensator slot, the path difference is ($1/4 \dots 1/2$) λ .



NOTE

The occurrence of the color change effect may require the assessment of two specimen positions lying 90° apart. For this purpose, rotate the centered stage (by 2 click stops).

The suitable compensator is:

Tilting compensator B 0-5 λ (accessory 000000-1115-700).

- After insertion of the λ compensator and rotation of the specimen by 90° (2 click stops), the interference color remains to be white, in this case, however, it is a "higher-order white" and thus the path difference is $> 5 \lambda$.

The compensator appropriate for this application:

Tilting compensator K 0-30 λ (accessory 000000-1115-698).

- A dark gray appearing as the interference color suggests very small path differences ($\lambda/10$ or 54.6 nm).

The compensator appropriate for this application:

Rotary compensator Brace-Köhler $\lambda/10$ (Accessory 000000-1115-703).

- Push the compensator into the slot as far as it will go.

For measurement preparation and measurement procedure, use the enclosed operating instructions.

4.2.6.4 Circular polarization contrast

(1) Application

Unlike standard polarization contrast, circular polarization contrast does not show any dark (extinction) positions that depend on the angle of rotation (azimuth) of the specimen relative to polarizer or analyzer. This means that, while you are rotating the stage, the image will always look the same, as there are no bright and dark positions. With optical anisotropy all transparent specimens show the interference colors that are characteristic to them.

(2) Microscope configuration

- Strain-free objectives
- Pol rotary stage
- DF circular polarizer (no polarizers may be mounted on the condenser), including the corresponding $\lambda/4$ plate
- analyzer slider or D analyzer module in the reflector turret

(3) Setting the microscope

- Set the microscope as for transmitted light brightfield microscopy using the KÖHLER method (see also section 4.2.1).
- Center the Pol rotary stage and objectives (if not yet done - see sections 3.1.10 and 3.1.10.6).
- For the further settings, **do not** use a specimen for the time being.
- Place the analyzer in position.
- Swivel the lower part of the D circular polarizer (Fig. 4-12/3) into the light path up to the click stop and swing in the analyzer module on the reflector turret or insert the analyzer slider into the intermediate plate (if applicable). At full light intensity, assess the extinction (darkening) of the field of view without specimen.
If the extinction is not optimal, correct the vibration direction of the polarizer by slightly and carefully turning the polarizer mount using a small screwdriver (for that, use the adjusting slots (Fig. 4-12/4) on the bottom of the polarizer) until you obtain maximum extinction. Normally, however, this is not necessary because the vibration direction of the polarizer is factory-adjusted.
- Push the 6x20 mm slider with the $\lambda/4$ plate (Fig. 4-12/5) belonging to the polarizer into the compensator slot above the nosepiece as far as it will go.

- Then, swivel the top part of the D circular polarizer (Fig. 4-12/2) into the light path.
- Rotate the lever of the $\lambda/4$ plate of the D circular polarizer (Fig. 4-12/1) until obtaining maximum extinction (dark-gray field of view) (lever points 45° to the right).

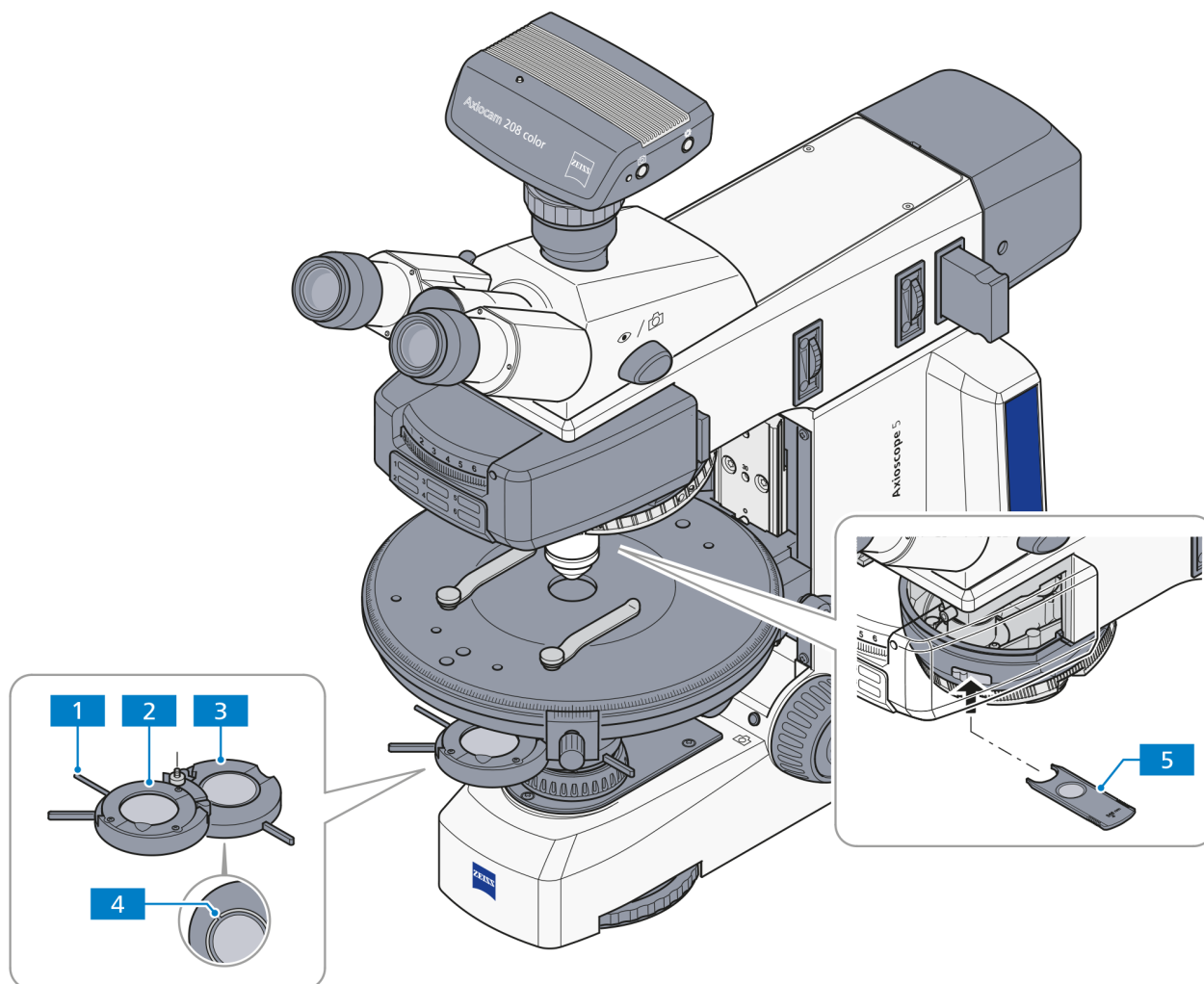

Fig. 4-12 Components for circular polarization contrast

- Do not view an anisotropic specimen unless the above adjustment has been done.
- Place the specimen to be examined on the stage.

The specimens appear constantly and independently of the stage rotation in their specific interference color, which depends on the material, specimen thickness and orientation.



NOTE

To obtain a contrast-rich image at higher objective magnifications (from approx. 20x), reduce the illumination aperture to a value of between 0.15 and 0.20, i.e. close the aperture diaphragm accordingly.

The effect of the $\lambda/4$ plate (Fig. 4-12/2) can be undone by either swiveling it out of the light path or turning it with lever (Fig. 4-12/1) into one of its two click-stop positions.

4.2.7 Setting transmitted light polarization for conoscopic observation - determining the optical character of crystals

For the classification (and thus identification) of crystalline matter, the examination of the interference image in the objective pupil delivers more valuable information than that obtained by viewing the specimen itself. The interference image becomes visible in the eyepiece if an additional optical system (fixed or focusing Bertrand lens or, in the basic version, the auxiliary microscope or diopter) is used.

In contrast to orthoscopy, this technique is called conoscopy, because here the specimen is ideally illuminated through a wide-open cone. In practical microscopic work, this means that the condenser front lens (0.9) must be in the light path, the aperture diaphragm fully open, and the objective, too, should be a high-aperture type.

4.2.7.1 Application

The determination of the optical character of transparent and weakly absorbent crystals is used to diagnose crystals. This method is also termed conoscopy.

Its main application is classical mineral microscopy. However, it also facilitates the identification and characterization of synthetic crystals, industrial minerals and plastics (e.g. films).

4.2.7.2 Simple conoscopy using the auxiliary microscope or the diopter

(1) Microscope configuration

- Recommended strain-free objectives:
 N-Achroplan 50x/0.9 Pol objective or
 EC Plan-Neofluar 40x/0.9 Pol objective
- Axioscope stand for polarization with auxiliary microscope or diopter
- Pol rotary stage
- Pol binocular photo tube
 or
 eyepiece with crossline micrometer 14:140 (454060-0000-000)
 and
 adjustment aid for polarization microscopy (453679-0000-000)
- Achromatic-aplanatic 0.9 H Pol condenser or 0.9 Pol condenser
- D polarizer (rotatable or fixed)
- analyzer slider or D analyzer module in the reflector turret or reflector slider

(2) Setting the microscope for simple conoscopy using the diopter or the auxiliary microscope

- Set the microscope as for transmitted light brightfield microscopy using the KÖHLER method (see also section 4.2.1).
- Put the specimen onto the stage and focus on it.
- Move the polarizer and the analyzer into the light path.
- If you do not use the Pol binocular photo tube, carry out the following two steps:
 - first, align the crossline micrometer 14:140 or the eyepiece reticle to the vibration direction of the polarizer using the Pol adjustment aid. Please refer to section 4.2.6.2.
 - remove the Pol adjustment aid.
- Move a selected crystal to the center of the reticle. Only crystals above a defined size can be observed.
- Swivel in the front lens on the condenser, if necessary.
- For conoscopy of small crystals, close the luminous-field diaphragm, if necessary, to prevent the axial figure of the examined crystal from being superimposed by the axial figures of adjacent crystals.
- Swivel the 40x or 50x objective into the light path and focus with the focusing drive.
- After removing an eyepiece from the tube, you can view the axial figure in the eyepiece tube.
- For an improved assessment of the axial figure, you can (if available) insert a diopter or an auxiliary microscope in the eyepiece tube.

4.2.7.3 Conoscopy with Bertrand system module**(1) Microscope configuration**

- Recommended strain-free objectives:
 - N-Achroplan 50x/0.8 Pol objective or
 - EC Plan-Neofluar 40x/0.9 Pol objective
- Axioscope stand for polarization with the Pol P&C Bertrand system module
- Pol rotary stage
- Pol binocular photo tube
or
eyepiece with crossline micrometer 14:140 (454060-0000-000)
and
adjustment aid for polarization microscopy (453679-0000-000)
- Achromatic-aplanatic 0.9 BF Pol condenser or 0.9 Pol condenser
- Bertrand system module in reflector turret
- D polarizer (rotatable or fixed)

(2) Setting the microscope for conoscopy using the Bertrand system module

- Set the microscope as for transmitted light brightfield microscopy using the KÖHLER method (see also section 4.2.1).
- Put the specimen onto the stage and focus on it.
- Move the polarizer into the light path.
- If you do not use the Pol binocular photo tube, carry out the next two steps:
 - Align the crossline micrometer 14:140 or the eyepiece reticle to the vibration direction of the polarizer using the Pol adjustment tool. Please refer to section 4.2.6.2.



NOTE

If you do not use the Pol binocular photo tube for your work, you must realign the crossline micrometer or eyepiece reticle after changing the inter-pupillary distance on the binocular tube.

- Remove the Pol adjustment tool.
 - Put the specimen onto the stage and focus on it.
- In the case of uniaxial crystals, the most favorable orientation for conoscopic viewing is obtained with those specimen features (e.g. of a thin section) that in orthoscopic viewing change the brightness as little as possible upon rotating the stage. In this case, the direction of viewing and the optical axis are \pm parallel. The same refers also to biaxial crystals, if they are viewed along or approximately in the direction of one of the two optical axes.
- Move a selected crystal to the center of the reticle.
 - Swivel the front lens on the condenser into the light path.
 - Swivel in the N-Achroplan 50x/0.8 Pol objective or the EC EPN 40x/0.9 Pol objective and focus with the focusing drive.
 - Close the luminous-field diaphragm as much as is necessary to prevent the axial figure from being superimposed by the axial figures of adjacent crystals. The smallest crystal extension that can be masked out is 4 μm .
 - Swivel in the Pol Bertrand system module on the reflector turret. Afterwards, the axial figure appears in the field of view.

4.2.7.4 Conoscopy with intermediate plate and Bertrand lens slider

(1) Microscope configuration

- Recommended strain-free, high-quality objectives:
 - EC Plan-Neofluar 40x/0.9 Pol objective or
 - EC Plan-Neofluar 100x/1.30 Oil Pol objective or
 - EC Epiplan-Neofluar 50x/0.8 Pol objective or
 - EC Epiplan-Neofluar 100x/0.9 Pol objective
- Axioscope stand for polarization with intermediate plate
- Pol rotary stage
- Pol binocular photo tube
 - or
 - eyepiece with crossline micrometer 14:140 (454060-0000-000)
 - and
 - adjustment aid for polarization microscopy (453679-0000-000)
- Achromatic-aplanatic 0.9 BF Pol condenser or 0.9 Pol condenser
- Bertrand lens slider in intermediate plate
- D analyzer module in reflector turret
- D polarizer (rotatable or fixed)

(2) Setting the microscope for conoscopy using the intermediate plate and the Bertrand lens slider

- Set the microscope as for transmitted light brightfield microscopy using the KÖHLER method (see also section 4.2.1).
- Put the specimen onto the stage and focus on it.
- Move the polarizer and the D analyzer module into the light path.
- First, align the crossline micrometer 14:140 or the eyepiece reticle to the vibration direction of the polarizer using the Pol adjusting tool sample. Please refer to section 4.2.6.2.

	NOTE
	If you do not use the Pol binocular photo tube for your work, you must realign the reticle after changing the inter-pupillary distance on the binocular tube.

- Remove the Pol adjustment tool.
- Put the specimen onto the stage and focus on it.

In the case of uniaxial crystals, the most favorable orientation for conoscopic viewing is obtained with those specimen features (e.g. of a thin section) that in orthoscopic viewing change the brightness as little as possible upon rotating the stage. In this case, the direction of viewing and the optical axis are \pm parallel. The same refers also to biaxial crystals, if they are viewed along or approximately in the direction of one of the two optical axes.

- Move a selected crystal to the center of the reticle.
- Swivel the front lens on the condenser into the light path.

- Swivel in the recommended objective and focus with the focusing drive.
- Close the luminous-field diaphragm as far as necessary to prevent the axial figures of adjacent crystals from being superimposed on the axial figure. The smallest crystal extension that can be masked out is 105 μm .
- Push the Bertrand lens slider incorporated in the intermediate plate into its active position. When you have done this, the axial figure appears in the field of view.
- Focus the axial figure by rotating the lever of the Bertrand lens slider.

4.2.7.5 Evaluation

Crystalline anisotropic specimens can be classified in optically uniaxial and biaxial specimens, each with an "optically positive" or "optically negative" character.

Uniaxial crystals show a **black cross** if the optical axis runs parallel to the viewing direction. **Depending on the degree of birefringence and the specimen thickness**, concentrically arranged colored **interference fringes (the so-called isochromates)** might appear (see also Fig. 4-13, second row).

The lines of this black cross remain closed when you rotate the stage. It can be located inside or outside the imaged objective pupil, depending on the position of the section.

With **optically biaxial** crystals, the cross resolves into two **dark hyperbola branches (the so-called isogyres)** depending on **stage rotation**, which are surrounded by colored interference patterns depending on the amount of birefringence and specimen thickness (suggestive of the figure "8").

When inserting a λ compensator (473704-0000-000) or $\lambda/4$ (473714-0000-000) or a 0-4 λ wedge compensator (000000-1140-663) into the compensator slot, with the initial state of the axial figure as illustrated in Fig. 4-13, the schematically shown changes in color (blue and yellow areas) will result in the axial figure, thus allowing the differentiation in "optically positive" and "optically negative".

	Optically uniaxial		Optically biaxial		
	Positive	Negative	Positive	Negative	
λ plate (white \rightarrow blue \rightarrow yellow)					+ = Blue - = Yellow
Quartz wedge (Direction of movement when inserted)					Direction of movement Direction of movement
$\lambda/4$ plate (position of black spots)					

Fig. 4-13 Determining the optical character

If the positions of the section are less favorable, i.e. the center of the cross of optically uniaxial or the isogyre of optically biaxial specimens is outside the objective pupil, the optical character can be assessed as follows:

- If the black isogyres are **straight** and run (related to the reticle) parallel through the pupil, the specimen is **optically uniaxial**.
- If the black isogyres are **curved lines**, traveling across the pupil on a circular path, the specimen is **optically biaxial**.

**NOTE**

Axial figures can often be better represented with circular polarization. In particular, the axial angle of optically biaxial specimens (more or less the space between isogyres) can be determined more precisely and with much less ambiguity. The optical character can also be determined by inserting the λ compensator (6x20 mm) into the compensator slot.

4.3 Illumination and contrast methods in reflected light microscopy

4.3.1 Setting up reflected light brightfield microscopy using the KÖHLER method

(1) Application

Reflected light brightfield microscopy is the easiest and most commonly used optical microscopy method. It is used to examine optically opaque specimens or samples as e.g. cut material or wafers.

For an imaging result which is as true to the specimen as possible, we must not only consider the so-called direct bundled beams but the indirect ones as well, i.e. the beams which diffract and scatter on the sample details. According to ABBE, the image is truer to the specimen when the fraction of the indirect bundled beams is larger.

The cone of light emerging from the reflected light illuminator is reflected on a color-neutral beam splitter before it passes through the objective which is focused on the specimen surface (so-called condenser function). The objective collects the light reflected on the specimen and creates, with the tube lens, the microscopic intermediate image. This image can then be examined visually or documented objectively.

(2) Instrumentation

- Axioscope with pre-installed LED 10 W illuminator or optionally used with HAL 100 halogen lamp mounted at the back of the upper part of the stand
- ACR P&C brightfield reflector module for reflected light in the reflector turret
- Upper part of the stand with HAL 100/HBO 6-positions HD, DIC with aperture and field diaphragm sliders or upper part of the stand with HAL 100/HBO 6-positions HD, DIC and 2x 14x40 mm stop slider

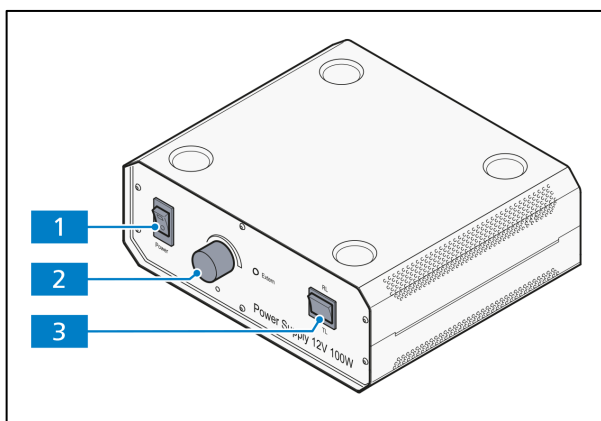

Fig. 4-14 External power supply unit for HAL 100

(3) Setting the reflected light brightfield

- The microscope is in the correct operational mode according to section 3.
- The microscope is switched on.
- When the halogen illuminator is used: Switch on the HAL 100 halogen illuminator on the external power supply unit (Fig. 4-14/1).
- Move the toggle switch (Fig. 4-14/3) to the **RL** position for reflected light.
- Adjust the light intensity with the control button on the external power supply unit (Fig. 4-14/2).
- Put a high-contrast reflected light sample on the microscope stage.
- Swing in the 10x objective on the nosepiece (Fig. 4-15/6).
- Focus the sample with the focusing drive (Fig. 4-15/5). Try to focus away from the sample to avoid any collision between the objective and sample.

- Turn the knurled button of the aperture diaphragm (Fig. 4-15/2) to a medium position (approx. half open and half closed).
- Adjust the knurled knob on the field diaphragm (Fig. 4-15/4) so that the field diaphragm becomes visible in the field of view (Fig. 4-15/A).
- Readjust the focus on the edge of the field diaphragm with the focusing drive (Fig. 4-15/B) and center the field diaphragm on the edge of the field of view (Fig. 4-15/C) with the centering screws (Fig. 4-15/3).
- Now open the field diaphragm enough to make it disappear just past the edge of the field of view (Fig. 4-15/D).
- To adjust the aperture diaphragm (image contrast), remove an eyepiece from the tube barrel and look into the barrel or mount an auxiliary microscope instead of the eyepiece.
- Center the aperture diaphragm with the centering screws (Fig. 4-15/1) and adjust the knurled knob (Fig. 4-15/2) to about 2/3 to 4/5 of the diameter of the objective exit pupil (Fig. 4-15/E) for samples with a medium contrast quality.

In most cases this position of the aperture diaphragm gives the best contrast at almost full resolution, which is the best compromise for the human eye.

- Replace the eyepiece. Re-adjust the focus using the coarse and fine focusing drives and set the image brightness according to the reflected light sample.

**NOTE**

Never use the aperture diaphragm to regulate the image brightness! Use the control knob on the external power supply unit to adjust the light intensity!

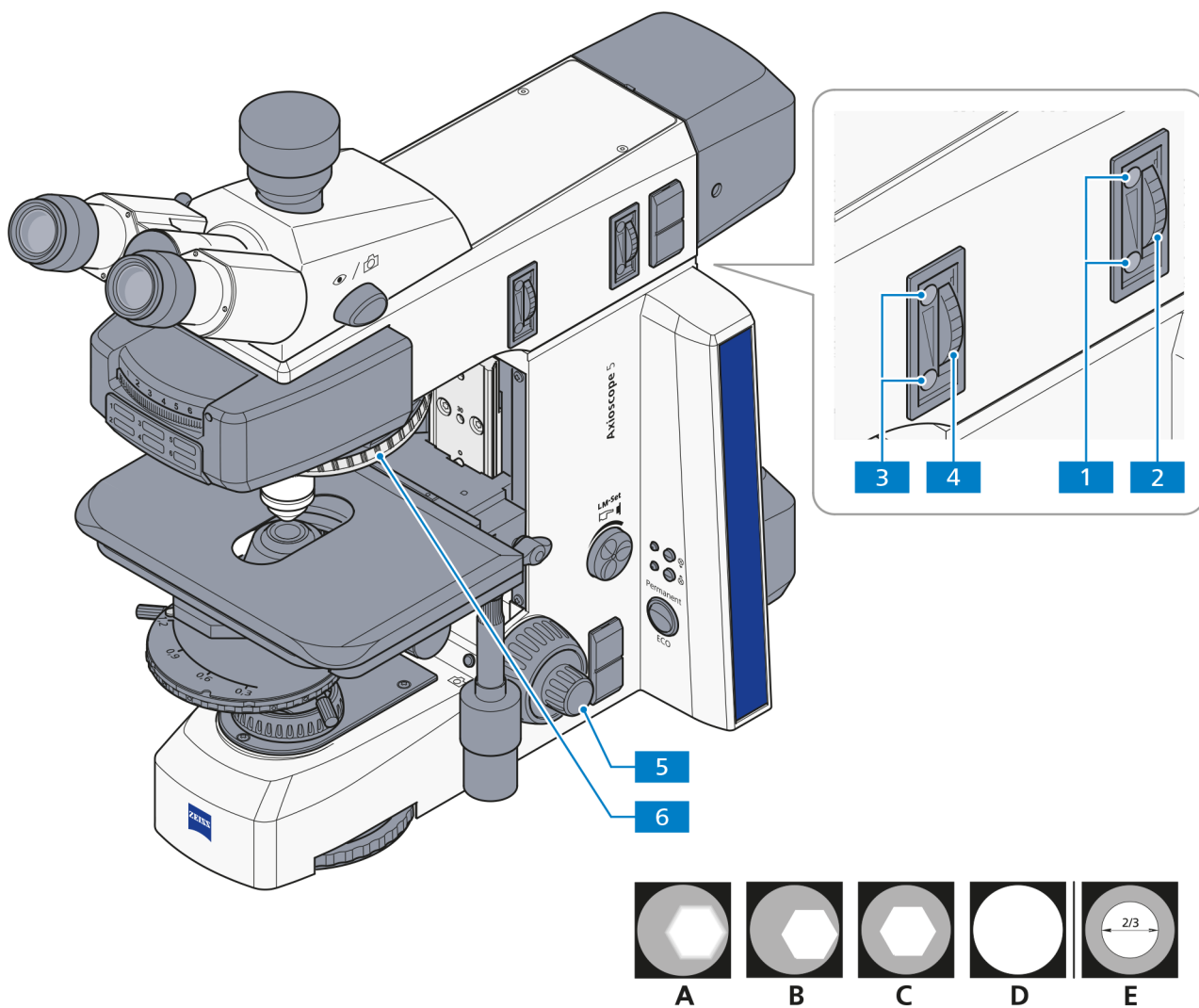

- 1 Centering screw of the aperture diaphragm
- 2 Knurled button of the aperture diaphragm
- 3 Centering screw of the field diaphragm
- 4 Knurled wheel of the field diaphragm
- 5 Focusing drive
- 6 Nosepiece

Fig. 4-15 Setting the microscope in the reflected light brightfield

4.3.2 Setting the reflected light darkfield

(1) Application

The reflected light darkfield method is applied when samples are examined which do not have areas with different reflectivity (ideal brightfield samples), but which show scratches, cracks, pores (i.e., deflections) on the plane surface. All such light-scattering details appear bright in the darkfield while the reflective plane areas remain dark.

(2) Instrumentation

- Axioscope with pre-installed LED 10 W illuminator or optionally used with the HAL 100 halogen lamp mounted at the back of the upper part of the stand
- Objectives: Epiplan-Neofluar, EC Epiplan-Neofluar, Epiplan with the additional label "HD"
- Darkfield ACR P&C reflector module for reflected light in the reflector turret/slider

(3) Setting the reflected light darkfield

- Adjust the microscope as described in section 4.3.1 for reflected light brightfield microscopy. The field diaphragm image should lie just barely outside of the edge of the field of view to avoid reflections.
- Swing the darkfield ACR P&C reflector module for reflected light on the reflector turret into the beam path.
- Remove the 6x20 mm compensator slider if mounted.
- Swing in the objective position with the darkfield objective (HD) on the nosepiece.
- If necessary, swivel in the darkfield reflector module on the reflector turret.
- Open the aperture diaphragm fully and switch off or remove neutral filters if applicable.
- Place the sample on the stage and adjust the focusing if necessary.

4.3.3 Setting reflected light DIC and reflected light C-DIC

(1) Application

The reflected light DIC and the reflected light C-DIC methods (DIC = Differential Interference Contrast; C-DIC = Differential Interference Contrast in circular polarized light) are used for the high-contrast imaging of phase objects, i.e. objects which predominantly change the phase of the light, in contrast to the amplitude objects.

(2) Instrumentation

- Axioscope with pre-installed LED 10 W illuminator or optionally used with the HAL 100 halogen lamp mounted at the back of the upper part of the stand
- Objectives: EC Epiplan-Neofluar, Epiplan with the additional label "DIC" or "Pol"
- DIC slider, fitted to the objective engraved on the top surface of the slider with amplification and aperture or 6x20 mm C-DIC slider (in connection with the DIC P&C reflector module, compensator slot 6x20 mm)

(3) Reflected light DIC, preferably for objectives Epiplan 5x to 100x and LD-Epiplan 10x to 100x

- Adjust the microscope for reflected light brightfield microscopy as described in section 4.3.1. Open the field diaphragm enough so that the edge of the diaphragm lies just barely outside of the edge of the field of view to avoid reflections.
- Swing the DIC P&C reflector module on the reflector turret/slider into the beam path.
- Swing in the objective position with the DIC position on the nosepiece.
- Slide the DIC slider into the slot of the nosepiece (above the objective).
- Place the sample on the stage, then focus and turn the mechanical stage so the structure of interest is visible with maximum contrast.
- The contrast can be optimized with the knurled button on the DIC slider.

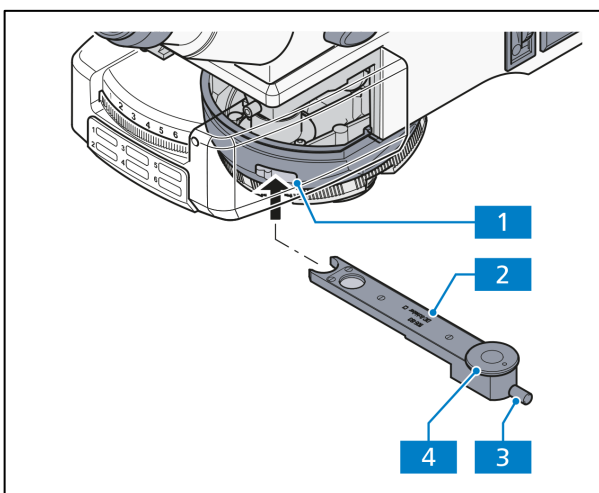

Fig. 4-16 Compensator slot 6x20 mm with C-DIC slider 6x20 mm

(4) Reflected light C-DIC

- Adjust the microscope for reflected light brightfield microscopy.
- Swing the C-DIC P&C reflector module into the beam path.
- Slide the C-DIC slider (Fig. 4-16/2) into the 6x20 mm compensator slot (Fig. 4-16/1).
- Place the sample on the stage, focus and turn the control knob (Fig. 4-16/4) on the C-DIC slider so the structure of interest is visible with maximum contrast. No further stage rotation is necessary.
- The contrast can be optimized by adjusting the control knob (Fig. 4-16/3) on the C-DIC slider.

4.3.4 Setting reflected light TIC

(1) Application

The reflected light TIC method (Micro-interferometry; TIC = Total Interference Contrast in the circular polarized light) is used in imaging and measuring specimen structures which are on hand in different azimuths.

(2) Instrumentation

- Axioscope with adjusted HAL 100 halogen illuminator mounted on the reflected light barrel
- Objectives: EC Epiplan-Neofluar, Epiplan with additional label "DIC" or "Pol"
- 6x20 mm compensator slot
- TIC slider 6x20 mm with appropriate C DIC P&C stepped reflector module

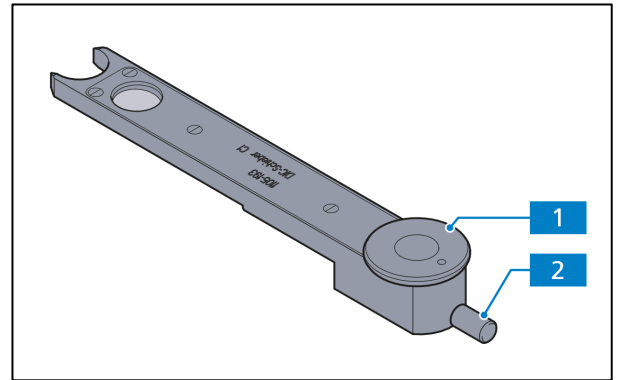

Fig. 4-17 TIC slider 6x20 mm

(3) Setting reflected light TIC

- Place the sample (e.g. a stepped object) on the stage and adjust the microscope for reflected light brightfield microscopy as described in section 4.3.1.
- Swing the C-DIC P&C reflector module on the reflector turret into the beam path.
- Slide the 6x20 mm TIC slider in the compensator slot 6x20 mm (Fig. 4-16/1). You will see chromatic interference stripes in the field of view. Using the control knob (Fig. 4-17/2) of the TIC slider, move the black interference stripe by sight to the middle of the field of view.
- To choose the structure to be measured, turn the knob (Fig. 4-17/1) on the TIC slider until the interference stripes are vertical to the direction in which the specimen is broken down (see Fig. 4-18). The interference stripes can be shifted with the aid of the control button (Fig. 4-17/2).

The step height SH is then determined with the following formula:

$$SH = \frac{n\Delta}{2} = \frac{\lambda b}{2a}$$

Where SH = step-height in nm

n = refractive index of the environment, mostly air (n = 1)

Δ = phase difference

a = distance between interference stripes

b = offset of the interference stripes along the step

λ = wave length of the illumination in nm

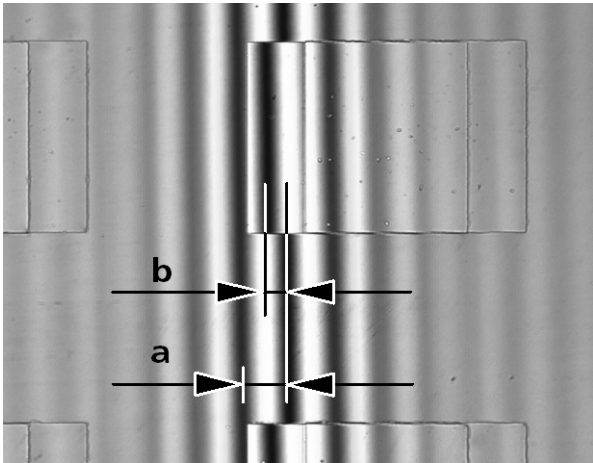

Fig. 4-18 Interference stripes

The values a and b (see Fig. 4-18) are determined with the aid of the eyepiece reticle micrometer or with the micrometer eyepiece.

If you are working with white light (without an interference filter), you must set $\lambda = 550 \text{ nm}$. When interference filters are used, it is important to apply the focal point of their wave lengths.

The measured path difference depends on the aperture and increases with the illumination aperture.

The following correction values must be considered depending on the objective used:

Objective	Correction factor k
5x/0.15	1.0057
10x/0.25	1.0161
10x/0.30	1.0236
20x/0.4	1.0436
20x/0.50 and 50x/0.75	1.0718
50x/0.60	1.1111
50x/0.75 and 100x/0.75	1.2038
50x/0.80	1.2500
50x/0.90 and 100x/0.90	1.3929
100x/0.95	1.5241

Table 1: Correction depending on aperture

Example:

$a = 11 \text{ mm}$

$b = 5 \text{ mm}$

$\lambda = 550 \text{ nm}$

objective 20x/0.50

$$SH = \frac{\lambda \cdot b \cdot k}{2a} = \frac{550 \text{ nm} \cdot 5 \text{ mm} \cdot 1.0718}{22 \text{ mm}} = 134 \text{ nm}$$

Attention:

- If the step and its surroundings are made from different materials, the phase jumps characteristic for the material must be considered. For all non-conducting materials, the phase jump is 180°, and for all semi-conductors only slightly different from 180°. Consequently, errors in the step-height determination may be neglected. However, if metals on top of glass are investigated, the results may become erroneous. The phase jumps given in table 2 were calculated for vertical light incidence and compact materials. They can serve as approximate values, since the phase jumps depend on the layer-thickness and the angle of incidence of the light. An accurate determination of the layer thickness is possible only when the complete specimen is covered with a homogeneous layer and the path differences are measured.
- If the layers and the steps are transparent, as with silicon dioxide on silicon, for example, the interference stripes can change their colors, so that the determination of the order of the interference may become problematic. This complication can be avoided if the sample is covered with a homogeneous layer.

Material	Phase jump ϕ
Copper	140.0°
Gold	142.5°
Silver	151.0°
Bismuth	151.0°
Nickel	157.0°
Iron	157.5°
Zinc	159.0°
Platinum	160.0°
Aluminum	160.0°
Tin	160.5°
Chrome	165.0°
Coal	160.0°
Graphite	165.0°
Silicon	177.0°
Glass	180.0°

Table 2: Calculated phase jumps for compact material and vertical incidence of light

For a thickness measurement (step height), half the difference of the phase jump at the respective interface must be considered:

$$SH = \frac{\Delta}{2} - \frac{\delta\phi}{2}$$

Example: extreme case of copper on glass

$\Phi_{copper} = 140^\circ$, $\Phi_{glass} = 180^\circ$, consequently, for the additional thickness due to the phase jump we obtain

$$\frac{\delta\phi}{2} = 20^\circ \text{ or } \frac{\lambda}{18} = 30 \text{ nm}$$

Without consideration of the phase jump at the respective interfaces, the thickness value would be too large by 30 nm.

4.3.5 Setting reflected light polarization – proof of bireflectance and reflection Pleochroism

(1) Application

Reflected light polarization is a contrasting method suited for cut surfaces of mineral ore, coal, ceramics, special metals and alloys. Depending on the orientation of the crystals and the specimen details, the cut surfaces often react differently when reflected in linearly polarized light.

The illumination light is polarized by the polarizer before passing through the objective onto the specimen surface where it is reflected. Then the beam parts experience path differences depending on the structure and polarization of optical rotations which, when passing through the analyzer, are represented by different shades of gray. With the aid of a compensator with a λ -plate the gray contrast can be converted into a color contrast. **Caution! Do not use a 6x20 mm compensator for this conversion!**

Even when examining "dark" specimen surfaces, a rotatable $\lambda/4$ plate in front of the objective (anti-reflective cap) helps eliminate the reflections which are inevitable when working with objectives with very low scale figures.

(2) Instrumentation

- Axioscope with pre-installed LED 10 W illuminator or optionally used with HAL 100 halogen lamp mounted at the back of the upper part of the stand
- Pol rotary stage
- Objectives: Epiplan-Neofluar Pol, EC Epiplan-Neofluar Pol, Epiplan Pol
- DIC P&C or DIC Rot I P&C reflector module in the reflector turret/slider
or Pol P&C reflector module plus analyzer slider
or analyzer slider plus polarizer slider

(3) Setting reflected light polarization

- Adjust the microscope for reflected light brightfield microscopy as described in section 4.3.1.
- If using the objective position with a DIC position, remove the DIC slider, if necessary.
- Swing the DIC P&C reflector module (Fig. 4-19/4) on the reflector turret into the beam path, swing in the Pol P&C reflector module and slide the analyzer slider into the compartment; or slide the analyzer slider (Fig. 4-19/1) and the polarizer slider (Fig. 4-19/2) into their compartments, if applicable. When using the fixed sliders, the polarizer must be aligned in the EAST-WEST direction and the analyzer in the NORTH-SOUTH direction.
- Place the sample on the stage, adjust the desired magnification, focus, and examine the sample in the polarization contrast which is now present while turning the Pol rotary stage (Fig. 4-19/3).

A sample is bireflectant when the sample details show differences in brightness and color which change when the stage rotates.

For samples with low bireflectance we recommend using the analyzer with a rotatable lambda plate.

Pleochroism is present when the color of the sample changes as soon as the stage rotates (overhead polarizer is turned on, analyzer is turned off).

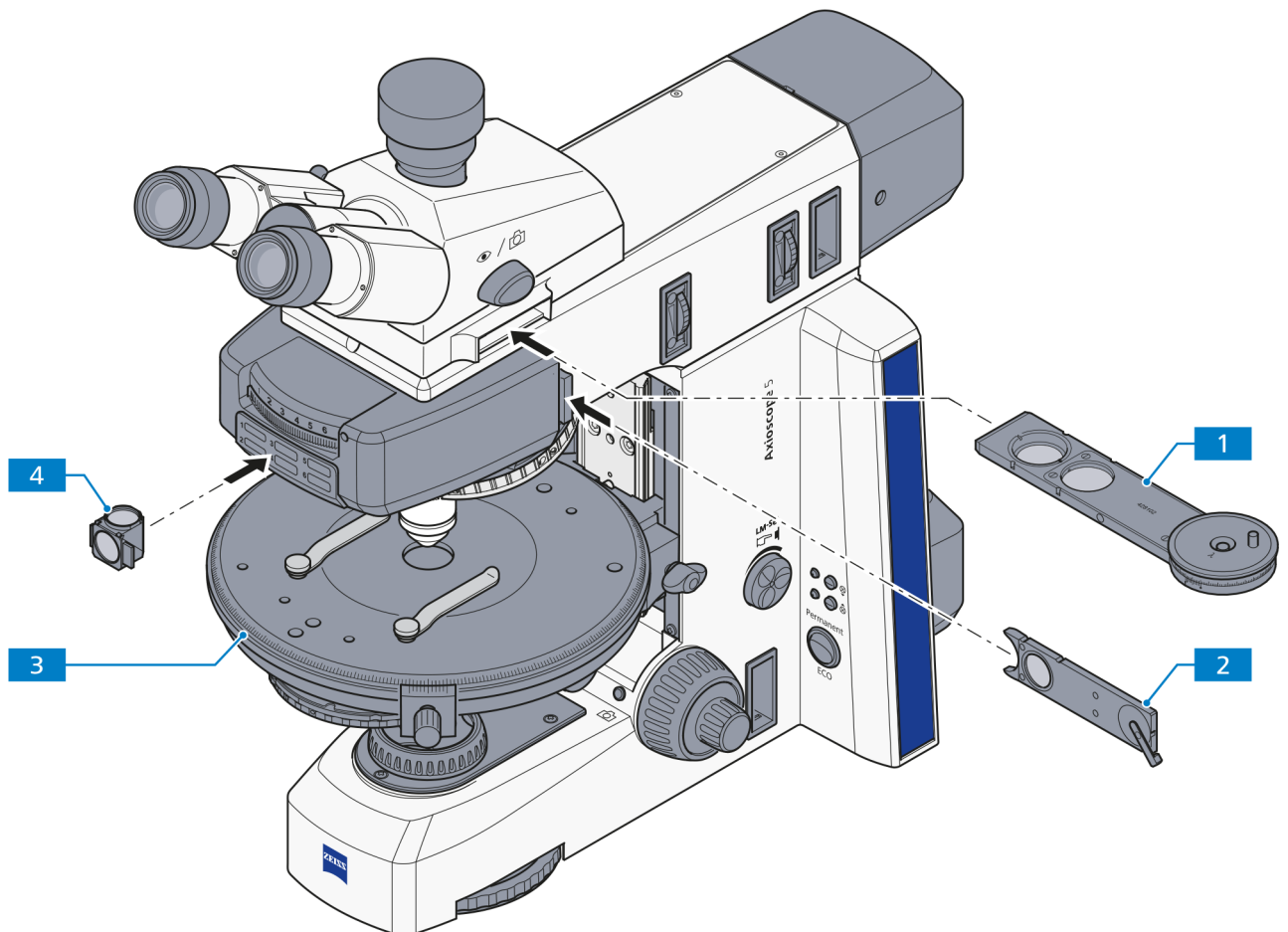

- 1 Analyzer slider TL/RL
- 2 Polarizer slider RL
- 3 Rotary stage Pol
- 4 Reflector module in the reflector turret/slider

Fig. 4-19 Components for reflected light polarization

4.3.6 Setting up reflected light fluorescence

(1) General principle of operation

The reflected light fluorescence method is used to show fluorescent substances in typical fluorescent colors in high contrast. The light originating from a high-performance illuminator in a reflected light fluorescence microscope passes through a heat protection filter onto an excitation filter (bandpass). The filtered short-wave excitation radiation is reflected by a dichroitic beam splitter and is focused on the sample through the objective. The sample absorbs the short-wave radiation before emitting longer-wave fluorescence radiation (Stokes' Law). This radiation is then captured from the image side by the objective and passes through the dichroitic beam separator. Last, the beams pass through a band-elimination filter (longpass/bandpass) and only the long-wave radiation emitted by the sample passes.

The spectra of the excitation and the band-elimination filters must match very closely. They must be inserted in a FL P&C reflector module together with the according dichroitic beam splitter.

(2) Instrumentation

- Appropriate objectives, e.g. EC Plan-Neofluar or Fluor (UV-excitation)
- FL P&C reflector module and safety shutter in the upper part (additional shutter function with the filter slider is optional)
- HBO 100 or Colibri 3 or HXP 120 illuminator for reflected light illumination
- Fluorescence protection shield



NOTE

The mercury vapor short arc lamp must be adjusted before starting the reflected light fluorescence method. Re-adjusting the adjustment might become necessary depending on the length of operating time.

(3) Setting up reflected light fluorescence

Setting the reflected light fluorescence is facilitated when starting with an objective of average degree of magnification, e.g. EC Plan-Neofluar 20x/0.50, and a sample of high fluorescence. The use of demonstration samples is also advisable for the start-up.



NOTE

If necessary, remove the λ compensator used for the transmitted light polarization method from its compartment before setting the reflected light fluorescence.

- Slide the fluorescence protection shield in the compensator slot above the nosepiece.
- Switch on the objective EC Plan-Neofluar 20x/0.50.
- Turn the condenser turret to the BF transmitted light brightfield position first (or choose phase contrast if using a PhC objective) and go to the sample detail to be examined.

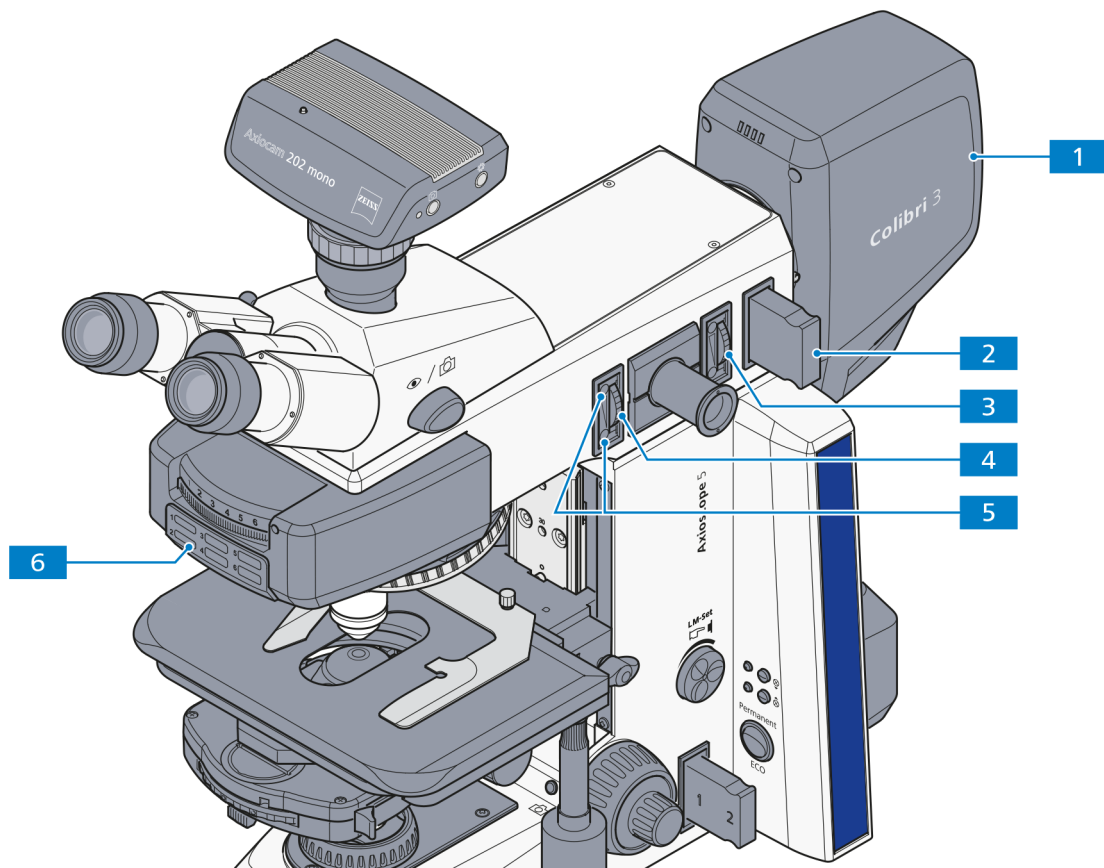

Fig. 4-20 Components for reflected light fluorescence

- Keep the light path in the reflected light illuminator blocked via the elimination position of the filter slider for reflected light (Fig. 4-20/2).
- Switch on the Colibri 3 illuminator by pushing the **RL** button (Fig. 4-20/7).
- Press the **Intensity/LM** button (Fig. 4-20/6) briefly for less than 1.5 seconds repeatedly to activate the required LED module or all LED modules of Colibri 3 together. The indicator light of the respective LED module on the Colibri 3 lights up when this module is switched on.



NOTE

If using the HBO 100 illuminator, switch on the external power supply and let it warm up to operational temperature for about 15 minutes.

- On the reflector turret/slider (Fig. 4-20/8), choose the FL P&C reflector module with the desired fluorescence filter combination (depending on the excitation mode) and switch it on.
- Now unblock the light path in the reflected light illuminator with the filter slider for reflected light (Fig. 4-20/2).
- If necessary, adjust the FL attenuator to 100% transmission in order to facilitate locating fluorescence signals. Reduce the transmission later to preserve the sample.

- Remove an eyepiece from the tube and adjust the aperture diaphragm by sight.
- Open the aperture diaphragm (Fig. 4-20/3) enough to see the whole objective exit pupil.
- Replace the eyepiece in the tube and close the field diaphragm (Fig. 4-20/4) enough to make it visible in the field of view.
- Using both centering screws (Fig. 4-20/5), center the field diaphragm on the edge of the field of view.
- Open the field diaphragm enough to make it just disappear behind the edge of the field of view, or, if you are using a sample which might bleach out, reduce the field diaphragm for the field of view.
- Focus the sample again and optimize the collector position of the HBO 100 (if used). Adjust the collector so that the reflector module of the short-wave excitation illuminates the field of view consistently. A correction of the collector position is not necessary in modules with longer-wave excitation.

5 CARE, FUSE REPLACEMENT AND SERVICE

5.1 Instrument care

Maintenance of the Axioscope is limited to the following activities:

- Turn the instrument off after each use and cover it with the appropriate protection cover (dust and humidity protection).
- Do not use or keep the instrument in a humid environment (maximum humidity $\leq 75\%$).
- Cover any open tubes with the dust protection caps.
- Remove dust or dirt from the visible optical surfaces by using a soft brush, blower brush, cotton swab, optical paper or cotton cloth.
- Remove water-soluble stains (coffee, soft drinks, etc.) with a dust free cotton cloth, which can be slightly moistened with water only or with a mild detergent diluted with water.
- Remove oil or grease stains (immersion oil, fingerprints) with a cotton swab or a dust- and lint-free free cotton cloth and the special optical cleanser L.
This cleanser is made of 90% petroleum ether by volume and 10% isopropyl alcohol (IPA) by volume. The ingredients are also known by the following names:
Petroleum ether: surgical spirit, benzine
Isopropyl alcohol: 2-propyl alcohol,
dimethylcarbinol,
2-hydroxypropane.

Clean the optical surfaces in a circular motion going from the middle towards the edge. Do not press too hard.



ATTENTION

Do not use acetone to clean the lenses of the Pol condensers.

Please comply with the following instructions if you are going to use the microscope in a hot and humid climate:

- Keep the instrument in a bright, dry and well-aired room; humidity $\leq 75\%$; especially delicate parts like objectives and eyepieces should be kept in special dry closets.

Precision optical instruments may be damaged by mold if they are kept and used under the following conditions:

- If the relative humidity $> 75\%$ longer than three days at a temperature of between $+15\text{ °C}$ and $+35\text{ °C}$.
- If they are set up in dark rooms without sufficient ventilation.
- If there are dust and finger prints on optical surfaces.

5.2 Instrument maintenance

5.2.1 Checking the instrument

- Be sure to comply with the required voltage (e.g. on the power supply unit for HBO 100).
- Check the power cable and the power plug for damage.
- As soon as you become aware of any damage, turn off the instrument and secure. Call in a qualified professional to fix the problem.
- Check to make sure that the maximum operational hours of the mercury vapor short arc lamp are not exceeded.

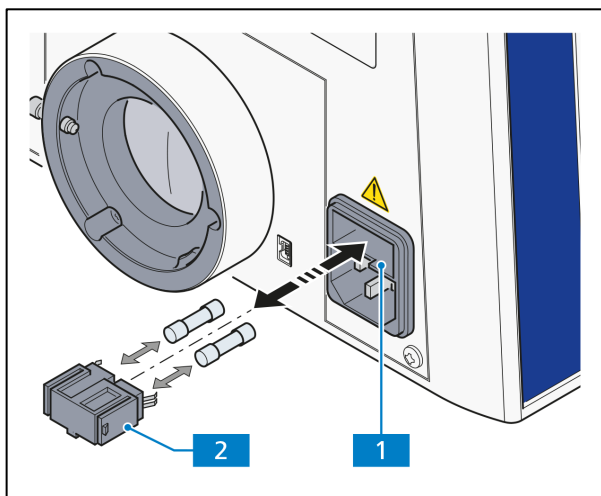

Fig. 5-1 Replacing the fuses in the stand

5.2.2 Replacing the fuses in the stand



CAUTION

Always disconnect the instrument from the power supply before changing any fuses.

If fuses blow, the cause must be identified and any technical defect must be properly eliminated.

The fuse compartment is on the back of the microscope. It is combined with the plug and contains two fuses type **T 3.15 A/H /250 V**.

- Disconnect the plug.
- Pull the fuse retainer (Fig. 5-1/2) out to the front with the aid of a small screwdriver, if necessary.
- Remove the fuses from their container and replace them with new fuses.
- Push the fuse retainer back into the compartment (Fig. 5-1/1) to the stop.
- Reconnect the instrument to the power supply.

5.2.3 Replacing the fuses in the 12 VDC 100 W power supply unit



CAUTION

Disconnect the instrument from the power supply before handling the instrument!

If fuses blow, the cause must be identified and any technical defect must be properly repaired.

The fuse compartment is on the back of the power supply unit and contains two fuses of the type **T 5 A/H 250 V, 5x20 mm**.

- Disconnect the power plug.
- Pull the fuse retainer (Fig. 5-2/2) out to the front with the aid of a small screwdriver, if necessary.
- Remove the fuses from their retainer and replace them with new fuses.
- Push the fuse retainer back into the compartment (Fig. 5-2/1) to the stop.
- Insert the power plug again.

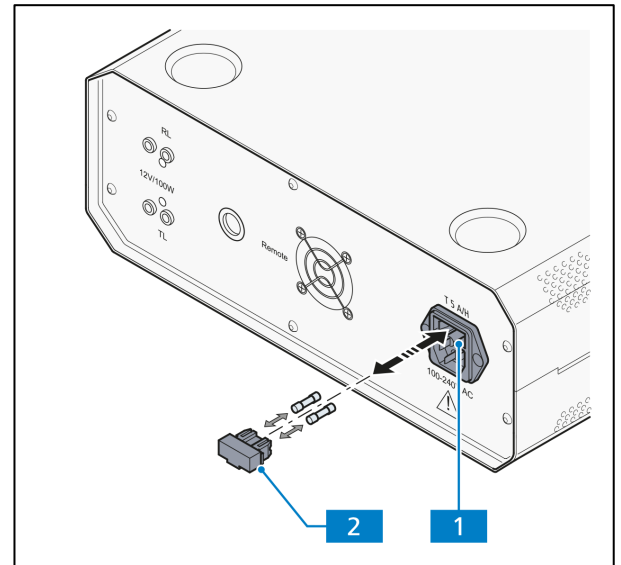

Fig. 5-2 Replacing fuses in the power supply unit

5.3 Troubleshooting**5.3.1 Microscope**

Problem	Cause	Solution
Shading or brightness irregularities in the field of view of the microscope; the field of view is not fully visible.	The vis/phot push-pull rod/shift knob on the photo tube is not in correct functional position (in-between position).	Move the vis/phot push-pull rod/shift knob to the correct functional position (end position).
	Nosepiece with objective is not fully engaged in its locking position.	Engage the nosepiece with the objective in its locking position.
	Condenser is not adjusted correctly.	Adjust the condenser correctly (adjustment, centering), see p. 87 ff.
	Aperture diaphragm is not adjusted correctly.	Adjust the aperture diaphragm correctly (centering, opening), see p. 87 ff.
	Field diaphragm is not adjusted correctly.	Adjust the field diaphragm correctly (centering, opening), see p. 87 ff.
	Filter is not correctly inserted in its slot.	Insert the filter correctly.
Low resolution and poor contrast.	Opening of the aperture diaphragm is not adjusted correctly.	Adjust the opening of the aperture diaphragm according to the 2/3-rule and the texture of the sample you are using, see p. 87 ff.
	Condenser is not focused correctly and front lens is not connected correctly.	Focus the condenser and turn the front lens correctly on or off, see p. 87 ff.
	Wrong thickness of the frame glass when using a transmitted light objective with a frame glass thickness of 0.17 mm.	Use standardized frame glasses with a thickness of 0.17 mm.
	Specimen holder is not inserted correctly.	Turn the specimen holder over, the sample side shows up.
	No immersion oil or an unspecified immersion oil is used with immersion objectives.	Use immersion oil 518 N or 518 F by ZEISS
	Air bubbles in the immersion oil.	Repeat the oiling procedure with fresh oil.
	Immersion oil on the front lens of a dry objective.	Clean the lens
	Correction setting is not set to the proper thickness of the frame glass.	Adjust the correction setting to the correct thickness of the frame glass
	Dirt or dust on the optical surfaces of objectives, eyepieces, condensers or filters.	Clean the soiled optical component

Problem	Cause	Solution
Parfocal performance not good on Axioscope 7	The focal plane was adjusted using the low-magnification nosepiece which has a larger depth of focus than the high-magnification nosepiece.	Determine the focal plane using the high- magnification nosepiece.
	There is a backlash of Z-axis drive.	Adjust the focal plane from the same direction for all the nosepieces.
No light in eyepiece	The system is in ECO mode.	Turn the Intensity/LM knob clockwise to wake up the system.
	The light intensity is too low.	Turn the Intensity/LM knob clockwise to increase the light.
	The light was turned off by another pressing of the respective RL/TL button.	Press the RL or TL button according to the corresponding indicator in green color.
	LED connector is loose (when using built-in LED10 illumination).	Unmount the LED10 lamp case from the microscope stand, unplug and re-insert the connector to the socket. Check again.
	The reflector module is incorrectly installed or absent.	Check the reflect turret and make sure the correct reflector is in use.
	The field diaphragm is closed.	Check and, if necessary, open the field diaphragm.
XY stage stops at wrong position after initialization on Axioscope 7	The XY stage initialization failed.	Restart the microscope, if the issue still exists please contact ZEISS Service.
Cannot focus on the sample under high- magnification nosepiece with Axioscope 7	The Z-axis resolution was not configured with the magnification of nosepiece.	Configure the system with correct nosepiece information with MTB Configuration.
Asymmetric image sharpness, e.g. one side is sharp, one is side blurred.	Condenser is not adjusted properly.	Re-adjust the condenser, see p. 87 ff.
	Nosepiece is not engaged in its locking position.	Engage the nosepiece in its locking position (click-diaphragm).
	Sample is not fixed on the mechanical stage.	Insert and fix the sample correctly in the specimen holder.
Distinct focus differences when changing the objective.	Focusable eyepieces are not adjusted correctly.	Adjust the focusable eyepieces according to the user's vision defect, see p. 85.
	Objective is not screwed in all the way.	Screw the objective in to the stop.
	Tube lens is not mounted, or it is mounted unnecessarily.	Mount the tube lens or remove it, according to the situation.

Problem	Cause	Solution
The left and the right field of view cannot be brought together in one image.	Distance of the eyepiece (distance of the pupils) is not adjusted correctly.	Re-adjust the distance of the eyepiece, see p. 85.
	Focusable eyepieces are not adjusted correctly.	Adjust focusable eyepieces according to the user's vision defect, see p. 85.
Using the microscope fatigues the eyes.	Distance of the eyepiece (distance of the pupils) is not adjusted correctly on the binocular tube.	Re-adjust the distance of the eyepiece, see p. 85.
	Focusable eyepieces are not properly adjusted.	Adjust the focusable eyepieces according to the user's vision defect, see p. 85.
	Image brightness is unacceptable.	Adjust the lamp voltage or insert a conversion filter.
	Binocular tube is misaligned optically, mechanically.	Call in service personnel for check-up/repair.
Dirt or dust in the field of view.	Condenser is not focused properly and front lens is not in the correct on or off mode.	Focus the condenser and turn the front lens either on or off appropriately, see p. 87 ff.
	Opening of the aperture diaphragm is too small.	Adjust the opening of the aperture diaphragm according to the 2/3-rule or according to the texture of the sample, see p. 87 ff.
	Dirt of dust on optical surfaces of objectives, eyepieces, condensers, filters or samples.	Clean the optical surfaces of the soiled components. see p. 125.
Halogen lamp 12 V, 50 W does not glow although the switch in the "On" position.	Power plug is not plugged into the outlet.	Insert the plug into the outlet. Make sure outlet and instrument are adjusted to the correct voltage.
	Halogen lamp 12 V, 50 W is not mounted.	Insert halogen lamp 12 V, 50 W, see p. 60.
	Halogen lamp 12 V, 50 W is defective.	Exchange the halogen lamp 12 V, 50 W, see p. 60.
	Fuses are defective.	Exchange the fuses, see p. 126.
	The installed electrical equipment may be defective.	Call in the service personnel to check or exchange the components, if necessary, see p. 131.
	No voltage in the power socket.	Use another power socket.

Problem	Cause	Solution
Halogen lamp 12 V, 50 W flickers, illumination intensity is not stable.	Halogen lamp 12 V, 50 W is reaching the end of its life span.	Exchange the halogen lamp 12 V, 50 W, see p. 60.
	Power cable is not installed properly or is damaged.	Install the power cable properly or exchange it.
	The pins of the halogen lamp 12 V, 50 W are not properly inserted in the socket.	Insert the pins of the halogen lamp 12 V, 50 W correctly, see p. 60.

5.4 Maintenance and repair work

Maintenance and repair work on the mechanical, optical and electronic parts inside the instrument and on the electrical equipment of the Axioscope microscopes may be performed only by the ZEISS Service Department or specially **authorized** technical personnel.

To ensure that your microscope remains in optimal and faultless working order for the longest possible time, we recommend that you conclude a service/maintenance contract with ZEISS.

If you want to place an additional order or if a maintenance/repair incident occurs, please contact your ZEISS representative.

To place a maintenance/repair call, please contact the representative responsible for your area or the main quarters at

Carl Zeiss Microscopy GmbH
Carl-Zeiss-Promenade 10
07745 Jena, Germany

microscopy@zeiss.com
www.zeiss.com/microscopy



Carl Zeiss Suzhou Co., Ltd.
Modern Industrial Square 3-B, No.333
XingPu Road SIP
215126 Suzhou, China

6 ANNEX

6.1 List of abbreviations

AC	Alternating Current
ACR	Automatic Component Recognition
AF	Width across flats
A-Plan	Achromatic objectives with improved flatness of field (ICS optical products)
B/BF	Bright field
CCD	Charge-coupled Device
CSA	Canadian Standards Association
C-DIC	Differential Interference Contrast in circular polarized light
CGT	Cover glass thickness
DF	Dark field
d	Diameter (e.g. of filters)
DC	Direct Current
DIC	Differential Interference Contrast
DIN	Deutsches Institut für Normung (German Institute for Standardization)
EC	European Community
EN	Euronorm (European Standard)
Ergo	Ergonomic/Ergonomics
FL	Fluorescence
foc.	focusable
GW	Suitable for glasses wearers
HAL	Halogen lamp (illuminator)
HBO	Mercury Vapor Short Arc Lamp for Fluorescence (illuminator)
HDMI	High Definition Multimedia Interface
ICS	Infinity Color-Corrected System
IEC	International Electrotechnical Commission
IP	Internal Protection
ISCP	Infinity Space Camera Port
ISO	International Organization for Standardization
LED	Light Emitting Diode
LM	Light Manager
n_D	Refractive Index for the D-line (sodium)
OSD	On-screen display
PCBA	Printed Circuit Board Assembly
phot	photographic

Ph/PhC	Phase Contrast
PL	Plan
PlasDIC	Differential Interference Contrast for Plastic Receptacles
Pol	Polarization
P&C	Push&Click
R	Right-hand (coaxial knurled knob on the right-hand side of the mechanical stage)
RL	Reflected light
SLR	Single Lens Reflex
T	Slow (type of fuse)
TIC	Total Interference contrast in circular polarized light
TL	Transmitted light
UL	Underwriter Laboratories
UV	Ultraviolet
VAC	Volt AC
vis	visual

6.2 Index

	Page
A	
Adjustment tool	21, 24
Ametropia.....	86
Analyzer.....	72, 95, 97, 98, 100, 101, 104
Analyzer module	98
Analyzer slider.....	72, 98
Aperture diaphragm	24, 26, 28, 30, 32, 39, 88
Axioscope 5 stand, Bio-TL.....	22
Axioscope 5 stand, Bio-TL/RL	24
Axioscope 5 stand, Mat-TL/RL	28
Axioscope 5 stand, Pol-TL/RL.....	26
Axioscope 5 Vario material stand	32, 43
Axioscope 7 stand, Mat-TL/RL mot.	30
B	
Base plate	32
Bertrand lens.....	106
Bertrand lens slider.....	109
Bertrand system	107
Bertrand system module	107
Binocular photo tube.....	36
Binocular tube.....	22, 24, 26, 28, 30, 32, 44
Binocular tube part.....	22, 24, 26, 28, 30, 32
Birefringence.....	98
Brightfield.....	87, 112
C	
Care	125
C-DIC	116
Centering objectives.....	55
Changing diaphragm.....	79
Checking the instrument	126
Circular polarization contrast	104
Coarse adjustment	22, 24, 26, 28, 30, 32
Colibri 3.....	69, 70
Color glass carrier.....	94
Color splitter	75
Color tables	102
Components.....	36
Condenser	21, 22, 24, 26, 28, 30, 39, 57, 78, 87, 90
Condenser carrier.....	21, 22, 24, 26, 28, 30, 57
Condenser, darkfield	58
Conoscopy.....	106, 107, 108, 109
Contrast methods	87
Contrasting techniques.....	17
Controls and functional elements	21, 36
Crystals, determination of the optical character	106

D

Darkfield	90, 115
Default factory settings	84
Default setting	85
Depolarizer	98
Description of the instrument	17
Diaphragm	79, 87, 94
DIC	116
Differential Interference Contrast	95
Dimensions	18
Display elements	34
Drive length	50, 52

E

Ergo tube	37
Ergonomics	50
Eyecups	46
Eyeglass protection ring	46
Eyepiece reticle	45, 86
Eyepieces	22, 24, 26, 28, 30, 32, 44, 45

F

Field diaphragm	22, 24, 26, 28, 30, 32, 87, 94, 124
Filter	74, 80
Filter holder	76
Filter slider	123
Filter slider reflected light	21, 24, 26, 28, 30, 32
Filter slider transmitted light	21, 22, 24, 26, 28, 30
Filter wheel	21, 22, 24, 26, 28, 30, 80
Fine adjustment	22, 24, 26, 28, 30, 32
Fluorescence	122
Focusing drive	22, 24, 26, 28, 30, 32, 89
Friction adjustment	51, 52
Front lens	57, 87
Fuses	126, 127

H

Halogen illuminator HAL 100	63
Halogen lamp 12 V, 100 W	65
Halogen lamp 12 V, 50 W	60
Hand wheel for vertical adjustment	32
HBO 100 illuminator	66, 68
Height stop on the condenser carrier	89
Height stop on the focusing drive	22, 24, 26, 28, 89

I

Illumination and contrast methods	87, 112
Illuminator RL LED10 CRI90	61
Illuminator TL LED10 CRI90	61
Indicator light	22, 24, 26, 28, 30, 32
Industrial property rights	138
Instrument care	125
Instrument maintenance	126

Instrument safety	9
Intended use	17
Interface diagram	20
Intermediate plate	72
Inter-pupillary distance	85
K	
Keys.....	34
Knurled wheel for switching the reflector turret position	24, 26, 28, 30, 32
KÖHLER	87, 90, 95
L	
Light intensity	22, 24, 26, 28, 30, 32
Light Manager.....	22, 24, 26, 28, 30, 32
Light Manager function	84
Light sources.....	19
Low-power system	39, 77
M	
Magnification changer.....	73
Main switch	22, 24, 26, 28, 30
Maintenance.....	126
Mechanical stage	22, 24, 28, 38, 48, 49, 52
Mechanical stage 80x60 mot.	56
Mechanical stage mot.	30
Mercury vapor short arc lamp	123
Micro-interferometry	117
Mode switch Permanent/ECO	22, 24, 26, 28, 30, 32
Modulator disk.....	78
Mounting.....	42
N	
Nosepiece	22, 24, 26, 28, 30, 32, 38, 46, 87, 112
O	
Objectives	46, 50, 54
Operation	85
P	
P&C	47
Path difference.....	103
Phase contrast.....	93
Photo tube.....	21, 22, 24, 26, 28, 30, 32, 44
Pinhole diaphragm	44
PlasDIC contrast	97
Pol adjustment aid.....	107, 108, 109
Polarization	98, 106, 120
Polarization direction	100
Polarizer.....	26, 76, 98
Power supply	81
R	
Reflected light.....	112, 115, 116, 117, 120, 122, 123

Reflected light (RL) button.....	24, 26, 28, 30
Reflected light brightfield.....	112
Reflected light fluorescence.....	122
Reflected light illuminator.....	24, 26, 28, 30, 32, 123
Reflector insert.....	48
Reflector module.....	47
Reflector slider.....	41
Reflector turret.....	21, 24, 26, 28, 30, 32, 41
Release lever for vertical adjustment.....	32
Replacing fuses.....	126, 127
Reticle.....	45
Rotary stage.....	26
Rotary stage Pol.....	53, 98, 104
S	
Service.....	131
Snap button.....	22, 24, 26, 28, 30, 32
Specimen holder.....	38
Stage.....	21, 22, 24, 26, 28, 30
Stage carrier.....	21, 22, 24, 26, 28, 30, 32, 48, 50, 53, 54, 57, 59
Stage control button.....	30
Stand.....	21
Stand column.....	32, 43
Stand models.....	21
Stands keys.....	34
Start-up.....	42
Stop slider 14x40 mm.....	40
Switching on/off.....	81
System overview.....	138
T	
Technical data.....	18
TIC.....	117
Transmitted and reflected light stand.....	24, 26, 28, 30
Transmitted light.....	87, 90, 93, 95, 97, 98, 106
Transmitted light (TL) button.....	24, 26, 28, 30
Transmitted light illuminator.....	22, 24, 26, 28, 30
Transmitted light stand.....	22
Troubleshooting.....	128
Tube.....	21, 44
Tube lens turret.....	73
U	
Unpacking.....	42
V	
Vertical adjustment of ergo tube.....	37
Vertical adjustment on the condenser carrier.....	22, 24, 26, 28, 30
Viewing height.....	85
Voltage.....	19
W	
Warning labels.....	13

Warranty.....	16
Weight	18

6.3 Industrial property rights

The instruments, their components and the methods described in this manual are protected by the following patents:

- **US 6154282**
- **US 6392796**
- **US 6595661**
- **US 7038847**
- **EP 1359453**
- **US 7046436**
- **CN 206479707 U**

6.4 System overview

See next pages.



authorized dealer:
Pulch + Lorenz microscopy
Am Untergrün 23, D-79232 March
tel: 07665 9272-0
fax: 07665 9272-20
mail: kontakt@pulchlorenz.de
web: pulchlorenz.de

Upper stand part Axioscope 7, HAL 100/HBO, 6x HD, DIC, M27

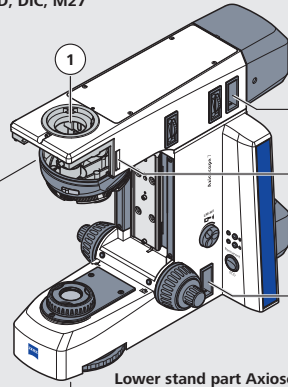

Lower stand part Axioscope 7 for LED/HAL 100 illumination

Filter slider A, 14x40 mm, 3 positions for filter diameter 25 mm
423730-9080-000

Filter slider A, 14x40 mm, 2 positions for filter diameter 25 mm
428307-9000-000

Polarizer slider A, 6x30 mm, 90° rotatable
427710-9000-000

Upper stand part Axioscope 5, FL-LED, 6x BF/6x DIC encod.

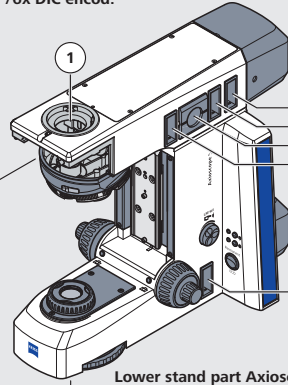

Lower stand part Axioscope 5 for LED/HAL 100 illumination

Stop slider A, 14x40 mm, with aperture stop usable
423730-9151-000

Slider, 14x40 mm, FL attenuator, discrete
423730-9130-000

Adjusting tool for HBO/XBO
423730-9120-000

Stop slider A, 14x40 mm, usable with luminous-field diaphragm
423730-9100-000

Filter slider D, 14x40 mm, 2 positions for filter diameter 36 mm
423910-9000-000

Filter diameter 36 mm (by choice see price list)

Upper stand part Axioscope 5, transmitted light, 6x H, M27

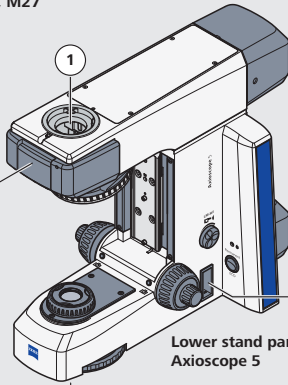

Lower stand part Axioscope 5

Filter set D
000000-1058-230

(further filter with diameter 36 mm on request)

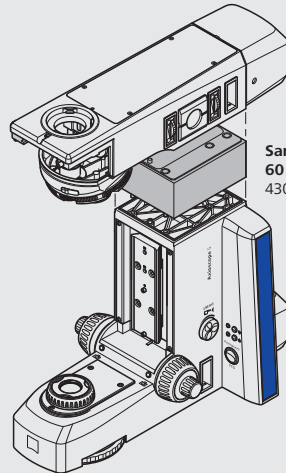

Sample space extension 60 mm
430030-9111-000

Reflector slider, 2x encoded, changeable, for P&C modules
424940-9051-000

Reflector turret, 4x encoded, changeable, for P&C modules
424940-9061-000

Reflector turret, 6x encoded, changeable, for P&C modules
424940-9001-000

Axiocam 202 mono
426570-9010-000
Axiocam 208 color
426570-9000-000
(other Axiocam on request)



Adapter Video 60 C 1/3" 0.4x
456108-0000-000
Camera Adapter 60N-C 2/3" 0.5x
426112-0000-000
Camera Adapter 60N-C 2/3" 0.63x
426113-0000-000
Camera Adapter 60N-C 1" 1.0x
426114-0000-000

Camera Adapter T2-C 1" 1.0x
426104-0000-000
Camera Adapter T2-C 1" 1.0x, adjustable
426105-0000-000

T2 Adapter for SLR camera (on request)

Camera Adapter T2-T2 DSLR 1.6x
426115-0000-000
Camera Adapter T2-T2 SLR 2.5x
426116-0000-000

Adapter 60N-T2 1.0x
426103-0000-000

Magnification changer 4x, switchable 60N-60N for module 1x
426137-9000-000

Module 0.5x
426137-9010-000
Module 1.6x
426137-9020-000
Module 2.5x
426137-9030-000
Module 4.0x
426137-9040-000
Module 5.0x
426137-9050-000

Double adapter 60N - 2x 60N 1,0x
426141-9902-000

Slider with 100% mirror
426141-9011-000

Slider with beam splitter
426141-9021-000

Camera Adapter for interface 60 e.g. Adapter Video 60 C 1/3" 0.4x
456108-0000-000

Eyepiece PL 10x/23, GW, foc.
444036-9000-000
Eyepiece E-PL 10x/23, GW, foc.
444235-9901-000
Auxiliary microscope, d=30
444830-9902-000
Pinhole diaphragm, d=30 mm
444020-0000-000

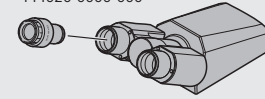

Binocular Ergophototube 20°/23 (100:0/0:100), reversed image variable, continuous vertical adjustment 44 mm
425512-0000-000

Binocular Ergophototube 20°/23 MAT (100:0/0:100), upright image variable, continuous vertical adjustment 44 mm
425514-0000-000
(not usable with: Multidiscussion equipment or Intermediate plate for analyzer slider 12x46
425313-9020-000)

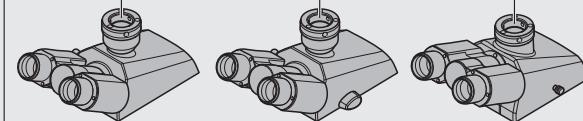

Binocular Ergophototube 15°/23 (50:50), vertically adjustable and extendable, upright image
425520-9050-000

Binocular phototube Pol 20°/23 (100:0/0:100), upright image
425520-9100-000

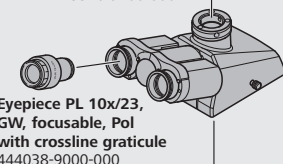

Binocular tube 30°/23, reversed image
425520-9000-000
Binocular tube 30°/23, upright image
425520-9090-000

Binocular phototube 30°/23 (50:50), reversed image
425520-9010-000

Binocular phototube 30°/23 (100:0/0:100), reversed image
425520-9020-000

Binocular phototube 20°/23 (100:0/0:100), upright image
425520-9030-000

Quartz depolarizer with tube lens
428106-9000-000
(in combination with intermediate plate)

3-position tube-lens turret with tube lens 1x
425313-9010-000
(usable only with the tubes:
425500-0000-000
425501-0000-000
425503-9901-000
425515-0000-000
in combination with SF 23 eyepieces)

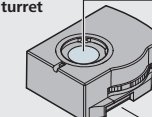

Tube lens 1.25x
425303-0000-000
Tube lens 1.6x
425304-0000-000
Tube lens 2.5x
425305-0000-000
Tube lens 4.0x
425307-0000-000

Intermediate plate for analyzer slider 12x46
425313-9020-000

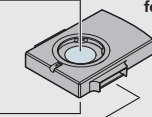

Note: Not usable with Ergotubes and Ergophototubes with vertical adjustment

Analyzer slider D/A with lambda plate, rotatable 360°
428102-0000-000
Analyzer slider D/A, 360° rotatable
428103-0000-000

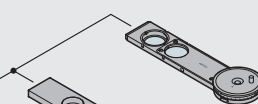

Analyzer slider D/A, fixed
428101-0000-000

Analyzer slider D/A with lambda-plate, each rotatable +/- 10°
453663-9901-000

Slider 12x46, with focusing Bertrand lens for phase contrast and conoscopy
453671-0000-000

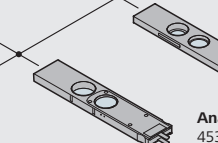

Mounting frame for two specimen sliders 76x26
432318-9000-000

Specimen holder for reflected light
432302-9000-000

Specimen holder for dual slides 76x26
432333-9001-000

Further specimen holders
(see price list 40.04.04)

Attachable object guide Pol, 28x48
453561-9901-000

Ultra condenser 1.2/1.4 (0.75-1.0)
465500-0000-000

Dry darkfield condenser 0.8/0.95 (0.6/0.75)
465505-0000-000

Slit-diaphragm 2 mm for PlasDIC
426715-9000-000

Slit-diaphragm 4.5 mm for PlasDIC
426715-9010-000

Modulator disk H, D 0.65, Ph 1, 2, 3, PlasDIC for condenser 0.9/1.25
424225-9010-000

Condenser module DIC I/0.9 with polarizer
426715-9020-000

Condenser module DIC II/0.9 with polarizer
426715-9030-000

Condenser module DIC III/0.9 with polarizer
426715-9040-000

Condenser carrier with vertical adjustment on both sides
430720-9002-000

Microscope stand Axioscope 5
Options include:
430035-9032-000
430035-9061-000
430035-9121-000
430035-9201-000
430035-9261-000
430035-9291-000

or:
Microscope stand Axioscope 7
430035-9330-000

or:
Microscope stand Axioscope Vario
430035-9150-000

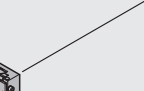
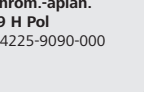
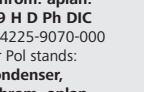
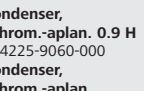
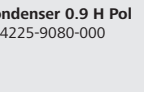
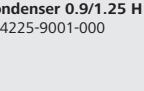
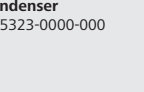
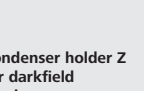
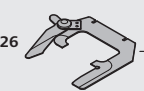
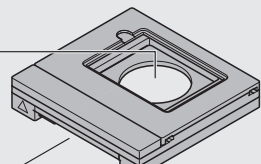

Mechanical stage, 80x60, motorized
432039-9200-000
(only for use with Axioscope 7)



Rotary stage, Pol, 360° with clickstop
432035-9131-000

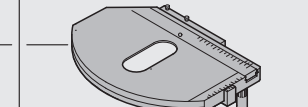

Mechanical stage 75x50/240° R with hardcoat anodized surface coaxial drive 160 mm
432035-9051-000

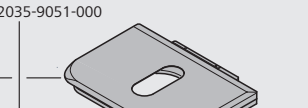

Mechanical stage 75x50 R with hardcoat anodized surface
432035-9002-000

Mechanical stage 75x50 L with hardcoat anodized surface
432035-9012-000

Mechanical stage 75x50 R, for reflected light with hardcoat anodized surface (without fig.)
453527-9903-000

Stage carrier D/A, attachable and vertically adjustable
430710-9001-000

Stage carrier D/A, attachable and vertically adjustable, rotary
430710-9011-000

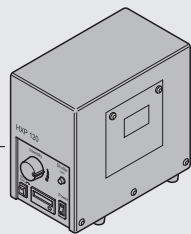
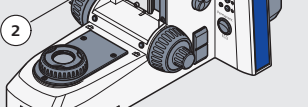
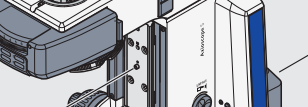

Illuminator HXP 120
423013-9010-000
Shutter remote control for HXP 120
000000-0544-644

Lightguide HXP 120 with liquid fill
000000-0482-760

Illumination adapter for light sources with light guide
423302-0000-000

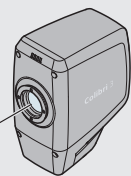

Illumination system Colibri 3
in configuration of:
423052-9505-000 for RGB-UV
423052-9440-000 for GB-UV
423052-9450-000 for GB

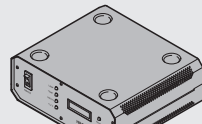
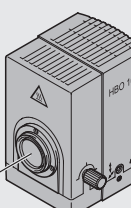

Power supply unit for HBO 100, 90...250 V, 50...60 Hz, 265 VA
432604-9902-000

HBO 100 illuminator with lamp mount and collector
423010-0000-000

HBO 100 illuminator, self-adjusting with lamp mount and collector
423011-9901-000

Note: The foot plate 000000-2202-526 is required for the HAL illuminator used for transmitted light.

Note: The HAL 100 illuminator used for reflected light cannot be used with stand 430035-9061-000.

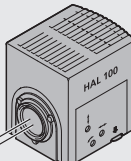

HAL 100 illuminator with quartz collector
423000-9901-000

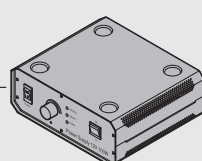

External Power supply for HAL 100 and LED lamps
432610-9060-000

For fluorescence:
FL EC ACR P&C reflector module
424933-0000-000

Filter set for FL reflector modules
(on request)

For transmitted light:
Pol ACR P&C analyzer module
424937-9901-000

Optovar modules
(on request)

For reflected light:
Brightfield ACR P&C reflector module
424928-9901-000

Darkfield ACR P&C reflector module
424922-9901-000

C-DIC/TIC ACR P&C reflector module
424941-9000-000

DIC/Pol ACR P&C reflector module
424939-9000-000

DIC/Pol red I Lambda ACR P&C reflector module
424938-0000-000

Polarizer ACR P&C reflector module
424923-9901-000

Pol ACR P&C reflector module for HBO 100
424924-9901-000

Pol P&C Bertrand system module with analyzer
424941-9040-000

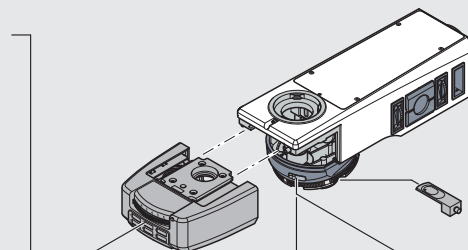

Adapter M 27x0.75 / W 0.8 H "0"
000000-1095-168

Object marker for W 0.8 objective thread
000000-1105-072
Refill set for object marker
000000-0428-327

Objectives M27

Objectives W 0.8

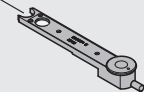

DIC slider C 6x20 for EC EPN 5x-20x/LD EC EPN 20x-50x/EC EP 5x-100x
000000-1105-192

DIC slider C 6x20 for EC EPN 50x-100x/LD EC EPN 100x
000000-1105-193

TIC slider 6x20
000000-1105-190
(usable with:
Reflector module C-DIC/TIC ACR P&C
424941-9000-000)



Analyzer slider D, fixed 6x20
433605-0000-000
Lambda compensator, 6x20
473704-0000-000
Lambda/4 compensator, 6x20
473714-0000-000

Antiglare screen
452163-0000-000

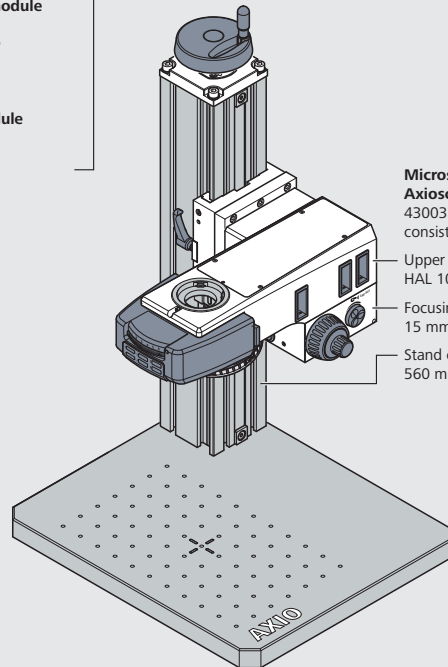

Microscope stand Axioscope Vario
430035-9150-000
consists of:

Upper stand for Axioscope, HAL 100/HBO, 6x HD DIC M27

Focusing gear box for Axioscope Vario, 15 mm focus lift

Stand column for Axioscope Vario, 560 mm

Stages with drive length < 140 mm can be used

Stage carrier, H=140 mm for Axioscope Vario base plate
451016-9902-000



Dust protection set L
434304-0000-000

Polarizer D, fixed, removable
427701-0000-000

Polarizer D, 90° rotary, removable
427706-0000-000

Polarizer, rotary, with color filter carrier
427707-0000-000

Polarizer, fixed, with lambda plate, rotary
445226-0000-000

Low-power system for 2.5x/4x objectives, for 0.9/1.25 BF condenser
424225-9050-000

Color filter carrier 3x for filter d=32 mm
428305-0000-000

Circular polarizer D, fixed, with rotary lambda/4 plate
453623-0000-000
Containing:
Slider 6x20 with lambda/4 plate

Circular polarizing equipment D ACR, with rotary lambda/4 plate
427703-9901-000
Containing:
Reflector module lambda/4 plate, ACR