

WKC. Warszawa 1976 r. Wydanie I. Nakład 4000+80 egz. Ark. wyd. 6,40. Ark.
druk. 6. Oddano do składania 7.I.76. Podpisano do druku 10.V.76. Druk ukończono
w maju 76. Zam. 553/IV/75

Grudziądzkie Zakłady Graficzne — Grudziądz, plac Wolności 5. Zam. 97

INDEX OF CONTENTS

	Page
Introduction	5
Chapter 1.	
1. Principle of operation for a polarizing interference microscope including one birefringent prism	7
2. Principle of operation for a polarizing interference microscope including two birefringent prisms	19
Chapter 2. Design features of special polarizing interference microscope components	22
Chapter 3. Preparing a microscope for normal use	28
1. Illumination Setting Procedure	32
2. Differential Method — Slit Diaphragm Condenser	33
3. Uniform Field Method Including High Image Shearing Effect	36
4. Fringe Method	37
5. Differential Method — Condenser with Compensators	38
6. Application of Polarizing Interference Objectives	39
Chapter 4. Calibration of Birefringent Prisms	40
1. Determination of the Inter-Fringe Spacing	40
2. Determination of the Constant p'	41
3. Determination of the Image Shearing Value	42
Chapter 5. Measurement of Optical path difference	42
1. Fringed field Measurement — Birefringent Prism No. 2	42
2. Uniform Colour Measurements Including high Image Shearing Effect — Birefringent Prism No. 3	47
3. Uniform Differential Field Measurements — Birefringent Prism No. 1	52
Chapter 6. Measurement of Refractive Index and Thickness	53
1. Estimation of Refractive Index Versus the Surrounding Medium	53
2. Assessment of Surface Micro-Irregularities	54
3. Measurements of the Refractive Index and Thickness Using Interference Fringe Method and the Method of Uniform Field with High Image Shearing Effect (i.e. Prisms Nos. 2 and 3)	55

	Page
4. Measurement of Refractive Index Based on the Differential Interference Method (Prism No. 1)	56
5. Measurement of Refractive Index by the Differential Interference Fringed Field Method (Prism No. 2)	60
Chapter 7. Measurement of Birefringence	62
1. Fringed Field Measurement (Prism No. 2)	62
2. Uniform Field Measurement (Prisms Nos. 1 and 3)	66
Chapter 8. Measurement of Light Transmittance	67
Chapter 9. Estimation of Dry Mass in Living Cells	70
Chapter 10. Accessories and Parts	81
Photographs of some specimens as seen through a Biolar PI microscope	
Tables	87
Bibliography	91

INTRODUCTION

An ordinary biological microscope can only be used to examine such objects which tend to vary in their light absorption versus medium that surrounds them thus showing a certain amount of natural contrast. These objects are often called amplitude objects since they result in a change of amplitude in the light being transmitted. However, the nature knows also such microobjects and structures which produce no variations in the light being absorbed and differ from the surrounding medium merely by their refractive index or thickness. These use to be called phase objects since they cause only a shift in the phase of light wave being transmitted. In a simple bench microscope, they are hardly visible or entirely invisible in the transmitted light as human eye remains insensitive to changes in the light wave phase and reacts only to variations of luminous intensity i.e. variations of the light wave amplitude (the luminous intensity being proportional to the square of amplitude).

The phase objects must be previously stained to be distinguishable by means of an ordinary biological microscope. But, the staining of specimens appears to be rather troublesome and involves a variety of undesirable consequences. In particular, the living cells and tissues are not suitable for staining as staining causes their death. Hence, whenever a normal biological microscope is being used the examination of perfectly transparent living microorganisms, which do not absorb light at all, is greatly limited.

At present, these are the phase contrast microscopes which have found almost universal use in observation of phase objects. The disadvantage of those microscopes, in addition to such drawbacks as e.g. the halo effect, low contrast in the overlapping densely arranged structures, and poor representation of extended objects relatively large in their transverse dimensions, consists in the fact that their applications have been in principle reduced to qualitative and descriptive investigations only.

The introduction of phase contrast has made it possible to assess quickly whether the refractive index of an object under examination is smaller or greater than of the surrounding medium. In certain cases it permits even an accurate assessment of such a refractive index by selection of an appropriate immersion liquid, but in principle there exist no further possibilities of quantitative investigations to be made by the

phase contrast method without taking into account the potentiality of measuring linear and two-dimensional magnitudes.

Much greater potentialities to carry out the quantitative investigations are being offered by the interference microscopy in general, and the BIOLAR PI polarizing interference microscope or a UPI polarizing interference attachment with a BIOLAR biological microscope in particular.

Polarizing interference microscopes are being used to carry on observations of various microobjects which either produce a shift in the phase (transparent) or in the amplitude (light absorbing ones) of light wave being transmitted. They also serve the purpose of measuring optical path difference (phase shift), gradient of the optical path difference thickness, refractive index, birefringence, tangential angle, microsurface irregularities, concentration of substances, content of dry mass in the cells, light transmittance and other physical quantities.

A BIOLAR PI Microscope is suitable for both qualitative and quantitative investigations being effected by the following interference methods: fringe method, differential method and uniform field method with a high image shearing effect.

The polarizing interference microscopes find numerous uses primarily in the biological and medical sciences (especially in cytology, histology, morphology, biochemistry and microbiology), being also very useful in the physical chemistry, crystallography, mineralogy, textile manufacture, in the production of thin-layer circuits and in other fields of science and technology.

CHAPTER 1

1. PRINCIPLE OF OPERATION FOR A POLARIZING INTERFERENCE MICROSCOPE INCLUDING ONE BIREFRINGENT PRISM

For optical system diagram and general principle of operation of a polarizing interference microscope refer to Fig. 1. The polarizing interference microscope differs from a conventional biological microscope basically in that it incorporates a polarizing interference system consisting of a birefringent prism W_1 , polarizer P , analyser A and a slit diaphragm D or an appropriate quartz compensator.

The birefringent prism W_1 represents a special kind of the Wollaston prism. Located just after objective Ob it can move both in the parallel as well as perpendicular directions versus the microscope centre line. Function of this prism consists basically in the splitting (bifurcating) of incident light beam into two beams viz. an ordinary and an extraordinary beam, and in producing an adequate phase shift between light beams so split. The angular bifurcation Σ of the rays of light increases along with the growing angle of refraction φ of the birefringent prism.

The polarizer P and analyser A are intended for the linear polarization of light. They are, in fact, ordinary standard polarizing filters, the so-called polaroids, which rotate about an axis being parallel to the path of light in the microscope. Polarizer P is accommodated in the microscope illuminator part underlying the condenser whereas analyser A remains between the birefringent prism and an eyepiece.

System composed of the polarizer P and analyser A , with a birefringent prism W_1 located in between, produces in the transmitted light a number of rectilinear interference fringes whose intensity reaches a maximum when the planes of polarization for both polarizer P and analyser A become mutually perpendicular or parallel and form an angle of 45° versus the refracting edge of birefringent prism W_1 (this edge adjacent to angle φ is perpendicular to the plane of Fig. 1). Fringes thus produced appear inside the prism W_1 or at a certain distance under-

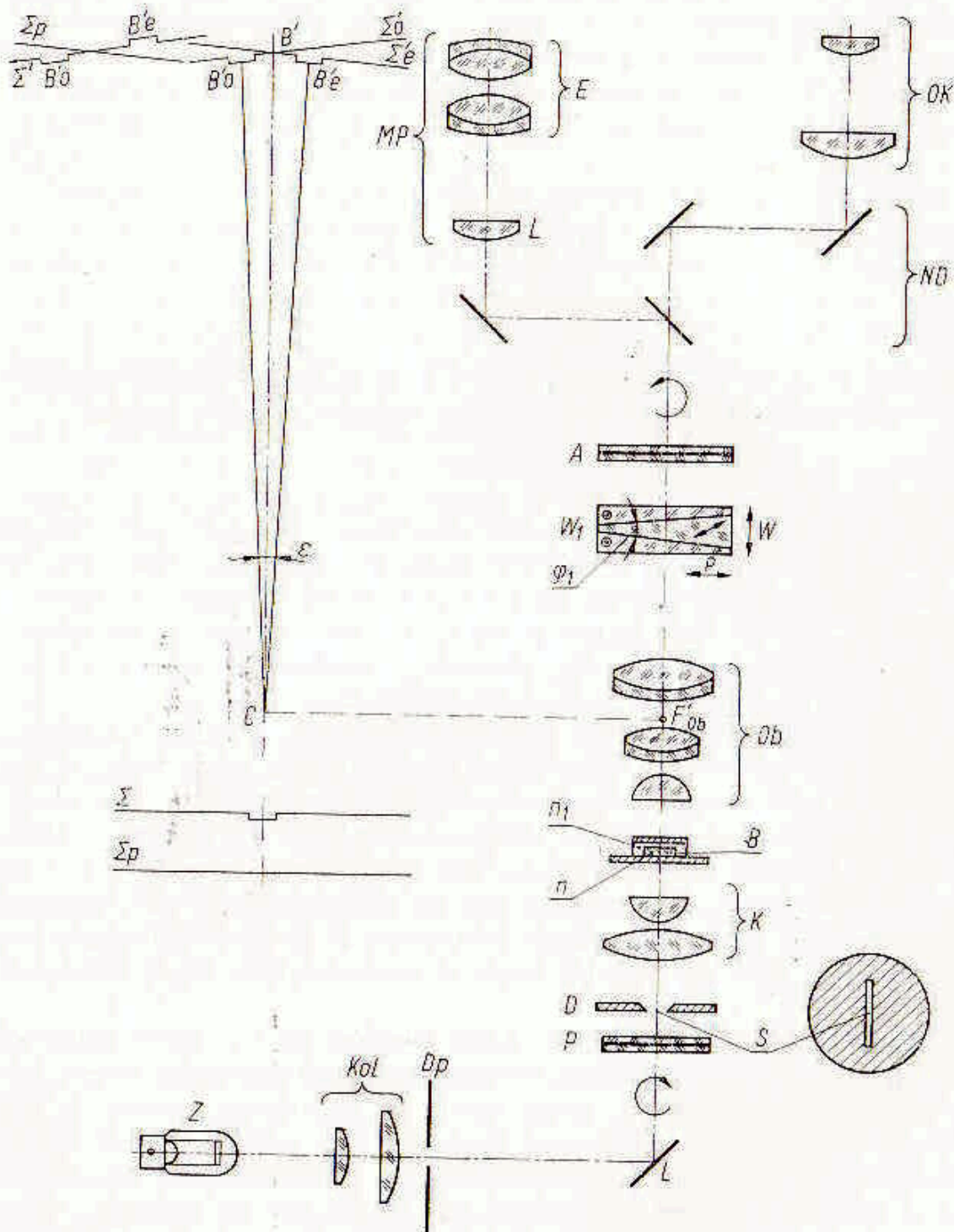

Fig. 1. Diagram illustrating optical system of a polarizing interference microscope with only one birefringent prism

Z — Source of light; Kol — Illuminator collector; DP — Field diaphragm; P — Polarizer; D — Slit diaphragm; S — Slit; K — Condenser; B — Specimen; Ob — Objective; W_1 — Birefringent prism; A — Analyser; ND — Binocular body; Ok — Eyepiece; MP — Auxiliary microscope; E — Eyepiece; L — Objective (for explanations regarding other symbols see text)

neath at points C where bifurcation of light rays usually takes place. The interfringe spacing h remains constant throughout the entire length of the prism and can be expressed as follows:

$$h = \frac{\lambda}{\varepsilon} \quad (1)$$

where λ — light wavelength.

Slit diaphragm D has been located in the focus of condenser K , the slit S being parallel to the refracting edge of birefringent prism W_1 . Slit S and the condenser K form a collimator out of which beams of coherent light are delivered susceptible to interference in the microscopic image plane. Interference fringes in this plane can be produced only if slit S has been adequately narrowed whereas interference fringes in the exit pupil of objective Ob , referred to above, can be observed no matter what the width of slit S is.

Let us assume that the phase object B (Fig. 1) under examination has the form of, say, a narrow strip having thickness t . This object is isotropic, perfectly transparent, and its refractive index n differs from that of the surrounding medium n_1 (e.g. $n > n_1$). Under such circumstances, the flat light wave Σ'_p coming out of the condenser K , after a linear polarization in the polarizer P , will be subject to a phase lag within the space occupied by object B thus taking on the form of wave Σ . This wave enters objective Ob where it becomes split by the birefringent prism W_1 into two waves, an ordinary and an extraordinary wave, polarized versus each other in perpendicular planes. The analyser A transmits only these wave components which are parallel to its own direction of light oscillation.

With the light rays allowed to pass through the analyser A two waves are produced, an ordinary wave Σ'_o and an extraordinary wave Σ'_e , linearly polarized in the planes at right angles versus each other. These waves can interfere so that after their superposition in the image plane an interference is generally obtained in the form of rectilinear interference fringes liable to deformation in the opposite directions where the ordinary, B'_o , and extraordinary, B'_e , images of object B (Fig. 2) are usually produced.

Interference image appearing in the microscope image plane can be interpreted as a superposition of flat waves Σ_p and Σ' , which are liable to a phase displacement being advanced within the image area of object under examination and delayed within the second image area respectively. This is like the observation in an ordinary interferometer

of two objects having $t(n_1 - n)$ and $-t(n_1 - n)$ optical thicknesses and separated from one another by a value r to be found from the formula:

$$r = \frac{l \cdot \varepsilon}{G} \quad (2)$$

where:

- l — distance between the point of bifurcation of light rays and the microscopic image plane ($l = CB'$);
- ε — angular bifurcation in radians;
- G — objective magnification.

Thus obtained interference image resembles this of the generally known interference patterns equal in their thickness and coming to be seen on an air wedge. The only difference consists in two sheared images being obtained for one and the same object, with interference fringes deviated in such images in the opposite directions. A situation is created advantageous in many cases since by measurement of a double deviation of fringes $2d$ (Fig. 2) a better accuracy of measurement is possible to be achieved for the optical path difference.

When the monochromatic light is applied, the interference image consists of alternate dark and bright fringes. Whenever the polarizer P and analyser A are crossed, dark fringes are formed in those places where optical path difference between the interfering waves Σ'_o and

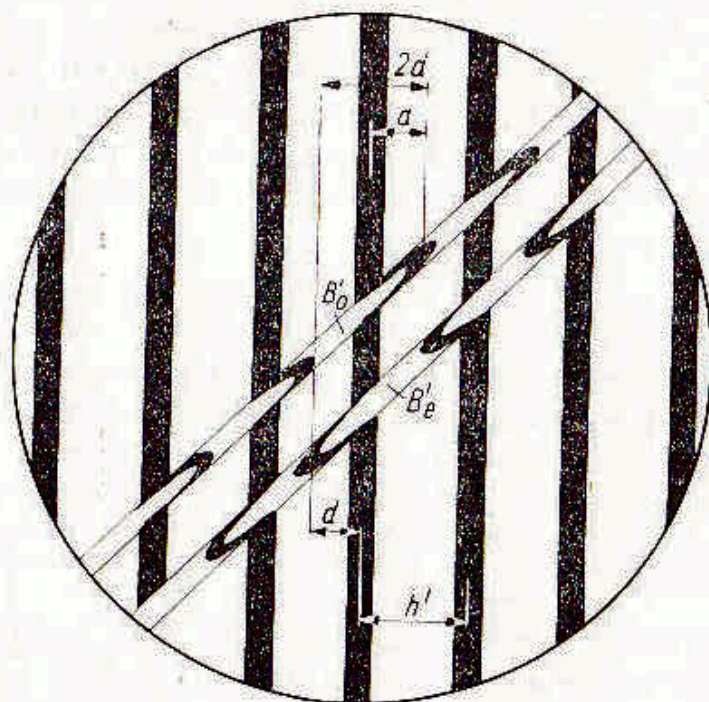

Fig. 2: Image of a narrow strip in an interference fringed field
 B'_o — Ordinary image; B'_e — Extraordinary image; h' — Inter-fringe spacing;
 d — Deviation of interference fringes

Σ'_e equals zero or a whole multiple of the wavelength λ of light having been used. However, if the polarizer and analyser are set in parallel, dark fringes appear at points where the optical path difference between those interfering waves is equal to an odd multiple of $\frac{\lambda}{2}$. When using white light, interference fringes — except for the zero fringe at crossed polarizer and analyser — are coloured whereby their intensity becomes lower and lower with the increase in interference order to finally fade away completely (Fig. 45).

The method described herein, and hereinafter called „fringe method”, appears to be particularly suitable in the examination of oblong and minor separated objects whose images can be split by half at least.

Such oblong objects include fibres, thin strips or edges and should be preferably set up so as to be at 45° versus the direction of interference fringes (Fig. 2) approximately.

By measuring the inter-fringe spacing h' and deviation of fringes d , and by knowing refractive index n_1 of the surrounding medium, one can determine refractive index n of the object under examination if only he knows its thickness t , or evaluate the thickness t if the refractive index n is known. When applying two immersion liquids of a known refractive index n_1 and n_2 respectively, it is possible to determine t and n at a time. This will be discussed in detail in Chapter 6.

The interference fringe image can be obtained in the microscope viewing plane only when the plane of interference fringes for the birefringent prism W_1 does not coincide with the focus F'_{ob} of the microscope objective Ob . When the birefringent prism is brought up nearer to the objective Ob , then the birefringent fringes do become increasingly extended until they change into wide bands so as to finally cover the entire field homogeneous in its appearance. Such a situation occurs when the point of light rays being split fully coincides with the viewing focus of the F'_{ob} objective. Then, the Σ'_o and Σ'_e wave fronts neither intersect nor are inclined versus each other, like in the fringe method described hereinabove, but they are mutually parallel (Fig. 3). The optical path difference Ψ does not change continually but remains constant now, except for the space where split images B'_o and B'_e of the object B are produced. As a consequence, background of the microscopic field of view comes to be seen as being uniform in its colour whereas the object under examination is observed as a change in said colour at the point where the split B'_o

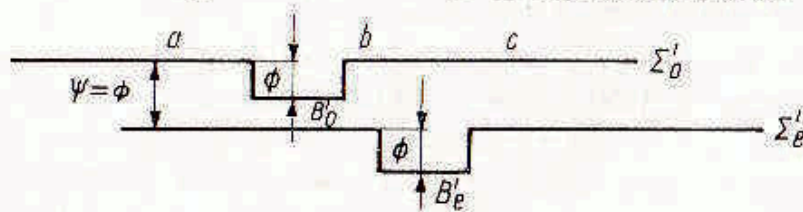

Fig. 3

and B'_e are being formed, or, as a change in the level of brightness where monochromatic light finds use. Field brightness depends in this case on the optical path difference Ψ between waves Σ'_o and Σ'_e . With the crossed polarizer and analyser, darkness of the field background will reach its maximum if the optical path difference Ψ is zero or a whole multiple of the applied light wavelength λ . For optical path difference Ψ equal to an odd multiple of $\lambda/2$ the field of view will remain, on the other hand, at its maximum brightness. Where intermediate values are involved, the level of field brightness will vary accordingly. With the polarizer and analyser set in parallel versus each other, the situation will be reversed, i.e. the minimum darkness of the field of view will be for $\Psi = \lambda(m=0, 1, 2\dots)$ and the maximum one for $\Psi = m \frac{\lambda}{2} (m=1, 3, 5\dots)$.

When the white light is being used, it will be generally the colour that shall change along with the varying optical path difference instead of brightness. For interference colours depending on the optical path difference Ψ variations, both at crossed and parallel polarizer and analyser, refer to Table I. And so e.g. a dark colour will be produced at $\Psi=0$ with the crossed polarizer and analyser; this colour will change with the growing Ψ into grey, white, and various hues of the yellow and red colour. At $\Psi=565$ nm, the so-called sensitive colour of the primary interference order comes to be seen. This is a purple colour characteristic in that it easily changes into red or violet if only the optical path difference Ψ undergoes the slightest alteration. Accordingly, a very high leap in colour will be usual for every change in the optical path difference. With the parallelly set polarizer and analyser, the sensitive colour of the primary interference order will be produced at $\Psi=280$ nm.

The value of optical path difference Ψ between the interfering waves Σ'_o and Σ'_e will depend on the point at which the beam of light will pass through the birefringent prism W_1 (Fig. 1). By shifting this prism at right angles to the microscope centre line (this direction is shown by the arrow p in Fig. 1), the operator is in a position to change the optical path difference Ψ in a continuous manner thus controlling also the level of brightness or darkness of the microscopic field and this of the image being viewed. This provides means for an adequate selection of viewing conditions under coloured interference contrast and renders possible measuring of the optical path difference Φ caused by the object under examination.

To explain this feature in a more detailed manner let us assume that the observation takes place in the white light conditions, with the birefringent prism set to the primary-order sensitive colour (i.e. with the polarizer and analyser in their crossed positions). The background of the microscopic field of view (space a, b, c in Fig. 3) will

then become purple. On the other hand, in these sections of the field of view where the ordinary image B'_o and extraordinary image B'_e of the object under examination are being formed the colour will be different since at B'_o the optical path difference Ψ between interfering waves Σ'_o and Σ'_e will be smaller and at B'_e greater by the value of optical path difference Φ caused by the object under observation (B). Accordingly, image B'_o will note optical path difference $\Psi=(560-\Phi)$ nm and image B'_e $\Psi=(560+\Phi)$ nm.

For instance, assume $\Phi=100$ nm to find that optical path difference Ψ at B'_o and B'_e will be 460 nm and 660 nm respectively.

As presented in Interference Colour Table, image B'_o will be orange and B'_e blue in their hue. For $\Psi=0$ (with both polaroids crossed), i.e. for birefringent prism set to dark colouration, both images will be identically lavender-grey in their tinge. With the birefringent prism set to another field colouration, the split images will of course take another colour too. Therefore, by setting the birefringent prism to different colourations of the field of view and by assessing change taking place in the split images of the object under observation one can easily find optical path difference Φ for such an object in respect to the surrounding medium.

This method, though being quite satisfactory in numerous applications and leading to good results, is nevertheless highly subjective. While considering this fact, a more objective method for measuring the optical path difference — also straightforward in use and ensuring good accuracy of measurement — has been introduced in the polarizing interference microscopy. This consists in producing first an initial (standard) colouration of the field background in the ordinary or extraordinary image to carry out consequently measurement of the transversal shift of the birefringent prism performed during this operation.

To achieve this, it will be preferable to make use of the dark zero-interference-order colour (with the crossed polarizer and analyser). More details about this step find in Fig. 4. The magnitude to be

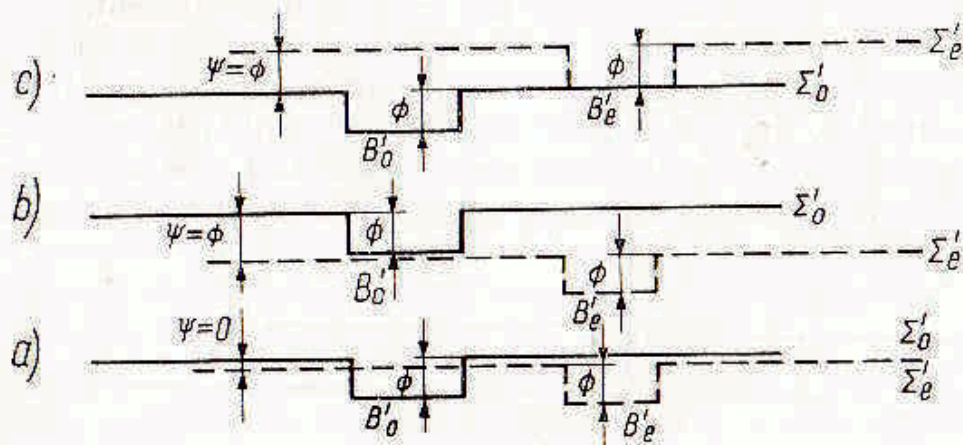

Fig. 4

measured in this case is the optical path difference Φ caused by the object under observation. Assume now that the birefringent prism has been set in the first place to the dark background of the viewing field (Fig. 4a), and that the birefringent prism position is p_0 (this is like zero position). While moving the birefringent prism transversely from this position, in either direction, wave surfaces will separate due to phase displacement so that either ordinary wave Σ'_o will be in advance of the extraordinary wave Σ'_e or the extraordinary wave Σ'_e will precede the ordinary one Σ'_o . As soon as the optical path difference Ψ between waves Σ'_o and Σ'_e reaches outside spaces B'_o and B'_e , the value of the optical path difference Φ caused by the object under examination, then either the ordinary image B'_o (Fig. 4b) or the extraordinary one B'_e (Fig. 4c) will receive a dark colouration, i.e. the former colouration of the viewing field background. Let us now assume that the maximum darkening of the ordinary or extraordinary image corresponds to position p_1 of the birefringent prism. In these circumstances, the optical path difference Φ will be:

$$\Phi = (p_1 - p_0) \Psi_p \quad (3)$$

where: Ψ_p is the optical path difference between waves Σ'_o and Σ'_e per unit of the birefringent prism transversal shift.

It can be easily proved that

$$\Psi_p = \frac{\lambda}{h} \quad (4)$$

By reading prism positions p_1 and p_2 , in which first one and then the second image of the object being observed become maximally darkened, one can find the double value of:

$$2\Phi = (p_2 - p_1) \Psi_p \quad (5)$$

contributing to an increase in the accuracy of measurement.

Where objects of a varying thickness or varying refractive index are investigated, the optical path difference Ψ within the space of doubled images remains a variable and not constant (Fig. 5). Therefore, also colour or brightness will change accordingly at various points of

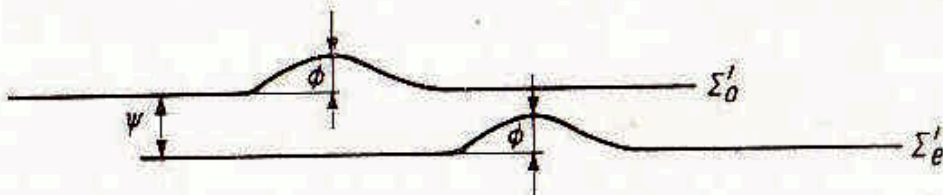

Fig. 5

the image. Considering a change in colour it will be possible to estimate variations of the optical path difference within the object, or by darkening particular sections of the image to determine optical path difference at any point of the object under examination.

So far, the case of a total splitting of both the ordinary and extraordinary images of the object under observation has been discussed. The conditions of observation, as referred to above look, however, a little different if the images remain not entirely separated but partially do superimpose each other. The difference consists in the fact that no change will be observed in the area where both images overlap each other (neither brightness of the field of view will be affected at this point) if only the investigated object remains isotropic and homogeneous regarding its optical path. Fig. 6 explains this feature. Colouring of the field-of-view background (areas a , e) and that of space c where images B'_o and B'_e interfere with each other remains identi-

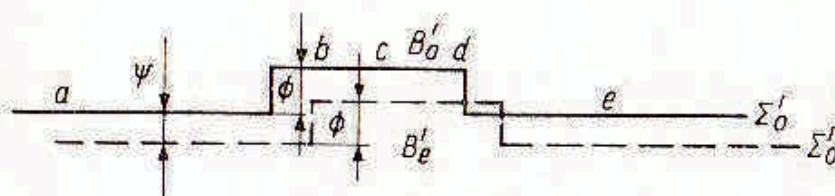

Fig. 6

cal as the optical path difference Ψ within those areas is identical as well.

Colours do change only in the areas b and d where images are doubled. The conditions within these areas remain the same as those in case of a totally doubled image, and this will only be here that the optical path difference Φ due to the object under examination will be measured.

Method discussed in the foregoing and hereinafter referred to as a *method of uniform colour with high image shearing* has been found of particular interest for observations of minor separate objects (like cells, bacteria, small microorganisms), thin layers and films being homogeneous in their character, fine crystals, etc.

A particular and the most interesting application of the uniform colour method in the polarizing interference microscopy appears to be the so-called *differential method* utilizing the fact that the transverse shearing of interfering waves becomes very small of an order of the microscope resolving power.

This method can be explained in the best way by referring it to a relatively large object showing a small gradient of the optical path difference, like e.g. a drop of liquid resting on the object slide (Fig 7a).

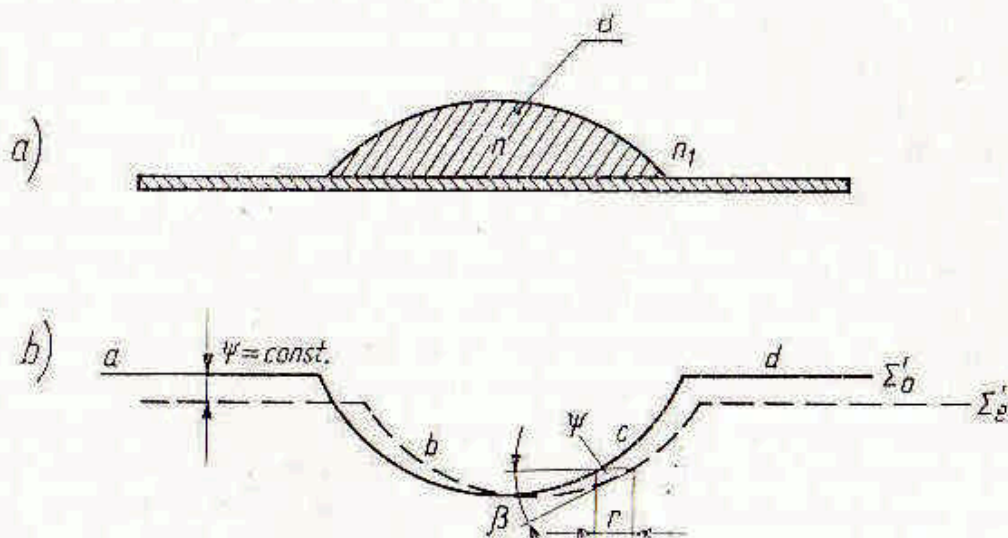

Fig. 7

Should refractive index of this object, n , exceed that of the surrounding medium, n_1 , the front surfaces of interfering waves Σ'_o and Σ'_e will be formed as shown in Fig. 7b. As will be seen, optical path difference between waves Σ'_o and Σ'_e will remain constant only outside the image of observed object in the areas a and d where a uniform colour is produced. Within the image space, the optical path difference is not constant but will vary in a continuous manner thus involving also a continuous change in the colouring of image. With a symmetrical change in the optical path difference also colours in the observed object will be subject to a symmetrical variation versus those of the background whereby image centre has the same colour as the viewing field background.

A feature of the method under consideration, which differs it from other methods discussed before, basically consists in the fact that optical path difference Ψ in the interference image does not express optical path difference Φ within the object in a direct manner, but as a gradient of this difference towards the image shearing point. To explain this phenomenon in detail it will be necessary to make use of some mathematical formulae. Let us imagine to this end a rectangular coordinate system X, Y within image area of the object B (Fig. 8a) where X -axis runs towards the image shearing point (i.e. at right angles to refracting edge of the birefringent prism W_1) while Y -axis passes through vertex H of the object B . Let us now choose any x_1 point within the image B area. Optical path difference Φ through the object B , with displacement dx on the X -axis, will now be as follows:

$$d\Phi = (n_1 - n)dy \quad (6)$$

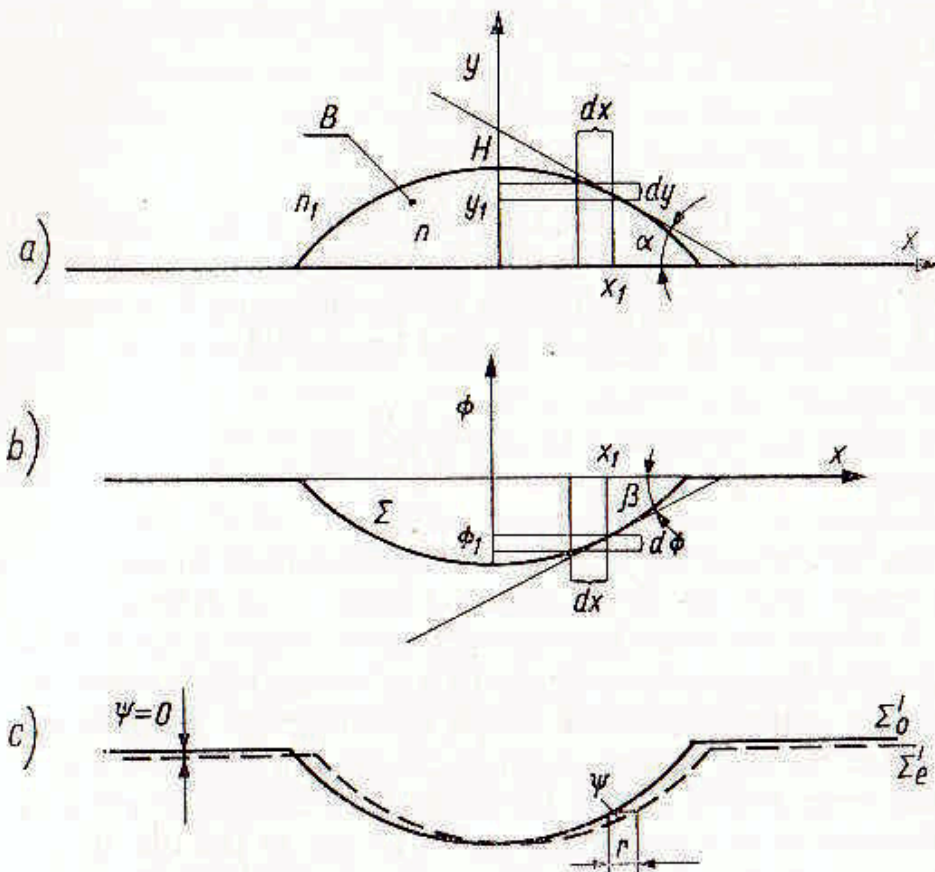

Fig. 8

As will be seen from Fig. 8a:

$$\frac{dy}{dx} = \tan \alpha \quad (7)$$

where α is an angle formed between the tangent passing through (x_1, y_1) and X-axis.

Hence:

$$d\Phi = (n_1 - n) \tan \alpha \cdot dx \quad (8)$$

In other words:

$$\frac{d\Phi}{dx} = (n_1 - n) \tan \alpha \quad (9)$$

On the other hand:

$$\frac{d\Phi}{dx} = \tan \beta \quad (10)$$

where β is an angle formed between tangent versus wave face at point x_1 (after light has passed through object B) and the X-axis (Fig. 8b).

The optical path difference Ψ between the split waves Σ'_0 and Σ'_e at the point under examination (see Fig. 8c)

$$\Psi = r \cdot \tan \beta \quad (11)$$

where r forms transverse displacement of the interfering waves Σ'_0 and Σ'_e (transverse separation).

From the formulae (10) and (11) taken together the following relation can be derived:

$$\frac{d\Phi}{dx} = \frac{\Psi}{r} \quad (12)$$

As to be seen, the optical path difference Ψ in a differential interference image represents a product of both the optical path difference gradient $d\Phi/dx$ and image shearing r . By comparing formulae (9) and (12) a new formula can be deduced to find tangential angle α :

$$\tan \alpha = \frac{\Psi}{r(n_1 - n)} \quad (13)$$

Hence, by measuring optical path difference Ψ at any desired point of the image one can find tangential angle α at relevant point of the object if only difference between refractive indices $n_1 - n$ is known. A few successive measurements of the optical path difference Ψ at some points will provide as a result object profile along any cross-section wanted. If the object profile is known, or if angle α at the given point has been found, it will be possible to determine either the difference between refractive indices $n_1 - n$, or one of the two indices, if only the other one is known. A measurement carried out for two different media of known refractive indices n_1, n_2 will provide in effect angle α and refractive index n . In such a case there are two equations of the formula (13) type from which both the refractive index n and $\tan \alpha$ can be found.

In addition, when one surface of the object under examination remains flat and the other is spherical it will be possible to find curvature R of such a surface after a previous measurement of both angle α and the distance x between apex of the spherical surface and the point at which the optical path difference Ψ has been measured:

$$R = x \frac{\sqrt{1 + \tan^2 \alpha}}{\tan \alpha} \quad (14)$$

Where the object being examined represents a ball having known radius R , the formulae (13) and (14) can be used to find one of the two refractive indices n and n_1 if only the other refractive index remains known.

The optical path difference Ψ within the object under investigation can be found from a change noted in colour, or else may accurately be measured by using the formerly described method of darkening the given point of image and establishing transversal shift of the birefringent prism, performed during this step. For more details of this measuring technique see Chapter 5.

As seen from the foregoing, the differential method offers much more in the sphere of measurement than said method of uniform colour with high image shearing effect. This is, however, not the only advantage to be gained from that method. In addition to numerous applications in the field of quantitative research the differential method offers also some more extremely interesting potentials for the qualitative research. The differential interference image stands out, as a matter of fact, for its high degree of plasticity (in the stereoscopic meaning of the word) and fidelity of representation. Moreover, such an image remains free from the harmful halo effects and other undesirable imperfections typical for the phase-contrast technique. The differential image provides also much more information about the shape, structure and appearance of various objects (both phase and amplitude ones) as compared with the phase contrast microscopy.

2. PRINCIPLE OF OPERATION FOR A POLARIZING INTERFERENCE MICROSCOPE INCLUDING TWO BIREFRINGENT PRISMS

(Application of Shearing Objectives)

The range of applications for a polarizing interference microscope with one birefringent prism in the event of uniform colour method including high image shearing effect (prism No. 3) is confined to the examination of objects having relatively small transverse dimensions, such as biological cells, thin fibres, or such extensile specimens whose edges are steep and which are uniform in their optical path difference.

A far greater image shearing (doubling) in a uniform interference field is possible due to the substitution of ordinary standard objectives, forming part of normal microscope outfit, by the high shearing objectives (or polarizing interference objectives). The introduction of high shearing objectives changes the microscope into a polarizing interference unit whose schematic diagram is presented in Fig. 9.

Prism W_1 (in the interference head) and prism W_2 (in the objective) form, together with the crossed or parallel polaroids P and A and the slit S located in the condenser K focus and disposed so as to be parallel to refracting edge of the prism W_1 , a kind of double polarizing interferometer. Prism W_2 having a relatively large angle of refraction is located right behind the last lens of objective Ob and can be swung about the objective centre line, with plane H_2 in which interference fringes of that prism are being formed coinciding with focus F' of the Ob objective. Another birefringent prism W_1 , having a much smaller angle of refraction φ_1 , is installed in the interference head.

Angular motion of the W_2 prism serves for the adjustment of image shearing values. If this prism remains set so that its angle of refraction φ_2 has the same orientation as angle of refraction φ_1 in prism W_1 ,

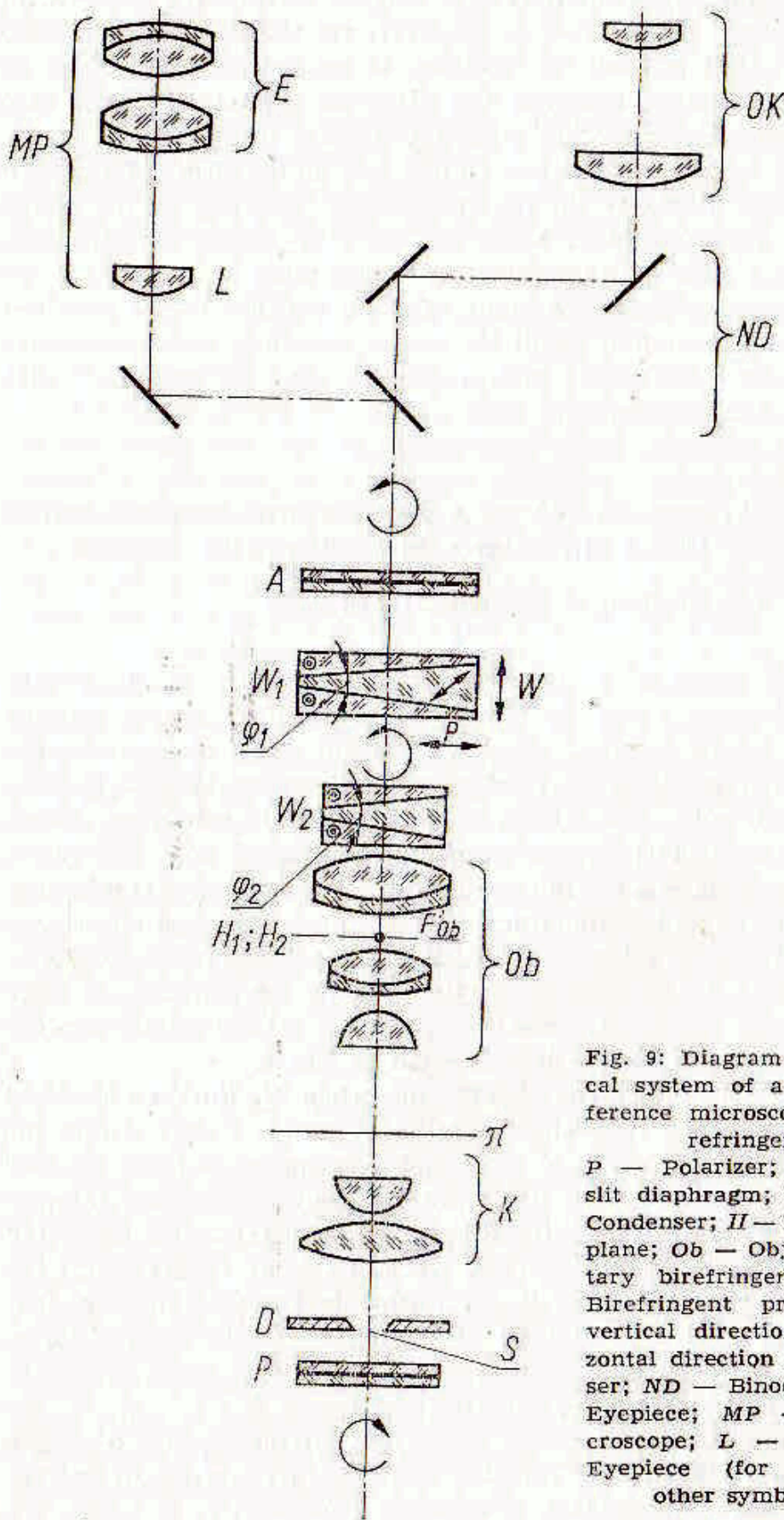

Fig. 9: Diagram illustrating optical system of a polarizing interference microscope with two birefringent prisms

P — Polarizer; D — Condenser slit diaphragm; incl. slit S ; K — Condenser; H — Microscope object plane; Ob — Objective; W_2 — Rotary birefringent prism; W_1 — Birefringent prism slidable in vertical direction „ w ” and horizontal direction „ p ”; A — Analyzer; ND — Binocular body; OK — Eyepiece; MP — Auxiliary microscope; L — Objective; E — Eyepiece (for explanation of other symbols see text)

then a maximum image shearing r — being the sum of shearings r_1 and r_2 produced by each prism separately — will be the final effect. If, on the other hand, prism W_2 has such an orientation that its angle of refraction φ_2 remains reversed versus angle of refraction φ_1 in prism W_1 , then the resultant image shearing r will be equal to the difference existing between shearings r_2 and r_1 . In an intermediate position when refracting edge of prism W_2 forms an angle of 45 degrees versus this of the W_1 prism, the resulting image shearing r will be equal to shearing r_1 to be produced only by prism W_1 . In this case, the system can be referred to this shown in Fig. 1.

It follows then that by rotation of prism W_2 about the Ob objective centre line three different image shearing values, i.e. r_2+r_1 ; r ; and r_2-r_1 , can be found. In these circumstances, it will be possible to select the required image shearing effect quickly and so as to suit actual width of the object under investigation.

Without the need for any objective or birefringent prism replacements as this is usual for the polarizing interference microscopy with only one birefringent prism in operation. The maximum shearing values produced in such a way with objectives of different magnifying powers can be several times greater thus enabling the measurement of optical path difference to be carried out with regard to extensile items, broad biological cells, and even biological sections.

Where use is being made of fringe prism No. 2 (W_1), with prism W_2 having an opposite orientation versus the former (φ_1 reversed versus φ_2), an interference fringed field with a differential image shearing is the outcome of the procedure. Such a possibility does not exist in the optical system employing one birefringent prism only. By shifting fringe prism No. 2 in the vertical direction small differences can be produced in the image shearings, caused by both prisms, and so optimum conditions of observation and measurement can be derived according to the actual width of the item under examination and optical path difference gradients occurring within such an item.

The method of differential interference and fringed field appears to be particularly suitable for the measurement of birefringence in the event of birefringent fibres and films, especially where such fibres and films do exhibit some minor local heterogeneities.

By rotating prism W_2 through 180 deg. so as to make its angle of refraction φ_2 coincide with that of fringe prism No. 2, a high image shearing effect, such as to enable measurement of the optical path difference for both isotropic as well as anisotropic objects along with their thickness, refractive indices and other physical quantities, can be produced.

The availability of a complete set of objectives and birefringent prisms W_2 renders that microscopic examination can be effected using one of the following interference methods:

- uniform colour interference with high (variable) image shearing effect (prisms Nos. 3 and 1);
- uniform interference field differential interference (prism No. 1);
- fringe interference with high (variable) image shearing effect (prism No. 2);
- fringe field differential interference (prism No. 2).

Chapter 2

DESIGN FEATURES OF SPECIAL POLARIZING INTERFERENCE MICROSCOPE COMPONENTS

The BIOLAR PI Microscope incorporates some characteristic components as referred to hereinbelow:

- a) Interference head;
- b) Condenser with slit diaphragm;
- c) Condenser with compensators;
- d) Polarizer complete with its housing;
- e) Auxiliary microscope;
- f) Interference filters: $\lambda=546$ nm; $\lambda=590$ nm;
- g) Polarizing interference objectives;
- h) Measuring eyepiece $\times 12$ including 10/100 microscopic plate.

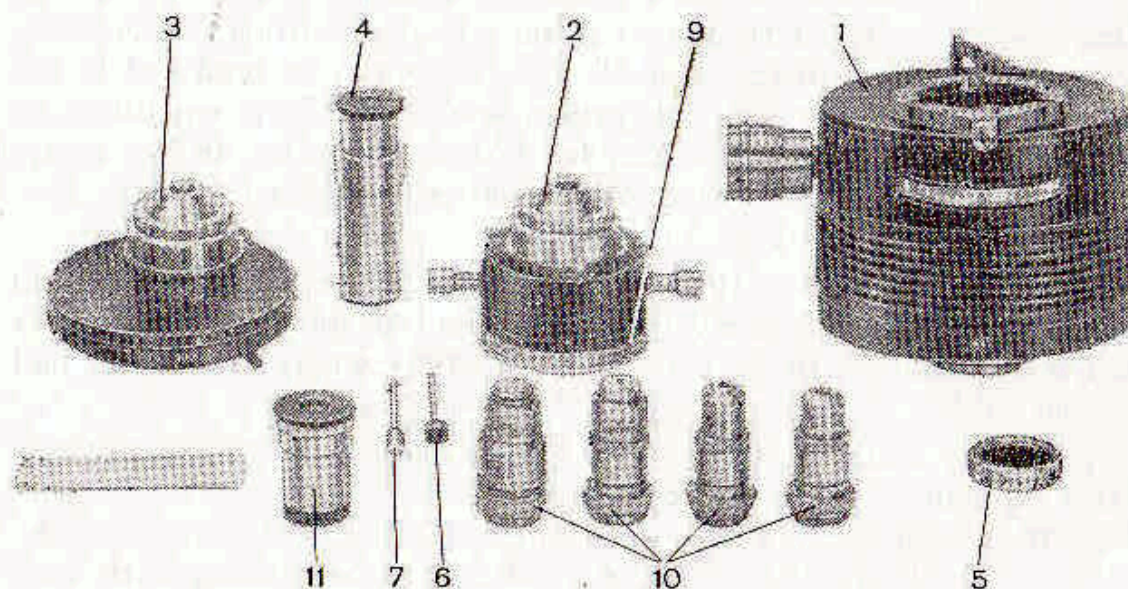

Fig. 10: Basic components of a polarizing interference system

- 1 — Interference head; 2 — Condenser with slit; 3 — Condenser with compensators; 4 — Auxiliary microscope; 5 — Interference filter; 6 — Key for the adjustment of compensators; 7 — Key for tightening condenser in a condenser holder; 8 — Clamping screw; 9 — Polarizer enclosed in a housing; 10 — Polarizing interference objectives; 11 — $\times 12$ measuring eyepiece

Interference Head (Fig. 11) to be installed between the microscope head and binocular or monocular attachment. Inside the lower part of the head a conically shaped element has been introduced to mount the head in a microscope socket. The top part accommodates a seat for the eyepiece attachment and a clamping screw.

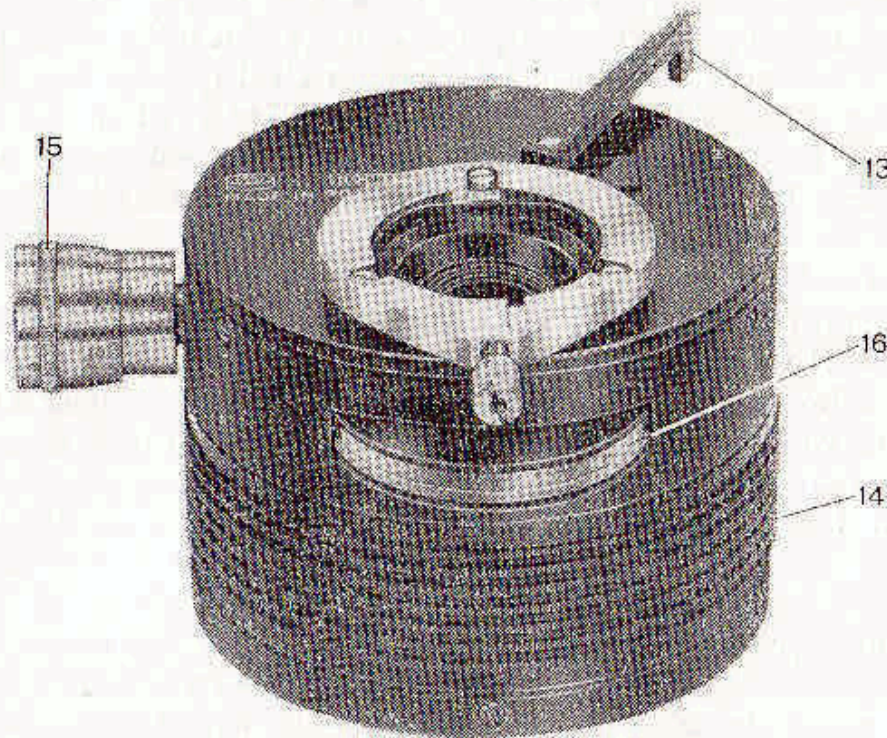

Fig. 11: Interference head

13 — Prism operating lever; 14 — Knurled ring for moving prisms in parallel to the optical axis; 15 — Micrometer screw for perpendicular adjustment of prisms in relation to optical axis; 16 — Analyser in its housing

The interference head houses three birefringent prisms and an analyser.

Birefringent prisms are located in a revolving disk switchable by means of lever 13 of the rotatable type. On top plate figures have been marked to indicate successive positions of the birefringent prisms (1, 2, 3), and an index „0” has been provided corresponding to the free passage of light beam (prism out of operation).

Each of the three interference methods discussed above requires that a separate prism is employed.

Prism No. 1 is being used to carry out uniform colour examination by the differential interference method. Prism No. 2 is reserved for the fringe field interference method, and prism No. 3 for the uniform colour method with a high image shearing effect. In addition to the possibility of a successive engagement (Fig. 11) of prisms in the optical system of the microscope, these prisms can also be moved in two different direc-

tions, viz. in the parallel direction versus microscope centre line and at right angles thereto.

Parallel displacement requires that a knurled ring 14, provided on the head perimeter, is put into action. Vertical movement is achieved through rotation of the micrometer screw head 15 extending to the side. Thimble of the micrometer screw carries a scale with 0,01 mm graduations to enable measurement of the transverse movement of prism.

Parallel adjustment versus optical axis of the microscope (vertical movement) produces a uniform interference field (prisms Nos. 1 and 3) followed by changes in the width of fringes observed in the field of view (prism No. 2) whereas perpendicular adjustment serves for control of phases between the interfering ordinary and extraordinary light waves and for the measurement of optical path difference in the object under observation.

Measuring range for the differential prism (No. 1) is unilateral, being bilateral for the other ones. This means that the differential prism (No. 1) is allowed to move from its zero position (dark background of the field of view) to a greater extent in one direction only whereas the uniform colour prism (No. 3) and the fringe-producing one (No. 2) are movable in both directions (i.e. left and right from zero position).

Analyser enclosed by housing 16 rests in the upper part of the interference head. Housing of the analyser can be rotated through 360 deg. and the analyser itself through 90 deg. On the half of the mount circumference a scale is marked in degrees every 15° from 0 to 90 deg. Opposite this scale a red dot is provided to indicate the out-of-light-beam position of the analyser.

To read the actual position of analyser make use of a notch provided in the upper plate serving as a guard for the analyser.

Condenser with Slit Diaphragm (Fig. 12) represents in fact an Abbe type condenser finding normally use in the microscopy.

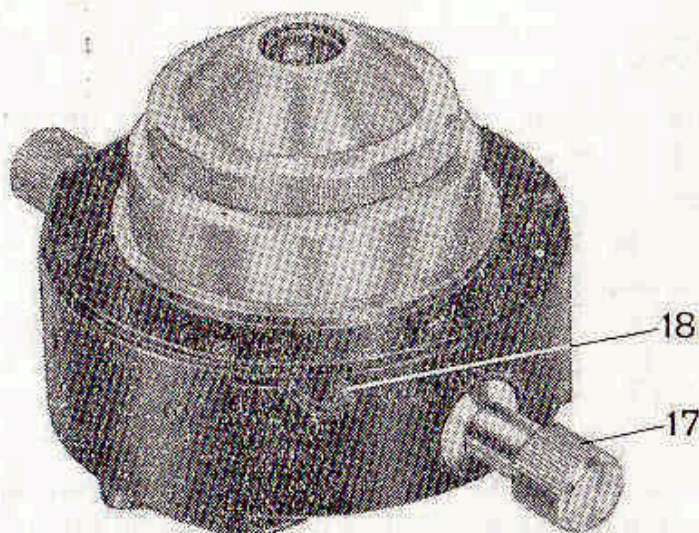

Fig. 12: Condenser with slit
17 — Slit with adjustment; 18 — Slit length limiters

A slit mechanism is permanently connected with the enclosure of the condenser. Slit diaphragm is formed of two jaws mounted in relevant carrying slides. These jaws can be moved independently from each other by means of a pair of controls 17 so as to take any lateral position and to decentre the slit, if required, for getting an oblique beam of light.

The maximum possible separation of jaws is approximately 15 mm. This distance makes it possible to conduct the observation in a normal bright field with condenser aperture increased versus this existing at the slit illumination conditions.

Slit length can be adjusted by means of two symmetrically disposed diaphragms 18. In the bottom part of the jaw assembly provision has been made for guides to mount the polarizer fixed in its position through a ball click.

Polarizer (Fig. 13) represents a kind of polarizing filter cemented into a rotatable ring with the angular scale. This scale has incisions made every 5 degrees in the two opposite directions from 0° to 180° and has a two-sided vernier 20 and 21 to permit angular position of the polarizer for being read with 1° accuracy.

In addition, two symbols „x” and „||” have been marked on the scale between numbers 40—50 and 130—140. These denote crossed „x” or parallel „||” position of the polarizer in relation to analyser set to „45”. The direction of light oscillation coincides with that of the $0-180^\circ$ ring diameter.

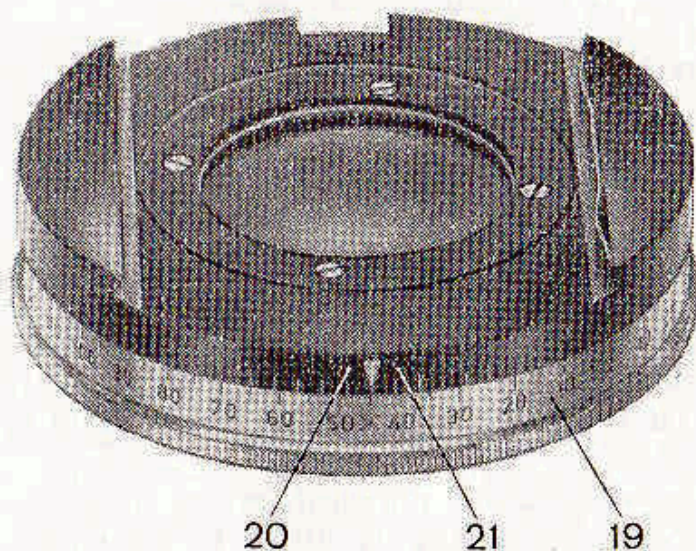

Fig. 13: Polarizer
19 — Angular scale; 20 — Left-hand vernier (nonius); 21 — Right-hand vernier (nonius)

Condenser with compensators (Fig. 14) differs from the former one in that instead of a slit diaphragm it incorporates a system of four quartz compensators suitably disposed in a revolving disk 22. Each compensator has been adapted for use with one of the objectives from the set, i.e. $\times 10$, $\times 20$, $\times 40$, or $\times 100$.

On the revolving disk housing there are marked numerals 10, 20, 40 and 100, with a fixed index being provided on the stationary part of the housing.

A perceptibly locking spring-loaded click is an ease in bringing the required numeral in front of the index. Number 20, when in one line with the index, denotes e.g. that compensator for the $\times 20$ objective has been engaged.

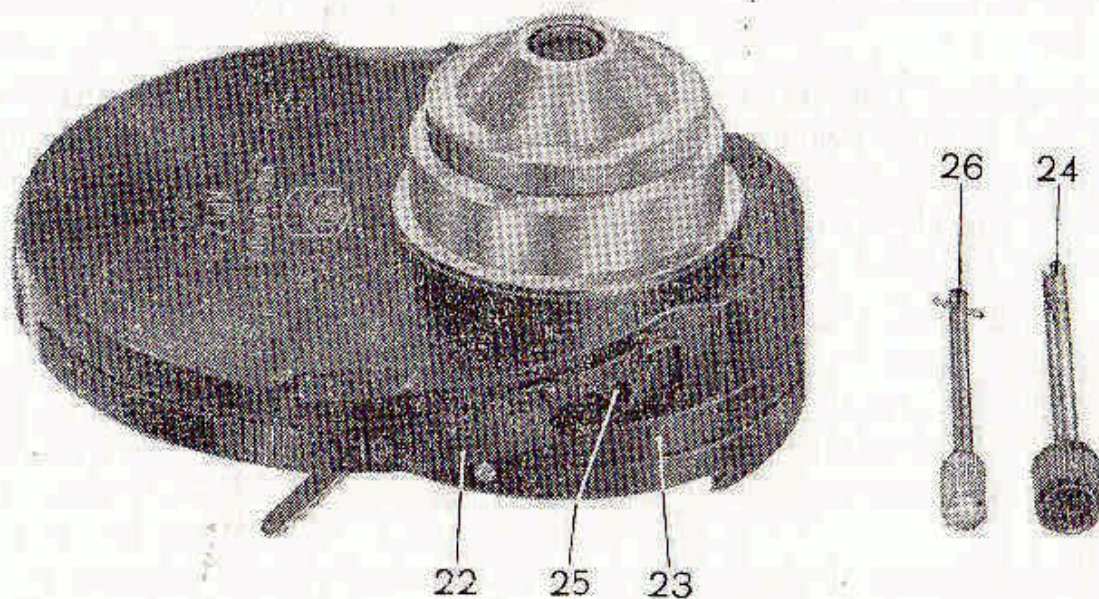

Fig. 14: Condenser with compensators

22 — Revolving disc; 23 — Iris diaphragm; 24 — Key for adjustment of compensators; 25 — Key hole; 26 — Key for tightening condenser with the condenser holder

Each compensator is rotatable within ± 10 degrees which operation can be performed by the aid of relevant adjustment. To achieve the required setting use must be made of key 24 which through opening 25 fits the adjustment screw to positions locked by the click.

In addition to compensators there is still another free opening provided in the revolving disk (marked „0” on the disk circumference) and designed to carry on observations in normal bright field or polarized light.

A small key 26 forming part of the outfit serves for tightening clamping screw of the condenser during its fitting in the microscope substage seat.

The polarizer (Fig. 13) connects with the condenser incorporating compensators in an identical manner as with the slit diaphragm condenser.

Auxiliary Microscope (Fig. 15) has been designed to watch exit lens of the objective and to adjust the microscope with the polarizing interference attachment. It finds use in the generally known phase-contrast microscopy.

Eyepiece 30 is made to move in the objective tube 28. Incisions in the bottom part of eyepiece tube serve the purpose of eliminating clearances between tubes by such a deflection of the tab as to render any fortuitous change in the position of tube impossible.

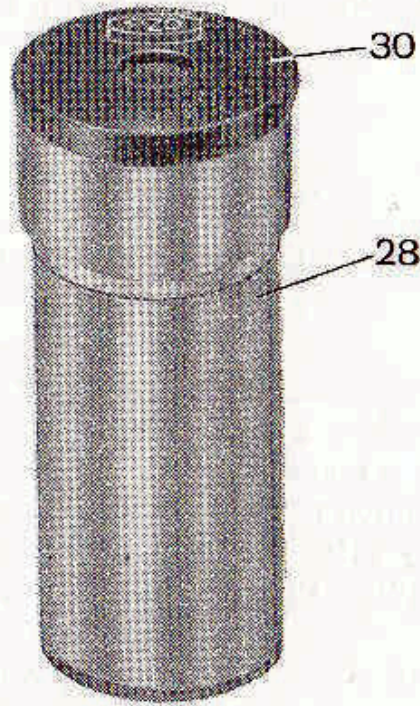

Fig. 15: Auxiliary microscope
28 — Objective; 30 — Eyepiece

Interference Filters 5 (Fig. 10) are intended for the monochromatic light observations. There are two filters which are supplied as standard accessories, a green filter FI 546 and a yellow one FI 590.

Maximum transmittance for the first of them coincides with the mercury green line ($\lambda=546$ nm), and with the sodium yellow line ($\lambda=589$ nm) for the second. The half-wave bandwidth of the transmittance for these filters ranges to about 1 nm, with the transmittance itself exceeding 35%.

Polarizing Interference Objectives — As regards optical system of the polarizing interference objective, referred also to as a high image splitting objective, differs from that of an achromatic one in that it has a birefringent prism installed therein. The prism is rotatable together with the objective optical system through 360° versus a knurled mount which fits objective nose piece being screwed in into it.

A complete set includes objectives of the following magnifying powers: $\times 10$; $\times 20$; $\times 40$; and $\times 100$. These are used exclusively with a slit

diaphragm condenser. Birefringent prisms of said objectives provide the following r_2 values of image splitting (in relation to the object plane):

- 40 μm for $\times 10$ objectives;
- 20 μm for $\times 20$ objectives;
- 12 μm for $\times 40$ objectives;
- 5 μm for $\times 100$ objectives.

The polarizing interference objectives are marked both with a red strip and with letters „PI”.

Measuring $\times 12$ Eyepiece (Fig. 10) is very useful in finding the inter-fringe spacing h for a fringe-producing prism (No. 2).

Chapter 3

PREPARING A MICROSCOPE FOR NORMAL USE

Precision in the adjustment of a polarizing interference microscope is a prerequisite to achieve a good-quality image and to arrive at the best possible results of a measurement.

Accordingly, preparation of a microscope for observations and measurements to be made by different techniques should proceed with a due care and without simplifications in full conformity with directions as detailed below.

The most correct and preferable setting of a microscope is that shown in Fig. 16.

The first step consists in a connection formed between the interference head and microscope limb by means of a clamp 8. Analyser 16 (Fig. 11) should be mounted so as to face the observer. A stud protruding from the lower interference head plate must be aligned so as to engage a groove specially made in the clamp mount to receive it and to prevent thus any inadvertent movement of the interference head.

The next step includes location of the eyepiece 31 in the interference head seat and positioning it with the aid of a clamping screw 32.

The slit diaphragm condenser 2 is to be mounted in the microscope substage condenser 33 (Fig. 17) so as to have the ball click, provided in the lower part of slit mechanism, directed towards the microscope limb. The condenser remains in its mount immobilized by means of a clamping screw 34 (Fig. 17).

The condenser and compensators 3 (Fig. 18) can be installed similarly to that with a slit diaphragm. The only difference consists in using a special small key 7 (Fig. 18) to tighten screw 34 (Fig. 17). A symmetrical positioning of the condenser in relation to substage will be of primary importance.

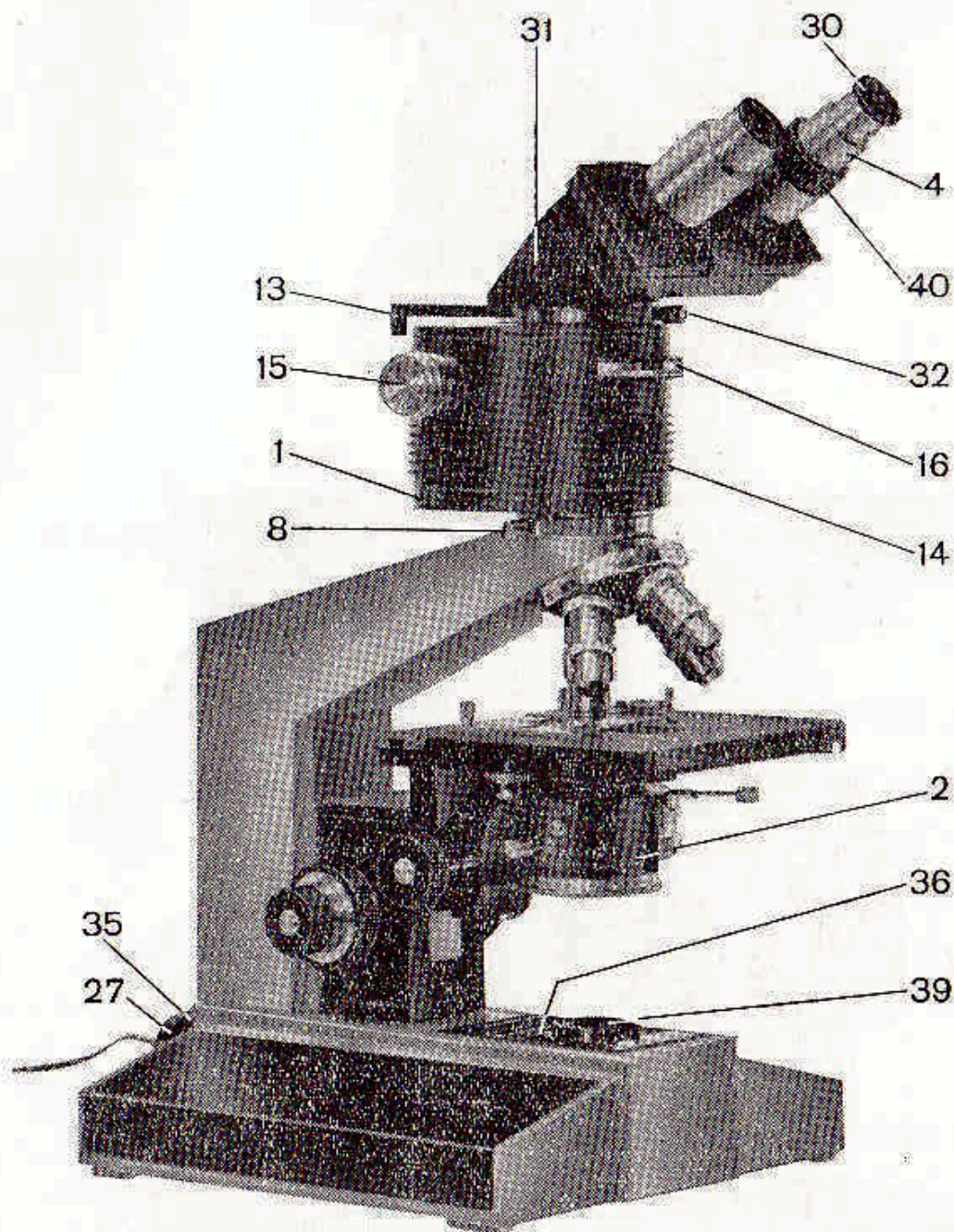

Fig. 16: BIOLAR PI Polarizing Interference Microscope (Condenser with slit)

1 — Interference head; 2 — Condenser with slit; 4 — Auxiliary microscope; 8 — Clamping screw; 13 — Prism operating lever; 14 — Knurled ring for parallel adjustment of prisms in relation to optical axis; 15 — Micro-meter screw for perpendicular adjustment of prisms in relation to optical axis; 16 — Analyser in its housing; 27 — Lamp fitting; 30 — Auxiliary microscope eyepiece; 31 — Binocular body; 32 — Binocular body clamping screw; 35 — Illuminator; 36 — Field diaphragm adjustment; 39 — Filter seat; 40 — Binocular tube dioptic ring

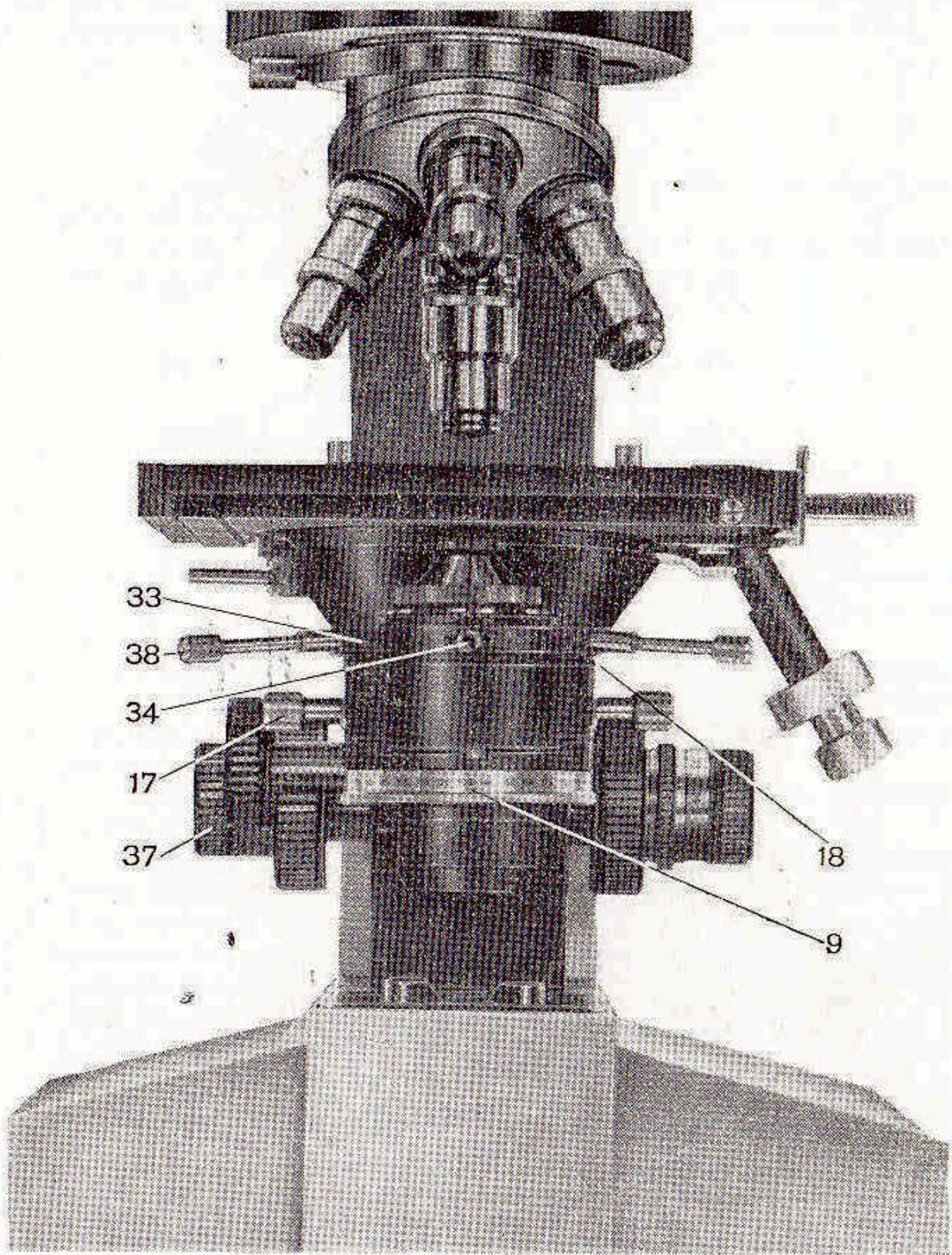

Fig. 17: Lower part of the microscope with slit diaphragm condenser mounted thereon

9 — Polarizer; 17 — Slit with adjustment; 18 — Slit length limiters; 33 — Condenser lift mount; 34 — Condenser clamping screw; 37 — Condenser adjustment; 38 — Condenser control screws

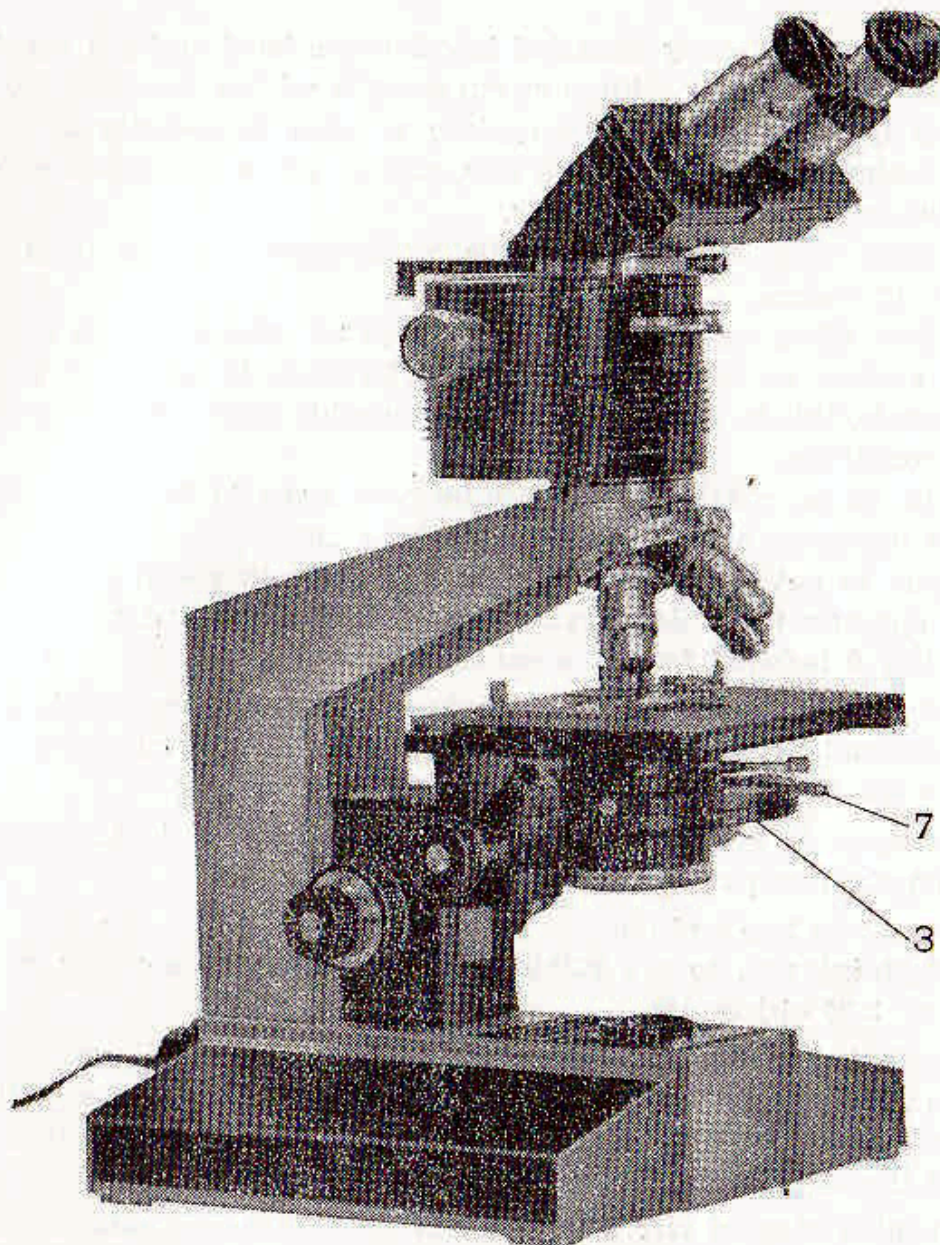

Fig. 18: BIOLAR PI Polarizing Interference Microscope (Condenser with compensators)

3 — Condenser with compensators; 7 — Key for tightening condenser with compensators in its holder

Condenser with the compensators finds use only in conjunction with a differential prism (No. 1) and serves exclusively for the purpose of qualitative investigations where high aperture and much light are required.

For quantitative examinations and measurements only the slit diaphragm condensers are to be used since the so-called „aperture error” may otherwise be the case due to a high aperture characteristic for the condensers with compensators.

1. ILLUMINATION SETTING PROCEDURE

1.1. With the properly installed interference head and slit diaphragm condenser (or condenser with compensators) it will be necessary to screw objectives into the objective nosepiece, to slide illuminator 35 (Fig. 16) into its socket in the microscope foot, and to place respective eyepieces in the binocular attachment tubes.

The lamp is to be connected via a microscope power pack to the 220 V A. C. mains.

The first thing to be done in thus prepared microscope is to set the lighting system in conformity with the Köhler's illumination principle requirements, this to ensure the most favourable observation and measurement conditions.

At this stage, particular accessories will have to be set as follows:

- a) prism changing-over lever 13 in position „0”;
- b) analyser 16 out of operation, i.e. in a position in which a dot is to be seen opposite the index having the form of a sighting notch;
- c) polarizer 9 isolated from the condenser;
- d) slit diaphragm jaws drawn to their extreme positions aside (this to be achieved by operating screws 17 clockwise till resistance) or disc of the condenser with compensators in position „0”;
- e) diaphragms 18 in their extreme OPEN positions, with the front lever moved right and rear one left;
- f) condenser in top position.

1.2. Lighting acc. to the Köhler's principle can be set best by using $\times 10$ or $\times 20$ objectives.

The adopted sequence of steps should then be, as follows;

- a) Place specimen on the object stage; switch on the light and by first operating macro and then also the micro (coarse and fine) adjustment bring the image into focus;
- b) By turning ring 36 left till resistance shut next the field diaphragm, and by manipulating control 37 (Fig. 17) move the condenser so as to focus diaphragm edges in the field-of-view plane; if the image remains out of centre in the observed field of view, its central position will be restored by making use of the adjustment screws 38.
- c) Open field diaphragm so as to completely uncover the field of view; any further continuation of the opening process is not advisable since reflections reducing the image contrast are then likely to be produced.
- d) In place of one of the eyepieces insert the auxiliary microscope (Fig. 16) No. 4.
- e) By using the auxiliary microscope move eyepiece 30 until a sharp image of the objective exit lens is produced (a bright circle of the sharply represented contours to be focused in the field-of-view plane).

- 183
- f) Move illuminator 35 with the lamp in its foot socket to a position in which image of the lamp filament will be in focus when viewing through the auxiliary microscope.
 - g) By applying a swinging motion to the lamp fitting bring the seen filament image into central position of the auxiliary microscope field of view.
 - h) By turning screws 17 of the slit diaphragm condenser there and back (Fig. 17) readjust jaws so as to dispose same symmetrically versus lens centre spaced some 3 to 5 mm far in the apparent field of view.
 - i) Replace polarizer by sliding it onto condenser guides.
 - j) In the event of condenser with compensators omit steps e, f, g, and h, and while observing from underneath the plane of condenser iris diaphragm move lamp in the foot seat so as to obtain a centrally disposed sharp image of the filament seen in the iris diaphragm plane. With the steps as above duly completed proceed with the adjustment proper. This will differ according to the adopted observation and measurement technique.

2. DIFFERENTIAL METHOD — SLIT DIAPHRAGM CONDENSER

2.1. Set lever 13 (Fig. 11) to position "1".

2.2. Shift specimen (by moving the object stage) so as to locate the objective outside the investigated specimen area where no significant optical heterogeneities are encountered.

2.3. Set analyser 16 to scale mark "45" with the polarizer simultaneously moved to "45" or "135" ("x" position).

By viewing through the auxiliary microscope 4 (Fig. 16) and widening the slit a little with the aid of controls 17 (Fig. 17) one can notice in the objective exit lens broad interference fringes together with a dark zero order and coloured fringes of the first, second and further interference orders.

The system of interference fringes and a dark zero fringe comes into existence when the polaroids remain crossed (analyser 16 set to "45" and polarizer 9 to "x"), and this with a bright zero fringe when the polaroids are parallel (analyser set to „45" and polarizer to „11").

Only for these positions of the polarizer 9 maximum intensity of fringes can be had in the objective lens together with a best possible contrast obtained for the image of the object under examination.

The choice of this or another system of interference fringes will depend upon the kind of specimen being observed, and upon the adopted investigation programme. Normally, the system of fringes with the dark zero fringe is to be regarded as preferable.

2.4. By operating controls 17 (Fig. 17) narrow the slit so that its width seen in the field of view be approximately 2 mm, and readjust it so as to produce its image disposed centrally in the objective exit lens (when observed through the auxiliary microscope) and in parallel with the direction of interference fringes.

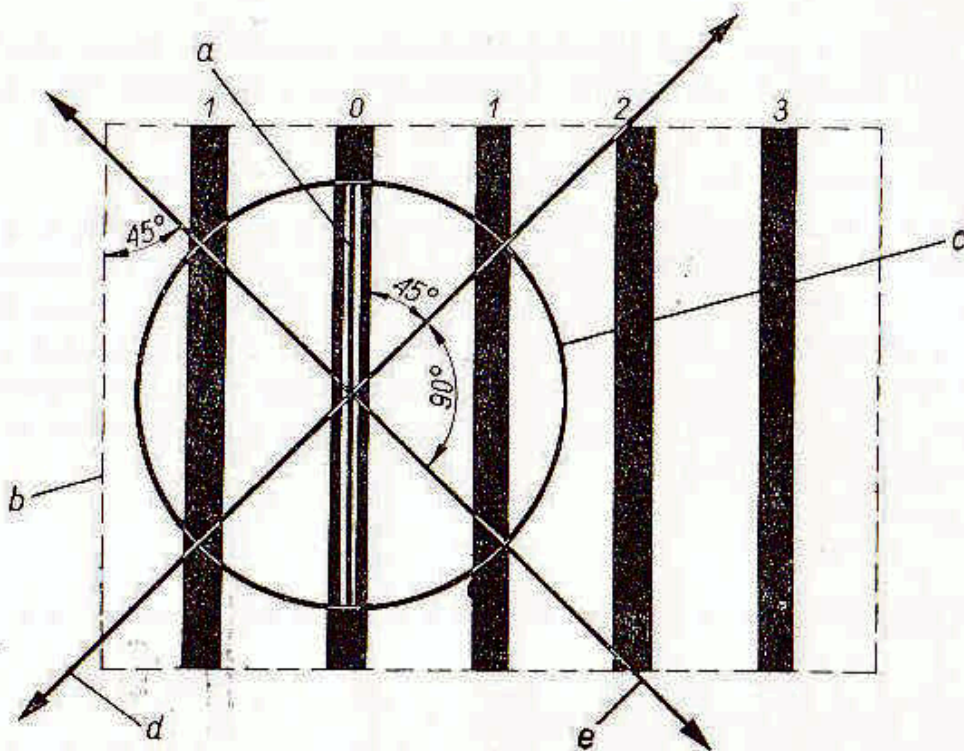

Fig. 19: Objective exit lens
a — Slit image; *b* — Birefringent prism refracting edge; *c* — Objective exit lens; *d* — Direction of light oscillations in analyser; *e* — Direction of light oscillations in polarizer

Should the slit image lack the parallel alignment versus the direction of zero fringe, then the slit diaphragm condenser would have to be a little twisted in the substage condenser mount 33. To do this, slightly loosen condenser clamping screw 34 while holding the very condenser with hand to prevent its fall down. Proceed with tightening it more firmly no sooner than the slit direction has been precisely fixed. Then, establish the required slit width so that only the purple colour be cut out of the first colour fringe (when counting from the dark zero fringe). This fringe is to be brought down to be in one line with the slit image, which operation is to be completed with the birefringent prism shifted by means of control 15 (Fig. 16).

Now, by making use of diaphragms 18 (Fig. 17) reduce the slit in its length to such an extent as to keep the dimension of the fringe being cut out within the confines of that of the objective exit lens diameter.

A mutual orientation of the slit image and interference fringes located in the objective exit lens versus the direction of light oscillations in the polarizer has been shown in Fig. 19.

2.5. If the slit exactly coincides with the purple portion of the interference fringe, the field of view as observed through the eyepiece should remain also completely purple (Fig. 46b) by having the same colour as that "cut out" of the interference fringe by the slit.

Should the field of view lack such a complete purple colouration, with some other adjacent colours (Fig. 46a) being yet present in addition to the purple colour, the conclusion will have to be that the birefringent prism is not at an appropriate distance versus the objective focus. In such a case, the knurled ring 14 (Fig. 16) must be rotated this or another way until a uniformly purple field of view is produced. During the operation of ring 14, the birefringent prism may slightly move aside thus causing fading of the purple colour.

Said colour can be restored by operation of control 15. Special attention must also be given at this stage (particularly when an x10 objective is used) that the image of lamp filament does not coincide with the object plane so as to interfere with the field-of-view uniformity. Should this be the case, the lamp will have to be slightly moved in this or another direction until a possibly uniform field of view is achieved. In some instances, the lack of uniformity caused by the filament can be removed by means of a ground glass to be placed in the microscope foot seat 39 (Fig. 16).

To raise the birefringent prism rotate knurled ring 14 in the clockwise direction, and to lower it a reverse sense of operation is to be applied.

2.6. By controlling substage position bring the specimen in line with the objective field of view, select the required fragment and use fine adjustment to produce a sharp image.

2.7. Remove auxiliary microscope 4 and install in its place a second eyepiece. Readjust eyepiece spacing according to viewer's needs and then rectify sharpness of the image by viewing first with one eye only through the fixed eyepiece and subsequently by operating the diopter correction collar 40 (Fig. 16) of the tube to match movable eyepiece for distinct vision of the second eye. This is a routine usually required when a binocular eyepiece is used.

2.8. With the above steps duly completed, the microscope with a polarizing interference facility can be regarded as ready for use including observations, measurements or microphotography. When changing to an other objective, condenser diaphragms will have to be checked at jaws drawn apart and illumination setting verified with the analyser out of operation by following items 1, 2 (a, b, c) and by completing operations described in Its. 2.4.—2.7.

With so prepared microscope and the uniform field of view coloured purple (first order colour), a similarly uniform field of view will be automatically obtained for any other interference colour.

At one extreme position of the birefringent prism a dark interference field is produced whereas the other extreme position results in an interference contrast of the second and third interference order colours. By setting the birefringent prism to dark field of view, and then by moving it in the opposite direction, an interference contrast in the grey and grey-green field is the outcome (in such a field, the image becomes to some extent similar to a phase-contrast image being, however, much more plastic and without any harmful halo effects characteristic for the phase contrast).

Next, a bright field comes to be seen (the image of phase objects looses on its contrast or becomes hardly visible at all); further on, a yellow colour (providing a rather good contrast) and then orange, purple (sensitive), blue and green appear on the scene.

In between these colours a wide range of transitional colours of various shades is produced. A further shifting of the birefringent prism results in the formation of identical colours of the second and third interference order but with a slightly different hue generally providing a worsened contrast of the microscopic image. Within these colours it is possible to select the best conditions of observation for the specimen to be analysed (good contrast, adequate plasticity and distinct contours of details).

By rotating polarizer 9 (Fig. 17) in either direction through 90° , i. e. so as to bring it into position marked "||", observations can be automatically performed with the polarization planes of the polarizer and analyser 16 (Fig. 16) set in parallel versus each other. A dark field is to be expected in this specific case. Colours within the specific interference orders resemble those characteristic for the crossed polarizer and analyser, but their hue is a little with quite good observation prospects in many an instance.

If one wishes to get quickly a comparison between the nature of image produced by means of a polarizing interference microscope and that by means of an ordinary standard (bright field) microscope, it will be sufficient to disengage the analyser or to twist the polarizer through 45° from its "x" or "||" position.

3. UNIFORM FIELD METHOD INCLUDING HIGH IMAGE SHEARING EFFECT

With the microscope including a slit diaphragm set in conformity with It. 2 shift lever 13 (Fig. 16) to position "3".

Microscope adjustment process proceeds in this case similarly as that in the event of a differential method. With the microscope readjusted to

the uniform field observations, a dark field will be produced (at crossed polarizer and analyser) with the birefringent prism set more or less to its central position. When moving the prism in either direction versus this position, several uniform colours will arise of the first, second, third and subsequent interference orders.

Measurements and observations will have to be carried out as near as possible to the field of view considering the possibility that a certain loss of colour uniformity is likely to occur on field borders.

A microscope with binocular eyepieces is to be employed in such a case.

4. FRINGE METHOD

4.1. Readjust lighting in conformity with the Köhler's illumination principle (It. 1) and then shift lever 13 (Fig. 16) into position "2".

4.2. By adequate movements of the substage position the specimen so as to have the objective outside the limits of the examined specimen area i.e. in the location where no major optical heterogeneities can be experienced on the image.

4.3. Set analyser, as formerly, to "45" and polarizer to "45" or "135" marked by "x".

4.4. Make the slit diaphragm as narrow as possible, with a due attention given at the same time to its central position versus optical axis of the microscope.

A split image of the slit, when viewed through the microscope, ought to be disposed centrally versus the objective exit lens.

4.5 Rectilinear interference colour fringes (Fig. 45), including a dark zero fringe, ought to be seen when looking through the eyepiece. If this is not so, move the birefringent prism in its transverse direction (by making use of control 15) until fringes are to be seen in the microscopic field of view.

Subsequently, with the slightly tightened clamping screw 34 (Fig. 17), rotate condenser in its seat this or other way by operating one of the controls 17 until interference fringes get their maximum clarity and an appropriate brightness, at the same time, in the microscopic field of view is produced.

4.6. With all the above steps brought to an end, the microscope can be regarded as ready for commencing the field fringe observations. When changing from one objective to another it will be only necessary to rectify accordingly width of the slit and opening angle of the field diaphragm and/or central positioning of the condenser. It would be also worth noting that while moving the birefringent prism along microscope axis (ring 14), the interference can be to some extent broadened or narrowed. With the birefringent prism in its upper position the fringes

become narrower, and broader in its lower position. Measurements are, nevertheless, recommended to be taken at the lowest position of the birefringent prism.

Approximate values of the constant p' in Table II exactly apply to this position. Constant p' is to be found each time a higher precision of measurement will be required.

5. DIFFERENTIAL METHOD — CONDENSER WITH COMPENSATORS

5.1. Mount the condenser with compensators in the lifter seat. Slide polarizer (Fig. 13) upon the condenser guides. Condenser itself is to be arranged symmetrically versus adjustment screws 38 (Fig. 17). Clamping screw 34 is to be tightened with a small key 7 (Fig. 18). Analyser 16 (Fig. 16) is to remain as set before, i.e. adjusted to "45", and polarizer 9 (Fig. 17) to „45" or „135", marked „x".

5.2. Produce lighting in accordance with the Köhler's illumination principle (see It. 1) so that the revolving disc is in its "0" position (fully open port).

Observation is to be carried out using a $\times 10$ objective.

5.3. By operating revolving disc 22 (Fig. 14) cause the compensator "10" to enter the beam of rays.

5.4. While observing exit lens of the objective through an auxiliary microscope use control 15 to produce purple (sensitive) colour of the first interference order. Image of the lamp filament in the lens ought to be filled with this colour. Should it happen otherwise so that still some other adjacent colours be visible in the field, condenser in its substage holder 33 (Fig. 17) will have to be rotated this or other way.

Rotation is to be effected no sooner than the clamping screw 34 has been loosened a little with the lower part of the condenser held firmly with the other hand.

Compensators are factory adjusted and therefore no additional adjustment (condenser manipulation) after an objective has been replaced is required, with the condenser brought out of adjustment, i.e. when no such a condition has been satisfied, the position of compensators must be rectified with the use of key 24 (Fig. 14) to be inserted in seat 25.

Once adjusted, the compensators do not call as a rule for a readjustment when reusing the condenser provided the latter has always one and the same position in its holder.

5.5. If the colour of filament image in the lens remains uniform, then the field of view as seen through the microscope eyepiece will be also uniform having the same colouration as the exit lens of objective.

Should it be different, the birefringent prism will have to be brought farther from the objective as prescribed in It. 2.5.

5.6. With all the steps above duly completed, the microscope can be regarded as fit for operation.

Further operations should proceed to Its. 2.6. and 2.7. When changing from one objective to another one, relevant compensator will have to be engaged and steps as referred to in Its. 5.2. and 5.5. repeated. An iris diaphragm 23 (Fig. 14) located under the condenser serves the purpose of narrowing condenser aperture, this applying in particular to the plain „bright field” microscopy with revolving disc 22 set to „0”.

6. APPLICATION OF POLARIZING INTERFERENCE OBJECTIVES

6.1. Differential and Uniform Colour Methods

The microscope is to be now set in accordance with the principles described above and with either No. 1 or No. 3 birefringent prism put into action according to actual needs. Then, a birefringent prism objective is to be provided in place of a standard one and its setting must be such (by operation of its mount) as to see the interference fringes, viewed through an auxiliary microscope, to run parallelly with those of the prism installed in the interference head. In such a case, the two patterns of interference fringes produced by birefringent prisms in action coincide with each other thus producing a new pattern of more dense and narrower fringes.

Subsequently, condenser slit should be narrowed so as to „cut out” of this resultant pattern the first order purple colour. In these circumstances, the field of view should remain uniform in its colour. If this fails to be so, slightly raise or lower the prism in the interference head by operating knurled ring 14 (Fig. 11).

The objective ought to be set so as to have a sharply contoured image of the specimen. With this being so, rotate objective mount with the birefringent prism installed therein through 180° or 45° to obtain other image splitting values.

Should, however, the field of view lack its uniformity after said operation, its initial condition will have to be restored by means of the knurled ring 14 operated in either of the two directions.

6.2. Fringe Method

The microscope is to be set in conformity with the principles specified above and a birefringent prism objective provided in place of a standard one. Now, operate objective mount so as to produce in the field of view the maximum distinction and best contrast interference fringes, and adjust the width of slit accordingly.

CALIBRATION OF BIREFRINGENT PRISMS

1. DETERMINATION OF THE INTER-FRINGE SPACING

The inter-fringe spacing h represents a characteristic quantity of the birefringent prism W_1 provided in the interference head. Prism W_2 in the objective remains without effect on the h value.

1.1. Finding Inter-Fringe Spacing h for Differential Prism (No. 1) and Uniform Field Prism with High Image Splitting Effect (No. 3).

The microscope must be precisely focused and set to a uniform-coloured field of view.

Where monochromatic light with an installed interference filter is employed, the measurement of interfringe spacing h for birefringent prisms providing an uniform field of view will consist in the reading of micrometer screw thimble indications to find a shift in the prism being equivalent with the two successively following maximum darkenings of the field of view.

To achieve a higher degree of accuracy it is recommended to read the difference between the possibly two most extreme positions of the prism where still another dark field of view is produced and to divide the read position difference by the number of successive darkenings of the field of view less one (generally speaking, the difference of prism positions corresponding to the first and n -th darkenings of the field of view is to be divided by the number of darkenings amounting to $n-1$).

Let us assume that e.g. W_1 represents prism position in which the field of view is for the first time completely darkened (maximum darkening), and W_5 another prism position in which the field of view becomes for the fifth time maximally darkened (with the prism travelling all the time in one direction only), then the inter-fringe spacing will be $h = \frac{W_5 - W_1}{4} \mu\text{m}$.

Another procedure includes a method according to which position of the birefringent prism is being read for each maximum darkening of the field of view to find next a mean value of the differences between successive prism positions.

When white light is used, calibration of the uniform field prisms proceeds so that the birefringent prism is set to the dark field of view and then to the first order sensitive colour. The amount of birefringent prism shift occurring during this operation and read from the micrometer screw thimbles is right the inter-fringe spacing h that is looked for. It is also possible to utilize here very sensitive colours of the second and third interference order (on both sides of the dark zero fringe) while finding a mean value from differences between successive prism positions in which a purple field of view is produced.

1.2. Finding Inter-Fringe Spacing h for a Birefringent Prism (No. 2)

Somewhat different is the calibration of a birefringent prism providing the fringed field of view. In such a case, an $\times 12$ measuring eyepiece is inserted in place of a standard eyepiece in the binocular attachment and the prism is lowered into its bottom position, the latter operation is effected with ring 14. Now, by moving the birefringent prism in the transverse direction, centres of interference fringes translocating in the field of view are being set to one of the freely chosen lines of the eyepiece scale with the successive positions of the birefringent prism simultaneously read from the micrometer screw settings. A mean value taken, say, from 10 successive birefringent prism settings gives the interfringe spacing h . Interference fringes remote from the zero fringe should be avoided. It would be preferable to restrict oneself to only five fringes being taken from each side of the zero fringe. Whenever the white light is used, it will be the point where violet changes into blue that should be regarded as a centre of colour fringes.

Table II shows the inter-fringe spacing values h for various positions of the birefringent prisms in the white and monochromatic light observations with wavelengths equal to $\lambda = 590 \text{ nm}$ and $\lambda = 546 \text{ nm}$ respectively. These are theoretical values. For practical reasons, these values are recommended to be determined under the true conditions of investigation.

2. DETERMINATION OF THE CONSTANT p'

Constant p' is to be known if one has to measure the fringed field optical path difference (prism No. 2) by using the method of birefringent prism shift described herein. To find this value it is recommended

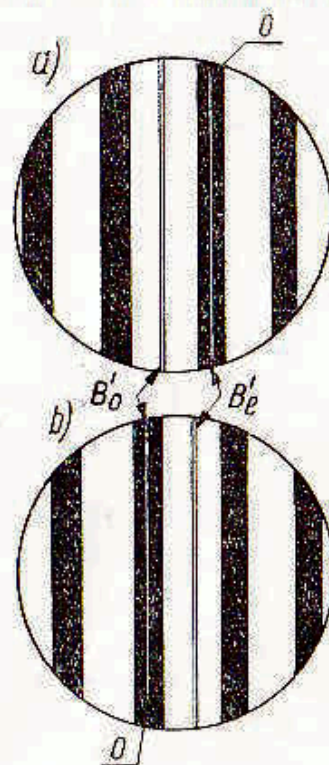

Fig. 20: Method of finding constant p' for a birefringent prism (No. 2) providing fringed interference field effect

a) Centre of dark zero interference fringe (0) when set for an extraordinary image B'_o ; b) Centre of the same zero fringe (0) set for an ordinary image B'_o of a thin fibre or a fine scratch

to use an object slide with a thin scratch or fibre instead of a specimen and to apply an $\times 10$ or $\times 20$ objective. This scratch or fibre must be set parallelly with the interference fringes. After having precisely focused the microscope it will be necessary to shift the birefringent prism transversely and to focus centre of the dark zero fringe (or any other one) first onto one and then onto other scratch image (Fig. 20) while reading from the micrometer screw thimbles amount of the birefringent prism displacement effected during this operation.

For approximate values of the constant p' applying to fringe prism (prism No. 2) refer to Table II.

3. DETERMINATION OF THE IMAGE SHEARING VALUE

The image shearing value r is to be known in relation to the microscope object plane in order to enable measurement of the optical path difference gradient, tangential angle, refractive index and other quantities to be found by the differential interferometric methods (prism No. 1). This image shearing depends on the magnifying power of objective and must be found separately for each objective under the normal operating conditions.

The most simple way of finding this value is to employ a $\times 12$ orthoscopic eyepiece (or micrometer eyepiece) and to measure the distance between images split for a very fine scratch or any other extremely small object which is to be always found on the object glass surface.

The image shearing value read then from an eyepiece scale is to be calculated next so as to get the shearing value related to the microscope object plane. The easiest way for this evaluation are microns. To do this, a micrometric slide — the so-called object micrometer — must be used to determine how many slide graduations fall to one scale interval of the micrometer eyepiece.

One graduation of the micrometric slide supplied with the microscope is $10\ \mu\text{m}$, the entire scale being 1 mm long. For theoretical values of the shearing effect for various objectives refer to Table II.

Chapter 5

MEASUREMENT OF OPTICAL PATH DIFFERENCE

1. FRINGED FIELD MEASUREMENT — BIREFRINGENT PRISM No. 2

This method appears to be especially suitable for examining fine fibres and narrow sections, separated cells and different oval objects not exceeding $32\ \mu\text{m}$ in their diameter, as well as, thin layers and films.

In its most simple form, the measurement of an optical path difference consists in the determination of inter-fringe spacing h' within the microscopic field of view and in finding the amount of deviation d of interference fringes within the image of specimen being examined (Fig. 2).

By knowing these quantities and wavelength λ of the white light having been used one can easily find optical path difference ϕ from the following formula:

$$\phi = \frac{d}{h'} \cdot \lambda \quad (15)$$

The inter-fringe spacing h' and deviation of fringes d can be measured by means of the $\times 12$ measuring eyepiece, or by means of a special micrometer eyepiece available against specific buyer's request. This eyepiece is being used quite in the same manner as other microscope eyepieces. Prior to taking a measurement the eyepiece must be well focused to get a sharply contoured image of the micrometer scale. For this purpose, the focusing lens of said eyepiece has to be operated until a maximum sharpness of the scale image is produced.

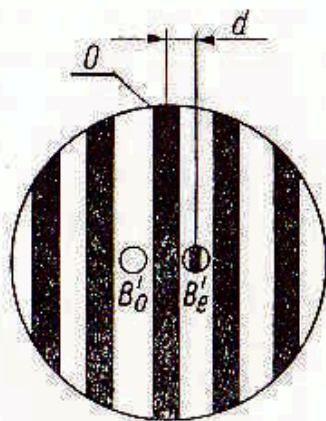

Fig. 21: Optical path difference as measured in the event of small oval objects seen in a fringed interference field

If a fibre, some narrow specimen or any other elongated section is to be examined, it will be preferable to position same by an angular 45° adjustment of the stage in relation to the direction of interference fringes (Fig. 2).

When applying the white light rays it is advisable to perform a measurement by using the dark zero fringe or the first colour fringe as reference. A convenient practice includes in this case reading of a double value d considering, at the same time, the amount of distance between centres of one and the same fringe in both the ordinary and

extraordinary images of the object under examination (Fig. 2). Such a procedure can be, however, adopted only when the object under examination is homogeneous as regards both its thickness and refractive index.

In the event of heterogeneous objects, the measurement of an optical path difference can be referred to a specified point only, and not to the object as a whole. The position of an observed specimen must then be such that the centre of deviated fringe chosen for the measurement could coincide with the required point of one or the other image.

The same effect can be achieved in a much more convenient way by shifting the birefringent prism transversely with the aid of micrometer screw control 15 (Fig. 16) while the specimen remains all the time unmoved. An identical procedure is recommended in the case of oval microobjects (Fig. 21).

Where extensile isotropic objects are involved, whose transverse dimensions do exceed the image shearing value, the measurement of an optical path difference can be carried out no otherwise as only within the split image area limits. By rotating mechanical stage of the microscope one can produce shearing of images for any desirable boundary areas of the object under examination, like e.g. a cell. Since a maximum value of the image shearing for prism No. 2 providing a fringed field is $32\ \mu\text{m}$ ($\times 10$ objective), the diameter of an area in which the optical path difference can be measured by rotation of the specimen will be $64\ \mu\text{m}$. See Fig. 22 for explanations.

In the event of thin layers or films, this method of measurement can be applied to adequately narrow strips, throws or grooves having an angular setting versus the direction of interference fringes (Figs. 23, 24, 25).

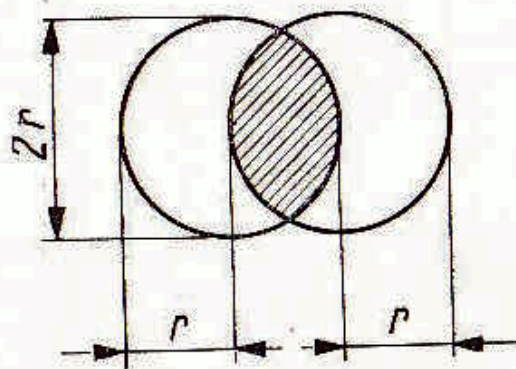

Fig. 22

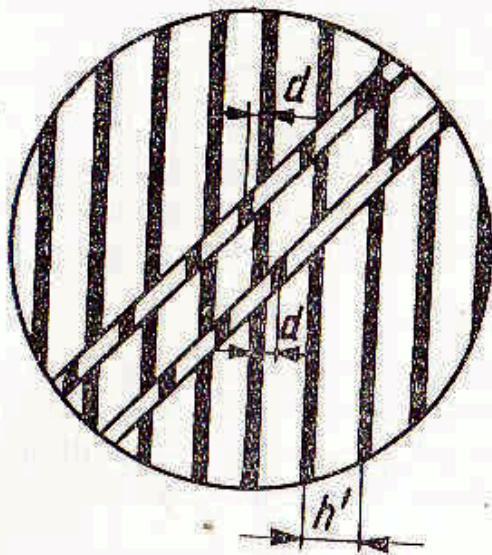

Fig. 23: Image of a sill in the fringed interference field

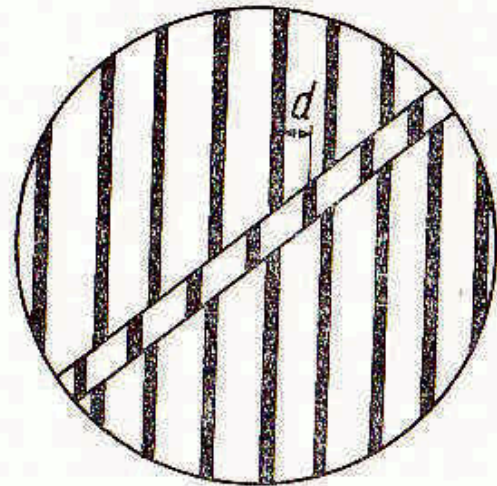
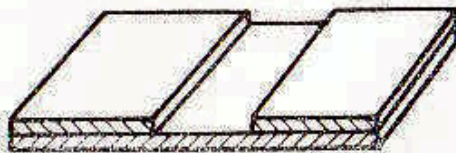

Fig. 24: Image of a step (vertical leap) in the fringed interference field

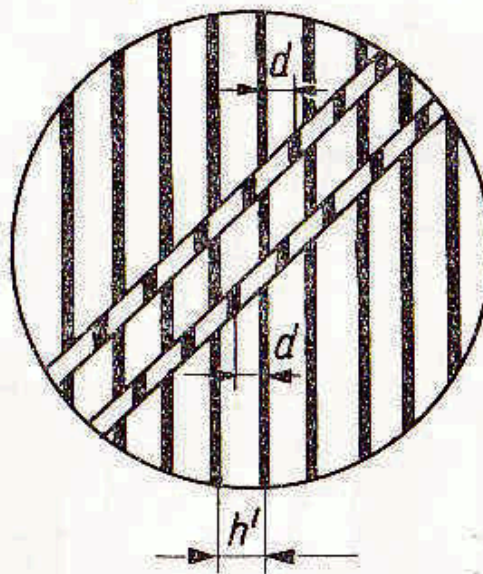
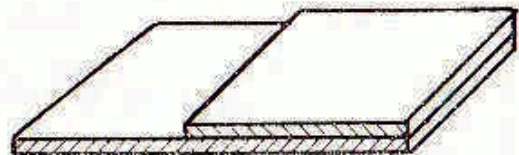
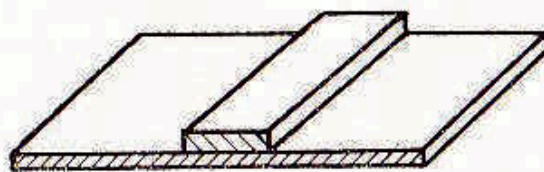

Fig. 25: Image of a groove in the fringed interference field



In the above manner one can measure optical path difference accurately to an order of $\frac{\lambda}{10}$. To achieve a higher degree of accuracy it will be necessary to take photographs of an interference image in order to improve precision with which maximum darkening of the interference fringes will be established by means of a microphotometer or densitometer. In this way, the accuracy in measuring optical path difference will rise to an order of magnitude of $\frac{\lambda}{20}$.

Another method of determining optical path difference in a fringed field includes measurement of the birefringent prism displacement p ($p = p_2 - p_1$) which becomes necessary to produce a maximum darkening of an identical fragment in both images being split with the zero interference fringe (Fig. 26).

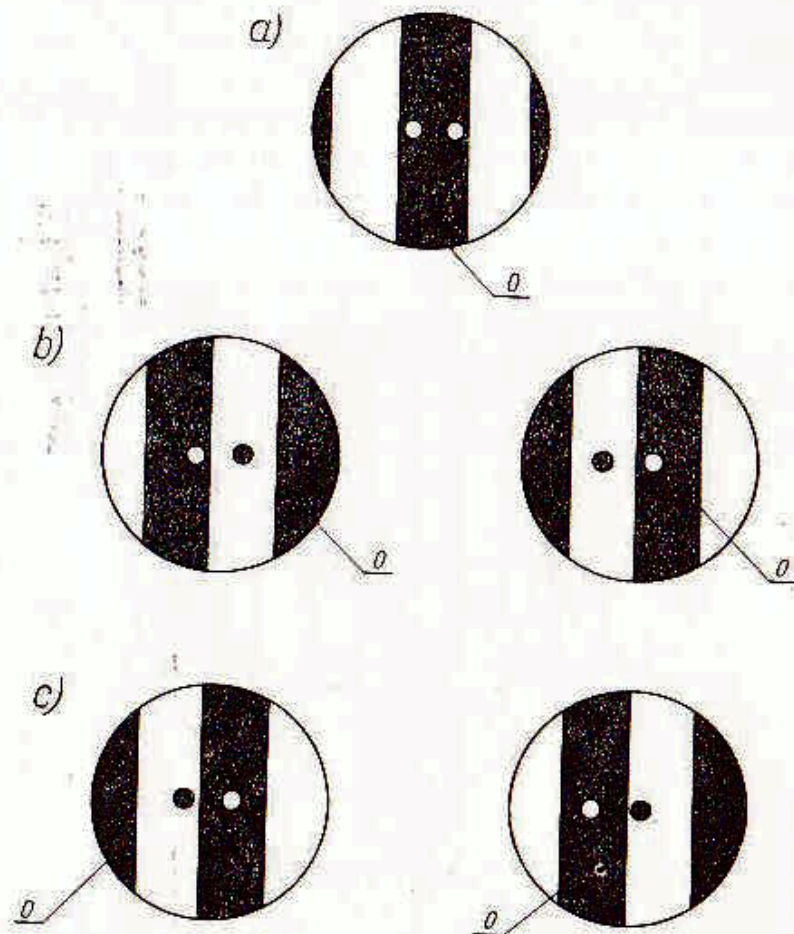

Fig. 26. Optical path difference measured in a fringed interference field with darkening of images and gauging of birefringent prism transversal shift
 a) Dark zero fringe provided to the centre of image of the object under examination; b) Image of the object being investigated, darkened by a zero interference fringe (θ); c) Another image darkened with the same zero interference fringe (θ)

Oblong objects, like fine fibres, narrow strips and grooves, must during this operation remain parallel to the direction of interference fringes.

Optical path difference can be then expressed in the following mathematical way:

$$\Phi = \frac{1}{2} (p - p') \frac{\lambda}{h} \text{ for } n > n_1 \quad (16a)$$

$$\Phi = \frac{1}{2} (p + p') \frac{\lambda}{h} \text{ for } n < n_1 \text{ \& } p > p' \quad (16b)$$

$$\Phi = \frac{1}{2} (p' - p) \frac{\lambda}{h} \text{ for } n < n_1 \text{ \& } p < p' \quad (16c)$$

where:

n — refractive index of the object under examination;

n_1 — refractive index of the immersion medium;

λ — applied light wavelength;

p' — constant for the specified birefringent prism;

h — birefringent prism inter-fringe spacing.

The inter-fringe spacing h must not be confused with the inter-fringe spacing h' referred to above. The value h which may be defined as the actual inter-fringe spacing results from design features of a birefringent prism itself and is expressed by formula (1). For light wavelength being given this will be a constant figure dependent neither on the objective nor on the eyepiece power. The inter-fringe spacing h and constant p' for a white and monochromatic light of a wavelength $\lambda = 590 \text{ nm}$ and $\lambda = 546 \text{ nm}$ respectively can be had from Table II, or be found in a manner as specified above. Since the value of p in Table II has been given in microns, displacement p must be expressed in microns too.

Accuracy for this method is of an order of $\frac{\lambda}{30}$.

This method appears to be particularly suitable for the examination of isolated objects whose images are not entirely separated as yet.

2. UNIFORM COLOUR MEASUREMENTS INCLUDING HIGH IMAGE SHEARING EFFECT — BIREFRINGENT PRISM No. 3

A most universal method of measuring optical path difference with the aid of prisms No. 3, providing an uniform field of view with high image shearing, consists in a transverse displacement of the birefringent prism and in reducing colouration of one of the images having been split to that of the field of view. It is preferable to use for this

purpose a dark colour of the zero interference order. The measurement of optical path difference proceeds by stages so that first a zero position p_0 is found for the birefringent prism to produce maximum darkening of the microscopic field of view (Fig. 27a) and only thereafter the prism can be shifted in an appropriate direction to position p_1 where a maximum darkening of one of the images being split (Figs. 27 b or c) may be achieved. In accordance with the formulae (3) and (4) optical path difference Φ can be written as follows:

$$\Phi = (p_1 - p_0) \frac{\lambda}{h} \quad (17)$$

where:

λ — light wavelength applied;

h — birefringent prism inter-fringe spacing.

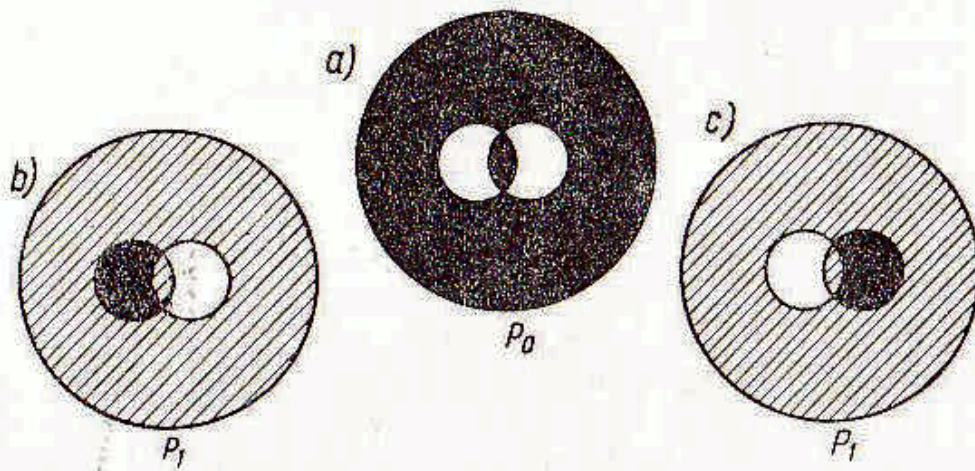

Fig. 27: Optical path difference measured by a method of darkening one of the split images of the object under observation in an uniform interference field

As a consequence, the measurement of Φ can be simply reduced to the micrometer screw thimble readings providing the amount $p_1 - p_0$ by which the birefringent prism has been displaced.

The inter-fringe spacing h is established in the manner as described above, or it can be had from Table II if only measurements have been conducted in the white or monochromatic light with the wavelengths $\lambda = 546 \text{ nm}$ or $\lambda = 590 \text{ nm}$.

Since the values of h in Table II have been presented in microns also displacement $p_1 - p_0$ must be expressed in microns basing on the knowledge that an elementary division on the movable thimble is $10 \mu\text{m}$ and this on the fixed thimble $1000 \mu\text{m}$.

Let us assume, for instance, that the measurement is conducted in a monochromatic light with a wavelength $\lambda = 546 \text{ nm}$. The position p_0 as read from the micrometer screw includes 4 divisions on the fixed thimble and 34 divisions on the movable thimble whereas position p_1

5 divisions on the fixed thimble and 96,5 divisions on movable thimble. By finding displacement of birefringent prism No. 3 in microns the $p_1 - p_0$ difference will be = 5965 — 4340 i.e. 1625. Consequently, the optical path difference

$$\Phi = (p_1 - p_0) \frac{\lambda}{h} = \frac{1625}{830} \lambda$$

If both images of the object under examination remain entirely split, then it will be preferable to adopt a procedure in which the birefringent prism being moved will produce successive maximum darkenings

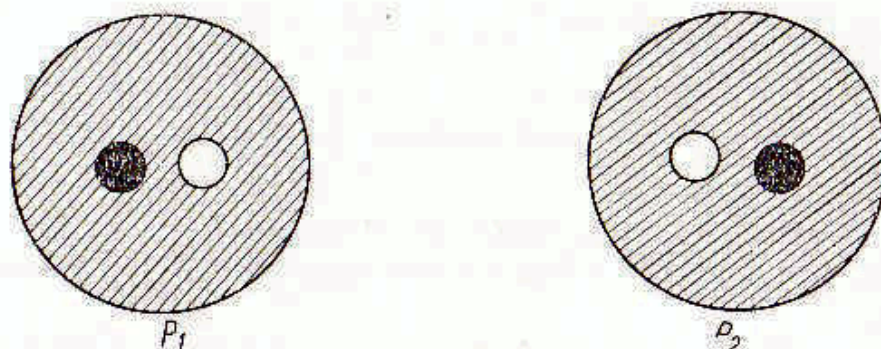

Fig. 28: Optical path difference measured by a method of darkening one and then also the other image of an object under observation in the uniform interference field

of one image and then the second image at one and the same point (Fig. 28). In this case, the optical path difference will read:

$$\Phi = \frac{1}{2} (p_2 - p_1) \frac{\lambda}{h} \quad (18)$$

where: $p_2 - p_1$ is the difference between two positions of the birefringent prism, in which primarily the first and then also the second image become successively extinct to a maximum extent. This practice can also be recommended for the event when both images remain not completely separated (Fig. 27) and the object under examination is, nevertheless, uniform as to its thickness and refractive index and no need arises for the extinction of images at strictly one and the same points.

Should the optical path difference Φ for the object under examination be less than the light wavelength ($\Phi < \lambda$), it will be possible to adopt a procedure by which the birefringent prism can be set in such positions p_1 and p_2 in which the quality of one and then the second image remains the same as the field of view brightness (Fig. 29). In

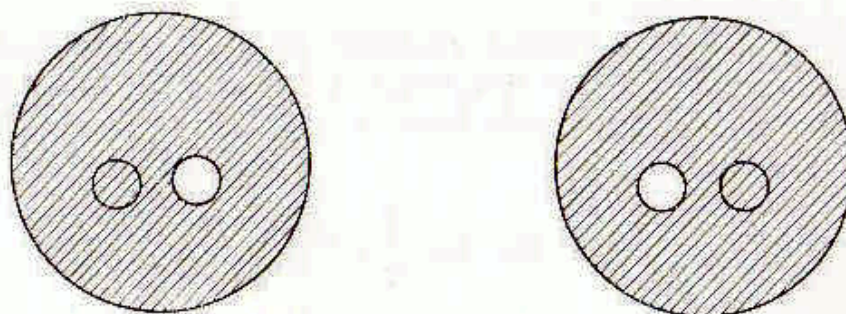

Fig. 29: Optical path difference measured in an uniform interference field by a method of extinction (compensation to suit brightness or colour of the background) applied to one and then also to the other image of the object under observation

these circumstances, the optical path difference Φ can be expressed by the following formula:

$$\Phi = (p_2 - p_1) \frac{\lambda}{h} \quad (19)$$

where: $p_2 - p_1$ represents a difference between birefringent prism positions in which first one and then also the second image become invisible.

If only one image appears in the microscopic field of view (e.g. when measuring throws), then by equalizing brightness of such an image with that of the field of view background a half value of the displacement $p_2 - p_1$ and the optical path difference Φ can be had from the formula:

$$\Phi = 2 (p_1 - p_0) \frac{\lambda}{h} \quad (20)$$

where: p_0 means prism setting for the maximum darkened background and p_1 a setting at which both image and the background remain equally bright. The setting of prism for an equal brightness of the field of view background and image of the object under examination is more sensitive than a setting for maximum darkening, and for this reason the measurement by this method can be more accurate. It is possible, however, only when the object under examination yields an optical path difference not exceeding 1λ .

Since the maximum image shearing value r for prism No. 3 is $6.5 \mu\text{m}$, the diameter of an area within which optical path difference can be measured by the methods referred to above is $13 \mu\text{m}$ (angular movement of the stage) for each point of the object under consideration. Hence, this diameter is smaller than in case of fringed prism No. 2. However, it is the accuracy of measurement which is much better when establishing optical path difference by means of prism No. 3 and this accuracy can in some instances be as high as $\frac{08}{\gamma}$.

When fine lamellae, layers or films are subject to investigation, the optical path difference can be measured by means of prisms No. 3 on adequately narrow strips, throws and grooves with their sharp edges disposed more or less parallelly towards refracting edge of the birefringent prism. Fine fibres and oblong objects must also be set up in a similar manner. Fig. 55 shows an example on how to measure optical path difference for the red blood cells (compare Figs. 27a, b, c).

Methods described in the foregoing exhibit also some disadvantages. In the first method with successive darkening (maximum darkening) of first one and then also the second split image, visual examination and estimation of the maximum darkening effect remains somewhat subjective. The human eye appears namely not sensitive enough to perceive the minimum brightness (i.e. maximum darkening) of the field of view or its fragment. Another method consisting in balancing the brightness of the first and the second image to match it with that of the field of view background can find use only in the event of very fine homogeneous objects.

In biological investigations where heterogeneous specimens undergo the process of investigation only the first method appears to be suitable.

On the other hand, the human eye very well perceives any difference in the brightness of two adjacent fields. This feature has been utilized in a special half-shade eyepiece attachment which provides means for a more accurate measurement of the optical path differences than it would be feasible by the method of a maximum darkening of images split. The main component of this eyepiece includes a half-wave plate located in the eyepiece object plane. By moving the stage, the investigated object can be positioned so that one edge of the half-wave plate strip would form a line of separation for the two parts of images of this object having been split.

The measurement of optical path difference includes transverse shifting of prism W_1 and ensuring to it two such locations at which brightness of the first and then also of the second split image would have been identical within the half-wave space and outside it. Both locations p_1 and p_2 of the prism are read to calculate optical path difference from formula (18). The half-shaded eyepiece attachment has been designed so that both observation of the interference image and objective exit lens have been made possible at the same time. For this purpose a negative engageable lens is used. In the engaged position of this lens, the attachment provides a possibility for interference image observations with simultaneous equalization of the image brightness. The use of microscope attachment with a half-shaded eyepiece renders that optical path difference measurements can be made to an order of accuracy equal to $\lambda/500$.

NOTE: Whenever a half-shaded eyepiece finds use, it will be necessary to disengage analyser A (Fig. 1). The function of this analyser will be performed by another one provided in the half-shaded eyepiece.

3. UNIFORM DIFFERENTIAL FIELD MEASUREMENTS — — BIREFRINGENT PRISM No. 1

As known, the optical path difference Ψ between the ordinary and extraordinary waves in a differential interference image does not expressly reflect optical path difference ϕ within the object under examination but only the gradient of this difference towards the point at which interference waves become split (Fig. 8).

An optical path difference Ψ within the image cannot in such a case be identified with that caused by object under investigation. Optical path difference within a differential image, Ψ , is also easiest to be measured under an uniform dark colour of the zero interference order. With the birefringent prism set to an uniformly dark field of view (p_0 zero position of prism) there will nearly almost appear such a point (or more points) within the investigated object image (of dimensions exceeding the shearing value r) where the observed colour will remain the same as that of the field of view background (see Fig. 47). At these points, fronts of the interference waves adhere each other (are tangent) and the shift reaches a zero value. If Ψ is to be measured at any other point of the object being examined, the birefringent prism will have to be shifted to a position p_1 where a maximum darkening is the outcome.

At this point, optical path difference can be expressed by the following formula:

$$\Psi = (p_1 - p_0) \frac{\lambda}{h} \quad (21)$$

Consequently, the process of Ψ measurement is reduced, as formerly, to the reading of prism shift p_1 minus p_0 from the micrometer screw indications. Interfringe spacing h remains to be determined similarly to the previously described procedure.

Having measured optical path difference within a differential image area one can also find gradient of the differential path difference in an object (formula 12), tangential angle (formula 13), curvature (formula 14), index of light refraction (formula 15) and several other data.

Under favourable conditions of observation, this method ensures an accuracy of measurement for the optical path difference Ψ of an order of $\lambda/250$.

MEASUREMENT OF REFRACTIVE INDEX AND THICKNESS

1. ESTIMATION OF REFRACTIVE INDEX VERSUS THE SURROUNDING MEDIUM

Let us suppose that object B under examination (Fig. 30), having an unknown refractive index n , rests in an immersion medium of a known refractive index n_1 .



Fig. 30

If we now want to find refractive index n it will be necessary to state primarily whether it exceeds or not refractive index n_1 of the immersion medium J . In a phase-contrast microscopy this problem can be solved immediately, but in an interference microscopy the answer is not as easy and requires a certain analysis of the change in interference colours or in the direction of interference fringe deviation. Such an analysis will be easiest to be carried out by the uniformly dark colour or dark zero fringe method.

1.1. Differential Method (Prism No. 1)

As mentioned already before, a specific feature of this method is that within the image of a variable thickness object there will nearly always occur such a point (or more points) where the colour will be identical with that of the background (see e.g. Figs. 47 and 50).

This will be particularly distinct whenever the birefringent prism has been set for the colour of the microscopic field-of-view background. With the birefringent prism being moved in the transverse direction, the dark colour in the observed image will also be subject to a certain amount of displacement. The direction of this displacement will be consistent or not with that of the prism movement, and this will be dependent on whether refractive index n of the object under investigation will be higher or lower than that of the surrounding medium, n_1 .

If the direction of dark colour displacement in the image under observation remains consistent with that of the birefringent prism shift (the prism being initially set for the dark field-of-view background), refractive index n of the object will be higher than that of the sur-

rounding medium, n_1 . Should it be, however, otherwise (direction of dark colour displacement opposite to that of the birefringent prism shift), refractive index of the object under investigation will have to be considered as being lower (n less than n_1).

1.2. Uniform Colour Method with High Image Shearing Effect (Prism No. 3)

In this method, it is recommended to observe the sequence of darkenings for images being split during transversal shift of the birefringent prism in order to estimate the magnitude of refractive index for the object under investigation.

If the sequence of image darkening by a dark colour of the zero interference order is consistent with the direction of shift, refractive index n of the object under observation will be higher than that of the surrounding medium, n_1 , and vice versa, where the sequence of image darkening by such a dark colour remains in opposition to the direction of prism displacement the refractive index n will be lower than n_1 .

1.3. Fringe Method (Prism No. 2)

While shifting the birefringent prism one must notice the side of an interference order zero fringe on which darkening of one or the other image of the object under observation starts to proceed. If the L.H. image darkens on the R.H. side of such a fringe and the R.H. image on L.H. one, refractive index n of the object will remain higher than n_1 of the surrounding medium, and vice versa, if the L.H. image darkens on the L.H. side of the dark zero image and the R.H. image on R.H. side of this fringe the refractive index n will be lower than n_1 .

All the above discussed combinations have been listed in Table III and from its data one can easily find out whether refractive index of the object under observation is higher or lower than that of the surrounding medium.

2. ASSESSMENT OF SURFACE MICRO-IRREGULARITIES

Assume a transparent slide with some microscopic irregularity of the surface. The examination is to find out if we have to do with a concave or convex irregularity.

A qualitative observation of the microscopic image will be not sufficient enough to say something more certain about such an irregularity since one and the same detail often happens to look once as a hill and soon afterwards as a valley. Moreover, in one interference colour it will make an impression of a hill and in an other one of a valley.

However, the interference methods enable the examiner to state beyond any doubt if he has to do with a convey of concave detail of an object. He must only know that refractive index n of the slide under examination is higher or lower than that n_1 of the medium overlying such a slide. Then, by observing the direction of dark colour moving within the image of detail being analysed (differential method), or by noticing succession in which split images (the uniform colour method with a high image shearing effect and the fringe method) will go out it will be possible to check in a similar manner as before in the event of refractive index assessment what the nature of microirregularities observed can be. For various variants of each of the methods refer to Table III.

3. MEASUREMENTS OF THE REFRACTIVE INDEX AND THICKNESS USING INTERFERENCE FRINGE METHOD AND THE METHOD OF UNIFORM FIELD WITH HIGH IMAGE SHEARING EFFECT (i.e. PRISMS NOS. 2 and 3)

Having measured in accordance with the foregoing description optical path difference Φ of an object under investigation in relation to the surrounding medium of a known refractive index n_1 , the operator is in a position to find from the formula:

$$\Phi = (n_1 - n)t \quad (22)$$

what the refractive index n of such an object is provided thickness t of this object is known, and vice versa, he will be able to determine thickness t if he only knows refractive index n (Fig. 30), Φ being positive (+) for $n < n_1$ and negative (—) for $n > n_1$. In order not to commit an error it would be advisable, therefore, to use the previously described procedure for knowing whether the refractive index n of the object under examination remains higher ($n > n_1$) or lower ($n < n_1$) than n_1 of the surrounding medium. Should the measurement of optical path difference be conducted in two immersion media (e.g. in the air and in water, or in the water and some other liquid) of known refractive indices n_1 and n_2 , it would be possible to determine at a time both refractive index n of the object being examined and its thickness t . Two equations would be involved under such circumstances, notably:

$$\Phi_1 = (n_1 - n)t \quad (23)$$

$$\Phi_2 = (n_2 - n)t$$

to find n and t in the following way:

$$n = \frac{\Phi_1 n_2 - \Phi_2 n_1}{\Phi_1 - \Phi_2} \quad (24)$$

$$t = \frac{\Phi_1 - \Phi_2}{n_1 - n_2} \quad (25)$$

whereby optical path differences Φ_1 and Φ_2 have to be considered as positive (+) or negative (—), this in conformity with the aforementioned rule.

The double immersion method can only be used when object under investigation behaves in one and the same manner in both media. Immersion liquids must be chosen, therefore, so that no change takes place in both thickness and refractive index of the object being examined.

Another method for a simultaneous measurement of thickness and refractive index includes optical path difference being measured for two different light wavelengths λ_1 and λ_2 . This method can be, however, utilized only when immersion medium shows high dispersion of the refractive index as compared to that of the investigated object. In such a case, there are two equations analogous with those given in (23) where n_1 and n_2 represent known refractive indices of the surrounding medium, related to wavelengths λ_1 and λ_2 respectively. Cinnamon oil is just the liquid exhibiting such a high dispersion of refractive index.

Yet another method of a simultaneous measurement of the refractive index and thickness consists in the measuring of optical path difference at two different temperatures at which a great change takes place in refractive index of the surrounding medium while refractive index and thickness of the object under investigation remain unchanged or undergo a very small change only.

From Formula (22) it is evident that in order to evaluate refractive index n_1 of an optional immersion medium one must know thickness t and refractive index n of any standard reference object (e.g. thin and narrow glass plate).

4. MEASUREMENT OF REFRACTIVE INDEX BASED ON THE DIFFERENTIAL INTERFERENCE METHOD (PRISM No. 1)

Let us consider any optional object B of a mild optical path difference gradient (Fig. 31). If the tangential angle α at any chosen point H within this object is known, then by measuring in the previously described manner optical path difference Ψ between the interfering wa-

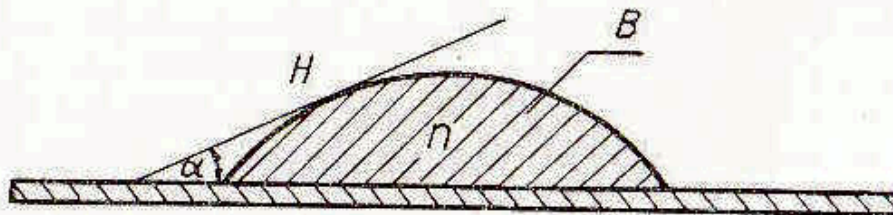

Fig. 31

ves within the interference image of such a point we can arrive at refractive index n of the object B by adopting the following formula (13):

$$\tan \alpha = \frac{\Psi}{r(n_1 - n)}$$

where:

- n_1 — known refractive index of surrounding medium;
- r — image shearing value;

the value of Ψ in said formula is to be considered as being positive (+) if $n_1 > n$, and negative when $n_1 < n$.

If the optical path difference Ψ at any chosen point of the object under observation is measured in two different immersion media having known refractive indices n_1 and n_2 , it will be possible then to determine both tangential angle α and refractive index n .

We have under such circumstances two equations:

$$\tan \alpha = \frac{\Psi_1}{r(n_1 - n)} \quad (26)$$

$$\tan \alpha = \frac{\Psi_2}{r(n_2 - n)}$$

from which n can be derived in the following manner:

$$n = \frac{\Psi_2 n_1 - \Psi_1 n_2}{\Psi_2 - \Psi_1} \quad (27)$$

and so the angle α can be had from one of the equations (26). Optical path differences Ψ_1 and Ψ_2 in equations (26) and (27) are to be regarded as positive (+) or negative (—) according to the rule as given above. To achieve a better accuracy of measurement for the refractive index n , the measurement is advised to be taken at more than only one point with an average value adopted as the final result. Immersion liquids are to be chosen so as to preserve optical and geometrical features of the object completely unchanged.

In addition to the double immersion method also in this case the previously discussed methods of two different light wavelengths and two different temperatures can be employed.

To facilitate the measurement of refractive index in liquids by means of a differential prism (No. 1) special refractometric vessels have been designed, available as optional items. Such a refractometric vessel consists of a basic glass object slide SP (Fig. 32) to which refractometric plate proper, PR , having an oblique step and an auxiliary plate PP are attached. Between these plates a narrow passage is provided to insert a droplet of the liquid C under investigation and to cover it with a microscopic slip SN .

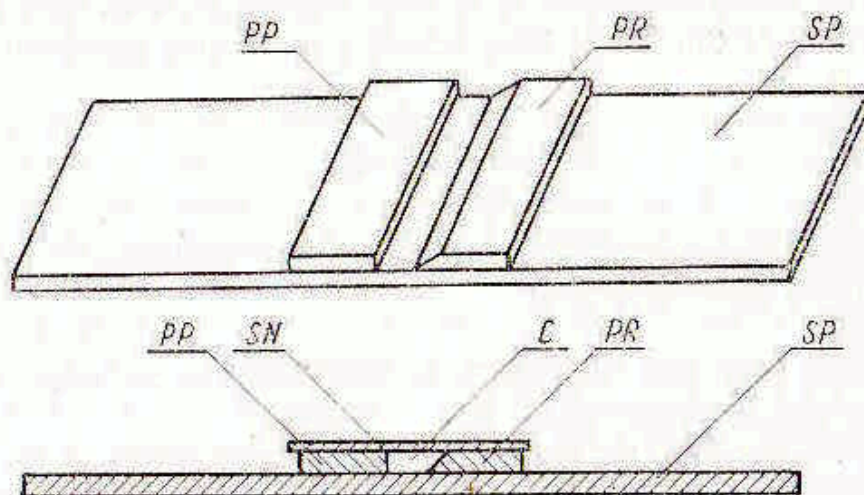

Fig. 32: Cell for measuring refractive index of liquids by a method of differential interference
 PR — Refractometric plate; PP — Auxillary plate; SP — Microscopic slide; SN — Microscopic cover slip; C — Liquid under examination

By measuring optical path difference within the interference image area of the oblique step one can find refractive index n_1 of the liquid C from the following formula:

$$n_1 = n \pm \frac{\psi}{r \cdot \tan \alpha} \quad (28)$$

where:

n — known refractive index of the refractometric plate PR;

α — angle of oblique step in this plate ($\alpha = 45$ deg.)

r — image shearing depending on objective magnifying power (see Table II).

In formula (28) sign „+” applies to n_1 greater than n and „—” to n_1 smaller than n .

The measurement is taken by means of a $\times 10$ objective. Refractometric vessels are located on the microscope stage so that the upper edge of PR plate step be disposed centrally versus the microscopic field of view and parallelly versus refracting edge of the birefringent prism. So, the field of view remains divided into two equal portions, portion I and II (Fig. 33), having different shades if the white light has been employed, or different brightness if monochromatic light has found use.

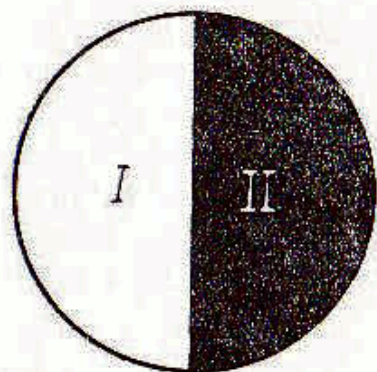

Fig. 33: Field of microscopic view while measuring refractive index by means of a refractometric cell as shown in Fig. 32

Optical path difference Ψ measurement takes place in the uniform dark colour of a zero interference order, with a maximum darkening of the two halves of said field of view done in succession, or by establishing the same level of brightness for both these halves. In the first case, the optical path difference can be had from the formula:

$$\Psi = (p_1 - p_0) \frac{\lambda}{h} \quad (29)$$

and in the other, from the formula:

$$\Psi = 2(p_r - p_0) \frac{\lambda}{h} \quad (30)$$

where:

- p_0 — represents zero position of the birefringent prism, in which maximum darkening of one half field of view providing an image of the refractometric plate behind the step takes place,
- p_1 — represents position of the birefringent prism in which maximum darkening of the second half field of view providing step image takes place,
- p_r — represents position in which both halves of the field of view take on an identical level of brightness.

Both halves can be set for an identical brightness only when the optical path difference Ψ becomes smaller than the applied light wavelength. Setting for a maximum darkening of first one and then also the second half field of view will depend on the visual perception to notice the maximum darkening of the image.

A more reliable setting of the birefringent prism can be had by observing differential image formed in the focal plane of an objective. To this end, an auxiliary microscope must be put in place of one eyepiece of the binocular attachment to be focused in the plane of objective exit lens where two images S_0 and S_1 (Fig. 34) of the slit S

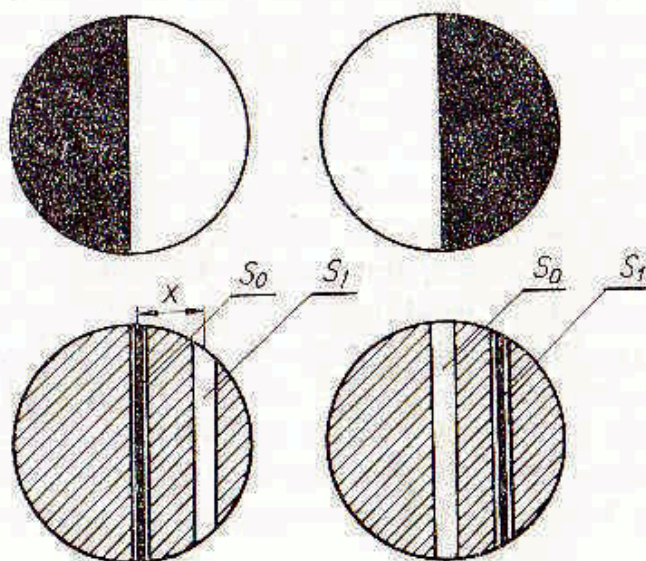

Fig. 34. Refractive index measured in liquids by the differential interference method (using refractometric cell as shown in Fig. 32)

(Fig. 1) can be seen at a time. By shifting birefringent prism in the required direction it must be brought into such a position where a zero interference fringe could pass centrally through one and then also the second image of the slit. Such a position corresponds to the maximum darkening of the first and then also the second half field of view, and is deprived of the uncertainty which assessment of the maximum darkening includes in itself. A precise central positioning of the zero interference fringe just in the middle of images S_0 and S_1 appears to be highly sensitive and guarantees an accuracy of 0.01 mm in the birefringent prism setting, and 0.0001 in the refractive index measurement. Separation x between slit images S_0 and S_1 increases right with the amount of difference between refractive indices of the investigated liquid and refractometric plate. If this difference is small enough, a measurement with the aid of this method becomes impossible since images S_0 and S_1 of the slit coincide with each other.

There are two refractometric vessels in all. They differ in refractive indices n of their refractometric plates PR . The two vessels form a set by means of which one can measure refractive index within the 1.3 to 1.8 interval.

5. MEASUREMENT OF REFRACTIVE INDEX BY THE DIFFERENTIAL INTERFERENCE FRINGED FIELD METHOD (PRISM No. 2)

Refractive index of liquids when measured by the differential interference fringed field method (prism No. 2) requires the use of refractometric vessels as referred to above.

Refractive index for liquids can be had from the formula 28. Optical path difference in formula 28 can be calculated, on the other hand, from formula 15 by measuring an inter-fringe spacing h (as described in Chapter 5) with the aid of an $\times 12$ micrometer eyepiece and by finding interference fringe deviation d (preferably zero fringe) within the skew step area.

An $\times 10$ objective will suit best for that type of measurement. The refractometric vessel must be arranged on the microscope stage in such a way as to have upper edge of the refractometric PR plate step (Fig. 32) in parallel configuration with interference fringes observed in the microscopic field of view.

Then, mechanical stage of the microscope must be adjusted so as to bring refractometric vessel in perpendicular alignment with the interference fringes, but outside the oblique step, and position of the dark zero fringe established by means of micrometric scale eyepiece. After a reading has been taken from the eyepiece scale, oblique step of the refractometric plate PR should be focused in the field of view to read next displacement d of the zero fringe. If the zero fringe displacement occurs towards the liquid under investigation, refractive index n_1 will be less than n and consequently also a negative value of Ψ must be

used in formula 28. If, on the other hand, interference fringes move towards refractometric plate, refractive index n_1 will be greater than n and a positive value of Ψ must be applied to the formula. In this latter case, zero fringe can be observed in the microscopic field of view — within the oblique step area and beyond it, at the same time.

For a definite constant position of prism W_1 under its vertical adjustment, and for a specified refractometric plate, terms $\frac{1}{r \cdot \tan \alpha}$ (in formula 28) and $\frac{\lambda}{h}$ (in formula 15) will remain constant and so the formula 28 can be written, as follows:

$$n_1 = n \pm K \cdot d \quad (28a)$$

where K represents a constant value to be easily determined by measurement of the interference fringe deviation for a kind of liquid of a known refractive index n_1 and for a fixed, preferably the highest and lowest, position of prism W_1 . To improve accuracy, two or three standard liquids can be introduced. Practically, calibration of the microscope (determination of constant K) can be presented in the form of a diagram where refractive indices of the two or three liquids used in the process are plotted under a rectangular coordinate system against the values of zero fringe displacement effected within the refractometric plate oblique step area.

As to be seen from formula 28 relationship thus obtained will represent a straight line intersecting the axis of refractive indices at a point n corresponding to the actual value of refractive index for the refractometric plate in use.

In some cases when dispersion factor of the liquid greatly differs from that of the refractometric plate, the deviated dark zero fringe may have a hue making its identification more difficult.

In such circumstances, to distinguish univocally which deviated fringe corresponds to a non-deviated zero fringe the refractometric vessel must be positioned so as to bring its oblique step edge into perpendicular alignment with the interference fringes, then, it will be necessary to rotate the stage slowly to see which one from the fringes dislocating within the area of said oblique step will join with the dark zero fringe non deviating in the are outside the oblique step.

In such a way, the deviated zero fringe can be easily and accurately identified and this represents an important feature of the method under consideration.

MEASUREMENT OF BIREFRINGENCE

1. FRINGED FIELD MEASUREMENT (PRISM No. 2)

Let us consider any plano-parallel birefringent plate, no matter what its shape, cut out parallelly to the optical axis (Fig. 35).

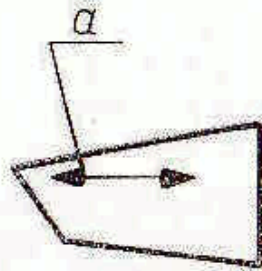

Fig. 35: Birefringent plate
a — direction of optical axis

Such a plate when viewed through a polarizing interference microscope, using the interference fringed field method, will behave differently compared to an isotropic one. Basic difference is that observed in the non-split portion of the image. A plano-parallel isotropic plate would produce no change of the interference field in this portion of the image whereas a birefringent plate could exhibit such a behaviour only if the direction of its optical axis had formed an angle of 45° versus that shown by interference fringes (Fig. 36). There are four such positions available. While rotating microscope stage together with the plate through 360° , the situation will repeat itself at 90° intervals, i.e. every ninety degrees of rotation.

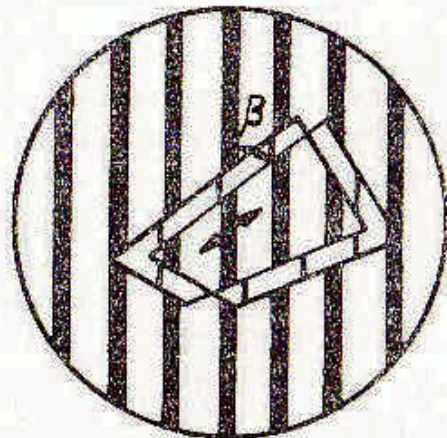

Fig. 36: Birefringent plate in a fringed interference field with its optical axis set an angle of 45° versus the direction of interference fringes

By measuring in one of these positions angle β formed between the direction of interference fringes and any freely chosen edge of the plate one can determine the direction of light oscillation within a birefrin-

gent plate which direction is that of the optical axis and this at right angles thereto. In any other position of the plate, displacement of interference fringes takes place in the non-split portion of the image. If the direction of optical axis in the plate remains parallel or perpendicular versus that of interference fringes (Fig. 37), contrast of the deviated fringes will reach its maximum level. Fringes deviated within a non-split image of the plate do vary in nothing from relevant fringes in the remaining field of view. This creates a situation in which direction of the optical axis can be found with ease also in the birefringent objects. White light is the most convenient source of radiation in this specific case. The recommended procedure consists in such a manipulation of the rotary microscope stage with the object under examination provided thereon that fringes being deviated in a non-split area of the produced image might arrive at the maximum possible contrast and tint identical with that of relevant fringes seen in the field of view.

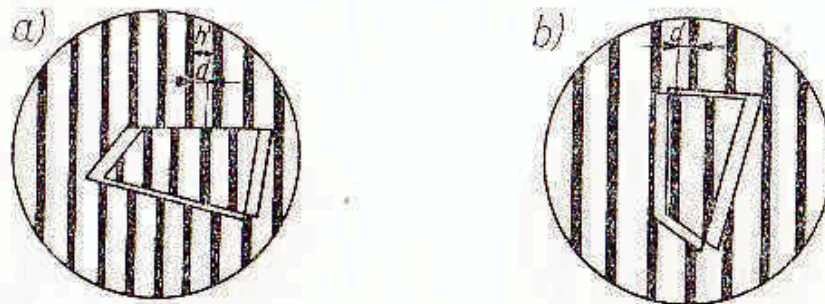

Fig. 37: Birefringent plate in a fringed interference field in perpendicular (a) and parallel (b) alignment versus interference fringes and birefringence measured by establishing deviation d of fringes

Should the investigated object be positive (n_e being larger than n_o) from the birefringent viewpoint, and should fringes deviate in the right-hand direction (Fig. 37a), then the direction of optical axis in such an object will have to be considered as being at right angles to that of the interference fringes. Should, on the other hand, fringes deviate in the left-hand direction, then the direction of optical axis will have to be considered as being parallel towards that of the interference fringes (Fig. 37b). A reverse situation prevails in the event of negatively birefringent objects (n_e smaller than n_o).

By positioning a birefringent plate with its optical axis being perpendicular or parallel towards the direction of interference fringes (Fig. 37), and by measuring in one of these positions the amount of deviation from a dark zero fringe, one can easily find birefringence

$n_e - n_o$ of the examined plate, if he only knows its thickness t , from the formula as follows:

$$\delta = (n_e - n_o) t = \frac{d}{h} \cdot \lambda \quad (31)$$

where:

- n_o — ordinary refractive index;
- n_e — extraordinary refractive index;
- t — plate thickness;
- h' — inter-fringe spacing;
- λ — applied light wavelength.

Optical path difference δ due to birefringence can also be found using the method of a transverse shift of the birefringent prism. For this purpose, the birefringent prism producing a fringed field must be brought to such a position p_0 in which dark zero fringe in the field of view will intersect by a straight line with a specified point B of the image under observation (Fig. 38a). Further on, the same birefringent

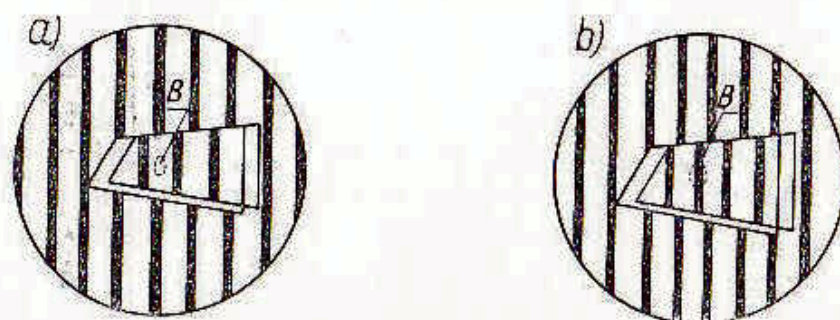

Fig. 38: Birefringence measured in the fringed interference field by displacement of the birefringent prism

prism must be brought to such a position p_1 in which the same zero interference fringe will pass through the chosen point B (Fig. 38b).

Optical path difference δ can be found from the formula:

$$\delta = (p_1 - p_0) \cdot \frac{\lambda}{h} = (n_e - n_o) \cdot t \quad (32)$$

wherein h is the true inter-fringe spacing for a birefringent prism (Table II, Prism No. 2). This method is suitable for measuring very large optical path differences δ (up to 20λ) accurate to an order of $\lambda/20$.

The ordinary refractive index n_o and the extraordinary one n_e can be found by positioning the plate so as to make the direction of its optical axis once parallel and then perpendicular towards that of light oscillations in the polarizer (Fig. 39).

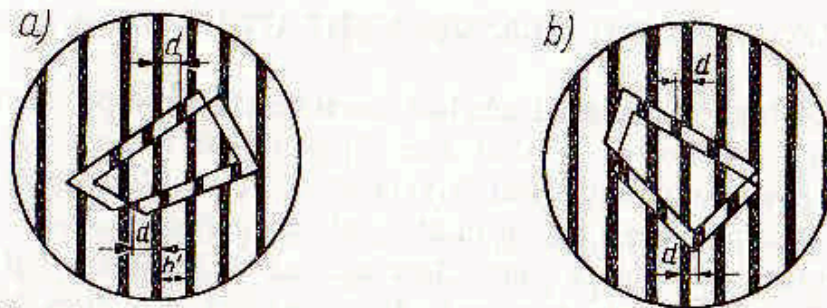

Fig. 39: Ordinary and extraordinary index of refraction for a birefringent plate measured in a fringed interference field by establishing deviation d of fringes

By measuring in both cases deviation d of the zero fringe within the split portion of image one can evaluate optical path difference Φ for the ordinary and extraordinary ray from the formula:

$$\Phi = \frac{d}{h} \lambda \quad (33)$$

If we know thickness t of the plate at the point where optical path difference Φ has been measured, it will be possible to find n_o or n_e from the formula:

$$\frac{d}{h} \cdot \lambda = (n_{oe} - n) \cdot t \quad (34)$$

where:

- n — refractive index of medium surrounding the plate;
- n_{oe} — refractive index of the ordinary or extraordinary ray.

As the optical path difference Φ in two media having known refractive indices n_1 and n_2 has been measured, it will be possible to find at a time also refractive indices n_o and n_e and the thickness t .

If a birefringent prism, which is optically inactive, has been cut out at right angles to the optical axis, then its behaviour will resemble this of an isotropic plate and only the ordinary refractive index n_o will be measured in these circumstances. On the other hand, a thin birefringent plate cut out obliquely to the optical axis will behave like a birefringent plate cut out in parallel to the optical axis, with the only difference that birefringence of such a plate will be smaller since refractive index for an extraordinary ray does not have an extreme value in such a case.

2. UNIFORM FIELD MEASUREMENT (PRISMS Nos. 1 and 3)

If a birefringent plate which has been cut out in parallel with the optical axis is disposed so that the direction of optical axis remains parallel or perpendicular towards this of light oscillations in a polarizer, then no change will occur in the colour of field background to the non-split image of such a plate. During one full rotation of the stage there will be four such positions, therefore, in which a birefringent plate in a not-split area of the image will adopt an identical tinge as the field-of-view background. These positions are being called positions of extinction.

In any other position, which does not coincide with that of extinction, plate image will receive another colour (or brightness if a monochromatic light is applied) whereby the same change in colour will occur four times during a full rotation of the stage. Should, however, the birefringent plate be moved through 45° together with the microscope stage from any freely chosen position of extinction in either direction (depending on whether optical axis of the plate remains perpendicular or parallel towards refracting edge of the birefringent prism), then the colour of image will resolve itself into any initial tinge of the field-of-view background.

An absolute difference in p_o and p_1 positions of a birefringent prism, in which field-of-view background and then also a non-split image of the birefringent prism will adopt the same colouration, is right the measure of birefringence $n_e - n_o$ for the plate under examination:

$$\delta = (p_1 - p_o) \cdot \frac{\lambda}{h} = (n_e - n_o) \cdot t \quad (35)$$

where t represents plate thickness.

With the aid of a differential prism No. 1 one can use this method to measure birefringence only, but when use will be made of prism No. 3 providing a high image shearing effect both birefringence as well as the ordinary and extraordinary refractive indices will be measured.

Said refractive indices are being measured in the split portion of image while the birefringent plate is set in two adjacent position of extinction. Further procedure will be similar to that described above for isotropic objects.

An optically inactive birefringent plate cut out at right angles to the optical axis exhibits in an uniform interference field similar properties as the isotropic plate whereas a thin plate cut out obliquely towards optical axis will behave identically as a plate cut out in parallel to this axis.

MEASUREMENT OF LIGHT TRANSMITTANCE

The polarizing interference microscopy can be used not only for the examination of completely transparent phase objects, but also for the observation of amplitude or — more generally speaking — phase-amplitude objects which absorb to some extent light rays. With regard to such objects, the polarizing interference microscope may perform the function of a microphotometer to measure both the transmittance of light passing through the object and phase displacement, at the same time.

The measurement can be carried out in a uniform interference field as well as in a fringe field with a high image shearing effect where the most convenient practice includes the use of a dark colour or a dark zero fringe (zero interference order).

Assume that the engaged prism No. 3 has been set for a uniformly dark colour of the field-of-view background. The phase-amplitude object absorbing to some extent light rays and having its transverse dimensions smaller than image shearing value r can under these circumstances be seen in the form of two bright separated images (Fig. 40a) similarly to a completely transparent purely phase object.

When shifting birefringent prism in either direction first one and then also the second image (Fig. 40b, c) is darkened. This is, however, not the maximum darkening since amplitudes of the interfering waves, because of light being absorbed by the object under observation, remain not identical within the area of image shearing. To obtain equalization of amplitudes in either of the images, along with their maximum darkening (Fig. 40d, e), the polarizer must be turned in this or another direction (from the position of having been crossed with the analyser) through an angle γ . This angle is used to measure light transmittance P :

$$P = \tan^2(45^\circ - \gamma) \cdot 100\% \quad (36)$$

When darkening one and the same area in the two successively following images of the object under observation, the angle of polarizer rotation should, in principle, remain the same. Considering this fact, it would be advisable so far as possible to measure light transmittance on both images with the mean value of two such measurements taken as the final result. The procedure should be then as follows.

With the crossed polarizer and analyser, birefringent prism must be moved in the transverse direction so as to darken one of the images (Fig. 40b); then, by twisting polarizer in respective direction it must be brought into such a position γ_1 in which the image gets maximum darkening (Fig. 40d). This position can be read from angular scale whe-reafter original position of the polarizer is to be restored (Fig. 40b). By

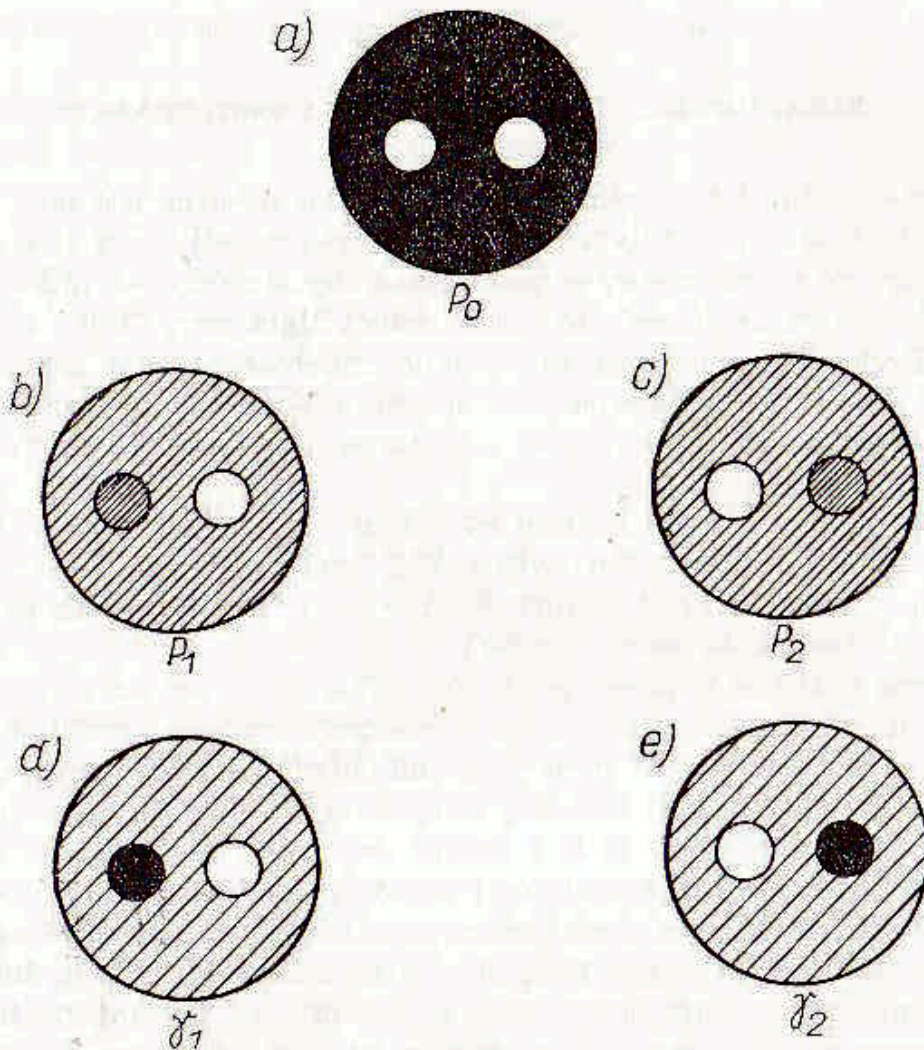

Fig. 40: Simultaneous measurement of optical path difference and light transmittance
 a) Zero position of birefringent prism; b) Compensation of phase shift in L.H. image; c) Compensation of phase shift in R.H. image; d) L.H. image amplitude compensation; e) R.H. image amplitude compensation

shifting birefringent prism in the opposite direction extinction of the second image (Fig. 40c) takes place to yield next to the maximum darkening effect like in the previous step caused by rotation of polarizer in the reverse direction. In this position of the polarizer another reading, referred to as γ_2 (Fig. 40e), is to be taken. The difference of $\gamma_2 - \gamma_1$ when divided by two gives angle γ ; by substituting this in formula (36) transmittance P can be derived.

Suppose, for instance, that $\gamma_1 = 29^\circ$ and $\gamma_2 = 60^\circ$, then....

$$\gamma = \frac{\gamma_2 - \gamma_1}{2} = \frac{31}{2} = 15.5^\circ$$

in other words $P = \tan^2(45 - 15.5)100\% = \tan^2 29.5^\circ \cdot 100\% = 23\%$.

If we take during this operation readings for prism positions p_1 and p_2 , responsible for the maximum darkening of images, it will be then

possible to measure also phase displacements of the light wave passing through the object under observation.

Whenever prism No. 2 is used to produce fringed field, a similar procedure will be adopted to measure transmittance, i.e. with the crossed analyser and polarizer first one and then the second image remains darkened with the zero interference fringe after a previous maximum extinction of the image caused by adequate rotation of the polarizer.

So far, it has been assumed that images of the object remain completely separated. Of course, a complete separation of the images is required only with regard to optically heterogeneous areas lacking uniformity in both phase displacement and amplitude of the incident light wave. On the other hand, in the event of such homogeneous objects like e.g. thin layers, plates or films this requirement must not necessarily be met, and only a partial splitting of the images will suffice. In such circumstances, it is possible to conduct measurements of both transmittance as well as phase displacement on the three fundamental types of samples, i.e. on a sill (Fig. 23), step (Fig. 24) and groove (Fig. 25). The least required among these samples is "step" since measurements can be taken in this case on one image only. In such a situation, highest accuracy must be applied to determine crossed position of the polarizer in which maximum darkening of the field-of-view background is produced. This position may slightly differ from that referred to on the angular polarizer scale as division 45 or 135, marked by a red cross. The instance covering such a type of image can be, however, resolved into this of two images if only mechanical stage of the microscope is moved through 180 deg. together with the specimen.

One of the positions will then yield an ordinary image, and the other an extraordinary one. This procedure is, however, possible only under a uniform colour method technique (prism No. 3); attention must be, however, given during this technique that fragment of the object being viewed has always one and the same position in the field of view.

Angle of Polarizer Rotation

Polarizer (Fig. 13) has an angular scale 19 with incisions made every 5 degrees and marked in both opposite directions from 0° up to 180°. A two sided nonius 20 and 21 ensures an accuracy of 1° for the angular setting readings. Polarizer rotations, accurate to 5°, can be read from the angular scale according to marker ▼ indications whereas those accurate to 1° from nonius 20 or 21 according to whose elementary divisions starting from marker ▼ are on the rising side of angular scale 19.

And so, for instance, polarizer in Fig. 13 has been set to 45° since the angular scale reading is 45° (marker ▼ comes after 45°) and in the left-hand nonius 20 (this is exactly the nonius whose graduations are on the rising side of angular scale 19) it is the fifth mark which coincides with the line of scale 19.

ESTIMATION OF DRY MASS IN LIVING CELLS

Let us assume that a biological cell can be seen as a homogeneous plate of thickness t (Fig. 30) immersed in an aqueous medium. In this cell, optical path difference Φ_w between the incident beam of light that passes through the cell and this passing beyond it will be expressed, as:

$$\Phi_w = (n_w - n)t \quad (37)$$

where:

- n — refractive index of the cytoplasm,
- n_w — refractive index of water.

On the other hand, the following relationship exists between refractive index n_w of the solvent (water in this specific case) and concentration c expressed as m grammes of the cytoplasm dissolved in 100 millilitres of the solution:

$$n - n_w = \delta \cdot c \quad (38)$$

Coefficient δ , referred to as specific increment of the refractive index (or specific refractive increment), remains equal to 0.0018 for most biological substances to be met.

Concentration c , according to the definition given above, can be written as:

$$c = \frac{100 m}{A \cdot t} \quad (39)$$

where A represents the area of cell projection in a plane at right angles to the direction of incident light beam passing through the cell.

From the above three relationships, one can deduce the following expression for the amount of m grammes of the dry mass in a living cell:

$$m = \frac{\Phi_w \cdot A}{100 \cdot \delta} \quad (40)$$

Hence, by measuring optical path difference Φ_w in the manner as described above (uniform interference field with a high image shearing effect, or fringed field method), and by knowing from planimetric measurements area A of the cell, one can use formula (40) to evaluate directly the total amount of dry mass in grammes on a cell submerged in an aqueous medium.

Should the biological specimen under observation have a highly heterogeneous character with different phase shifts occurring at various

points, then the total content of dry mass will have been calculated by summing up particular contents found within different fragments to be considered as being uniform (homogeneous).

In many an instance, and in the comparative research in particular, the knowledge of dry mass m per unit area will be sufficient:

$$m' = \frac{m}{A} = \frac{\Phi_w}{100 \cdot \delta} \quad (41)$$

Whatever is the measurement, it will be solved under such circumstances into a measurement of the optical path difference, Φ_w . By knowing dry mass content per unit area and thickness of the cell, one is in a position to evaluate concentration c of the substance contained therein:

$$c = \frac{m'}{t} = \frac{\Phi_w}{100 \cdot \delta \cdot t} \quad (42)$$

The thickness of a cell, or any other biological object, can also be found in the manner as described in Chapter 6 by using the double immersion or two light wavelength methods.

Formulae (40), (41) and (42) apply merely to biological specimens immersed in an aqueous medium. When a cell is, however, contained in a non-aqueous medium which does not penetrate into the cell, the dry mass content can be calculated from the following formula:

$$m = \frac{\Phi_s \cdot A}{100 \cdot \delta} + (n_s - n_w) \frac{A \cdot t}{100 \cdot \delta} \quad (43)$$

where:

Φ_s — optical path difference of the cell in relation to surrounding medium;

n_s — refractive index of such a medium.

If we want, therefore, to learn dry mass content in a living cell placed under a non-aqueous medium conditions, we must know its thickness t . Should, however, refractive index n_s of the immersion medium only slightly differ from this of water, n_w , then the second term of formula (43) will almost be negligible as compared to the first one. If this is so, cell thickness t can be taken as an estimated quantity found by some approximation methods (like e.g. by measurement of cell diameter if a cell is more or less spherical in its overall shape).

It is not like that if a cell is penetrated by the medium itself. In such a case, the cell can be treated as an agglomeration of cytoplasm particles uniformly distributed within a confined three-dimensional volume penetrated by the medium in question (Fig. 41a). The optical path difference Φ_s caused by the entire cell appears then to be equivalent to that likely to be produced on a layer of densely arranged cytoplasm par-

ticles (Fig. 41b) of an area A identical with this of the entire cell. Let n_c be refractive index of the cytoplasm particles; n_s refractive index of the immersion medium; t geometrical thickness of the cell; and f this portion of the cell which is free from cytoplasm particles.

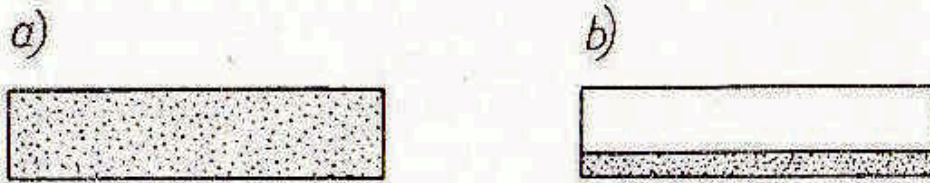

Fig. 41

If only water penetrates into cell from the immersion medium, then optical path difference Φ_s caused by the cell versus the surrounding medium...

$$\Phi_s = (n_c - n_s)t(1-f) - (n_s - n_w)t \cdot f \quad (44)$$

On the other hand, formula (38) under these conditions will have the following form:

$$n_c - n_w = \delta \cdot c = \delta \frac{100m}{A \cdot t(1-f)} \quad (45)$$

By joining equations (44) and (45), the following new expressions can be derived for dry mass content in the cell to be penetrated by water from the surrounding medium:

$$m = \Phi_s \frac{A}{100 \cdot \delta} + (n_s - n_w) \frac{t \cdot A}{100 \cdot \delta} \quad (46)$$

If, on the other hand, immersion medium as a whole penetrates the cell (i.e. both water and substance dissolved therein), then the optical path difference Φ_s will be...

$$\Phi_s = (n_c - n_s) \cdot t \cdot (1-f) \quad (47)$$

and the following expression will be provided for the dry mass content:

$$m = \Phi_s \frac{A}{100 \cdot \delta} + (n_s - n_w) \frac{A}{100 \cdot \delta} (1-f) \cdot t \quad (48)$$

As will be seen, an "effective" knowledge of cell thickness $t = (1-f) \cdot t$ will be required to evaluate dry mass content in the living cell penetrated by the surrounding medium. This dry mass content can also be found by the double immersion method.

To estimate dry mass content in a living cell into which water only penetrates from the immersion medium, geometrical thickness t of the cell will be additionally required.

To find optical path difference in cells and similar biological specimens use can be made of both interference fringe method (Prism No. 2)

and the uniform field method with a high image shearing effect (Prism No. 3). Whichever method is to be adopted will depend to a great extent upon the size of object being examined, the required effect of image splitting and experimental data. Two potentials are then possible:

- either images of the cell (ordinary and extraordinary) will be completely separated (Fig. 42);
- or images of the cell will remain only partially split (Fig. 43).

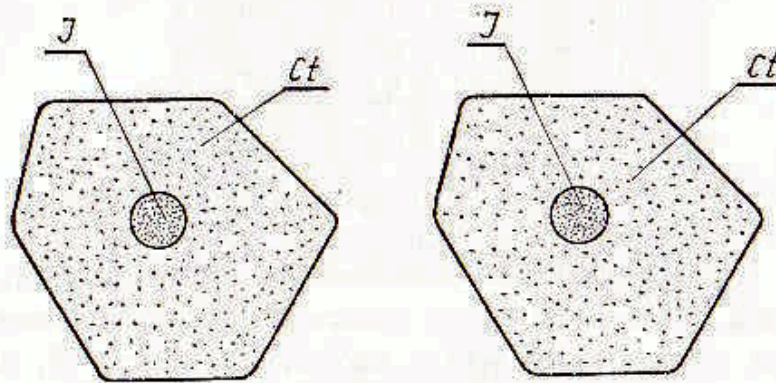

Fig. 42

In case "a" the optical path difference Φ_s versus immersion medium will be measured at any freely chosen point of the cell whereas in case "b" this measurement will only be made within those areas where no overlapping of the images takes place.

Should we, however, have to do with some nucleated cells, then in the event of partial image splitting, it will be possible to measure the optical path difference of the nucleus in relation to cytoplasm. The image splitting value must then be suited so as to produce split images of the nuclei alone, and to keep same within the limits of a joint area of the cell image (Fig. 43). On the other hand, each time a complete separation of the cell images (Fig. 42) takes place, optical path difference will be measured within the limits of nucleus in relation to the cell sur-

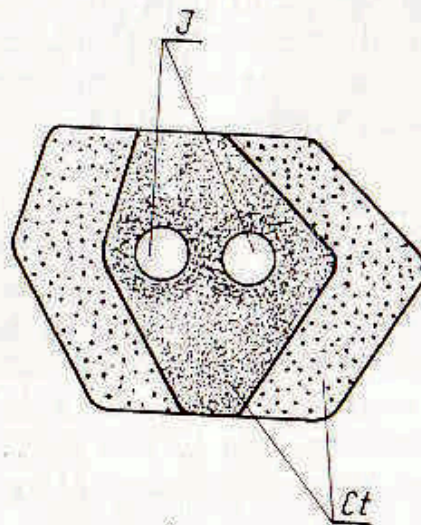

Fig. 43

rounding medium, but including cytoplasm over- and under-lying the nucleus, and this is to be taken into account when proceeding with the analysis of a dry mass content in a nucleus.

Let ϕ_1 represent optical path difference between cytoplasm Ct close to the nucleus and medium surrounding the cell (Fig. 44); ϕ_2 —

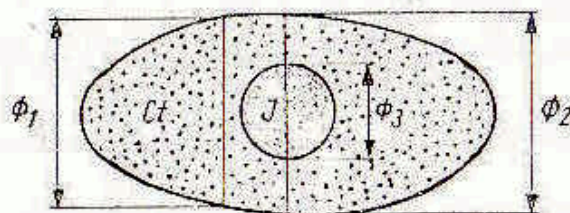

Fig. 44

— optical path difference between nucleus J in its central part, including cytoplasm overlying and underlying it, and the surrounding medium; ϕ_3 — optical path difference between nucleus J and cytoplasm Ct surrounding the nucleus. If we ignore possible difference existing in cell thickness at the point where optical differences ϕ_1 and ϕ_2 have been measured, the following relationship will be true for ϕ_1 , ϕ_2 , ϕ_3 :

$$\phi_2 = \phi_1 + \phi_3 \quad (49)$$

Hence, ϕ_3 can be had by measurement of ϕ_1 and ϕ_2 , or ϕ_2 , can be derived if we measure ϕ_1 and ϕ_3 .

The general principles of dry mass estimation, as well as, those for the determination of refractive index and cell thickness, are intended to orient the reader in existing problems and cannot be treated as completely satisfactory. More details and practical hints about same will be found in publications listed at the end of this booklet.

Naturally, the measurements designed to establish dry mass, refractive index and thickness of a cell do not exhaust by any means all the possible applications of a BIOLAR PI microscope in the biological and medical research. Among the numerous other applications there are e.g. such, as the measurement of light transmittance in absorptive micro-objects, measurement of optical path difference gradient and other quantities, investigation of surface tension effects, diffusion tests, analysis of osmotic reactions, measurement of shape in the event of various objects, etc.

In addition, a BIOLAR PI microscopy offers a great number of new interesting potentialities in the field of qualitative tests and observations due in the first place to high plasticity and fidelity in the representation of interference images (differential images in particular), colour contrast adjustment, possibilities of changing over in a continuous manner from colour contrast to a dark or bright field, high sensitivity of interference methods used in this microscope, as well as, possibilities for observation and examination of both amplitude and phase objects.

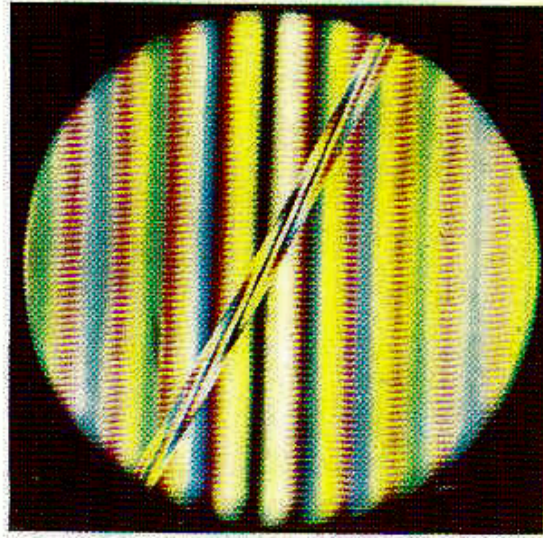
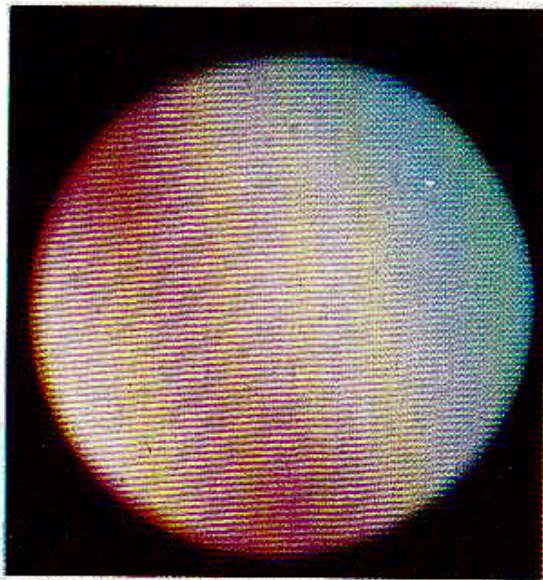
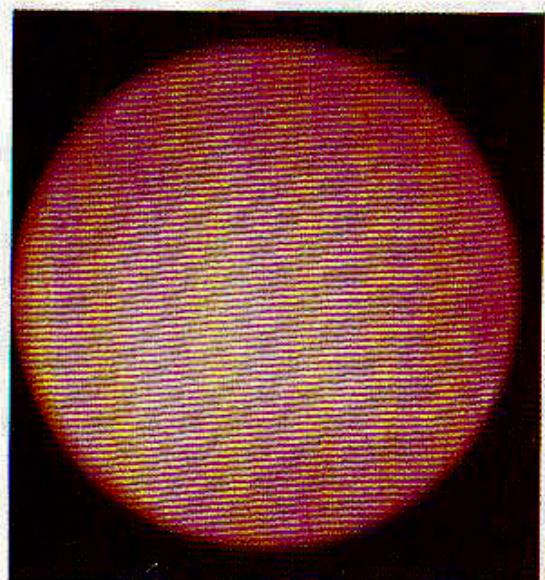

Fig. 45: Fringed interference white light field including a split image of fine Canada balsam fibre immersed in the cedar oil (birefringent prism No. 2; $\times 10$ objective)



a)



b)

Fig. 46: Polarizing interference microscope adjusted for uniform sensitive colour of the first interference order:
a) Wrong setting; b) Correct setting

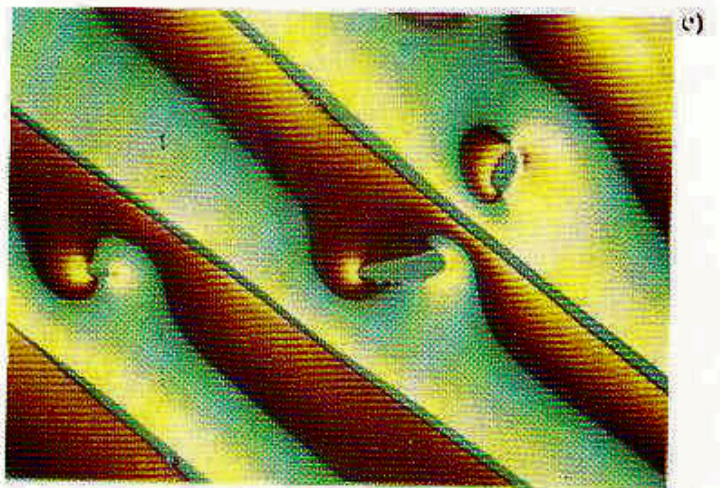
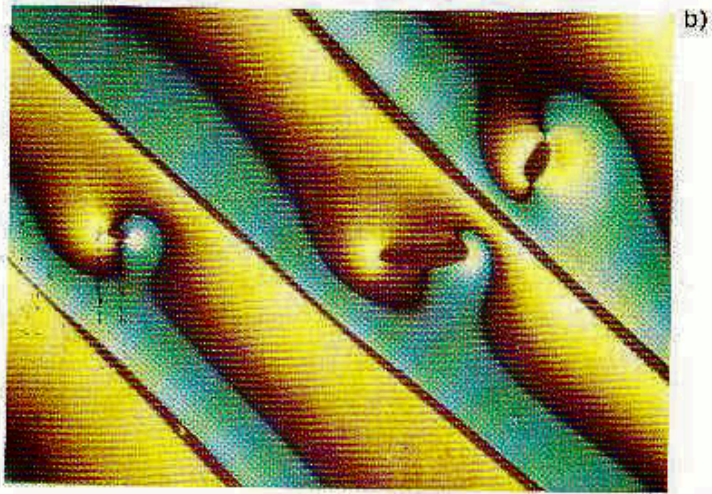
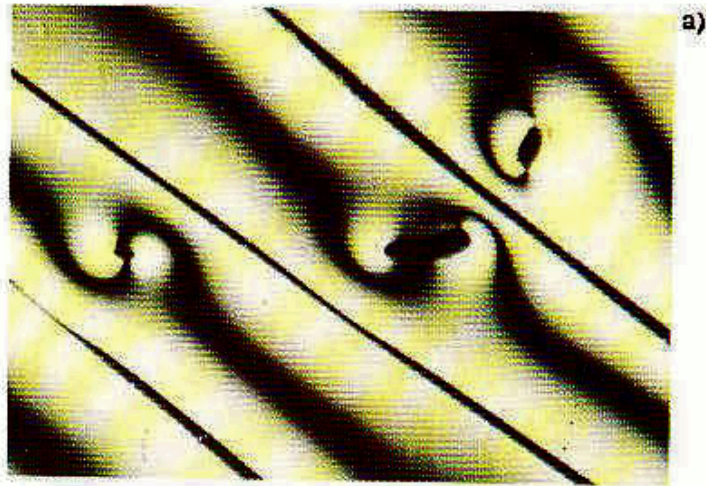
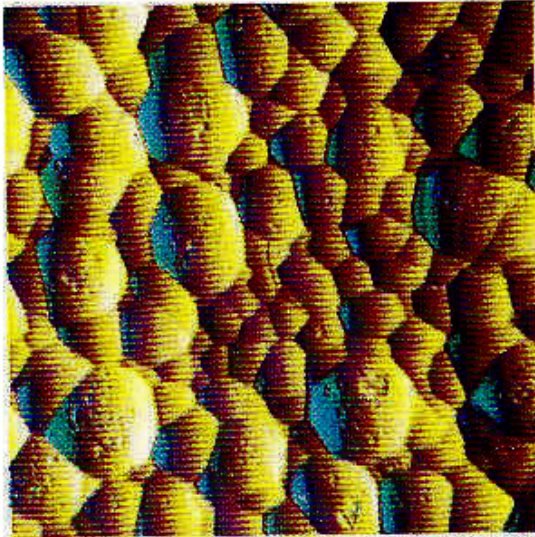
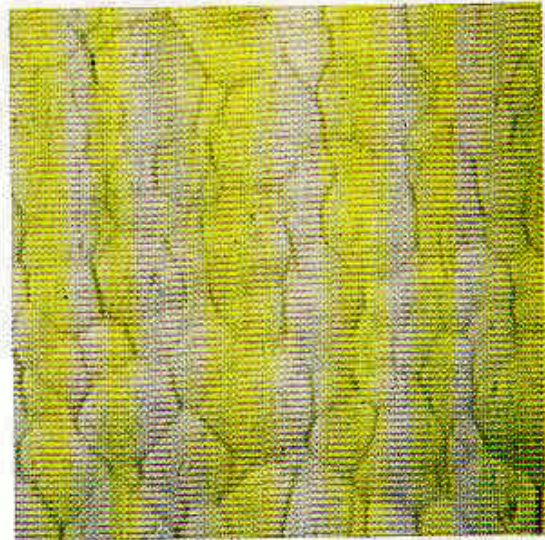

Fig. 47: Image of polyester resin fibre as seen in a uniform interference colour field:
a) Dark colour; b) First order purple; c) First order blue — differential method (prism No. 1; $\times 20$ objective)



a)



b)

Fig. 48: Image of glass plate surface as etched by hydrofluoric acid and flooded with water:

a) As seen in a differential interference field (prism No. 1 set to uniform sensitive colour of the first order); b) As seen in the event of an ordinary bright field microscopy ($\times 20$ objective)

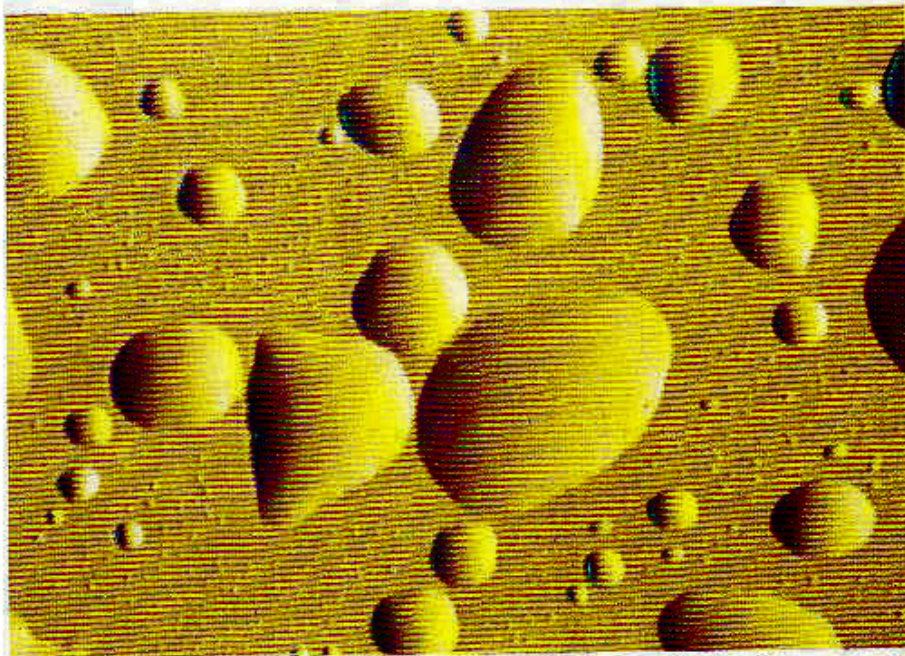
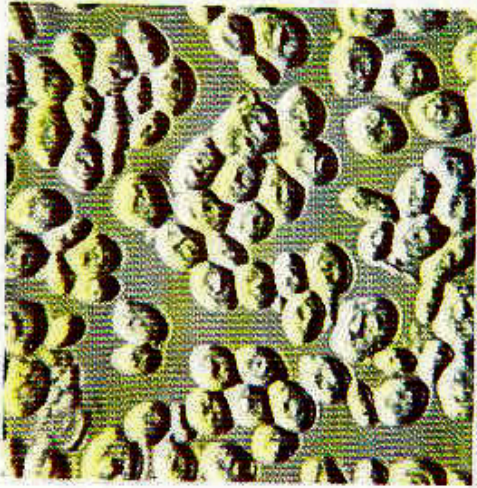
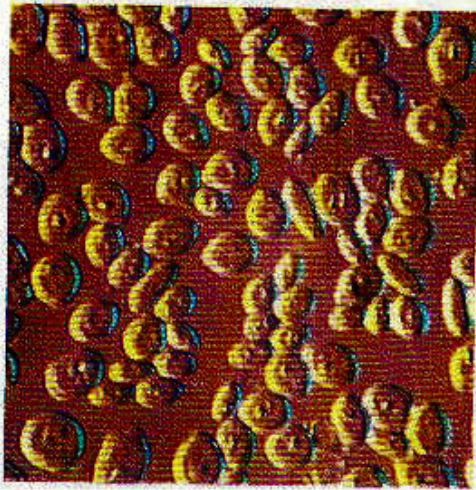

Fig. 49: Cedar oil droplets as seen on a glass slide in uniform yellow-orange colour field of the first interference order — differential method (birefringent prism No. 1; $\times 20$ objective)



a)



b)



c)

Fig. 50: Yeast cells as seen in an aqueous medium

a) Uniform grey-green colour field of view;
b) Uniform sensitive colour of the first interference order (birefringent prism No. 1; X100 immersion objective); c) Ordinary bright field microscopy

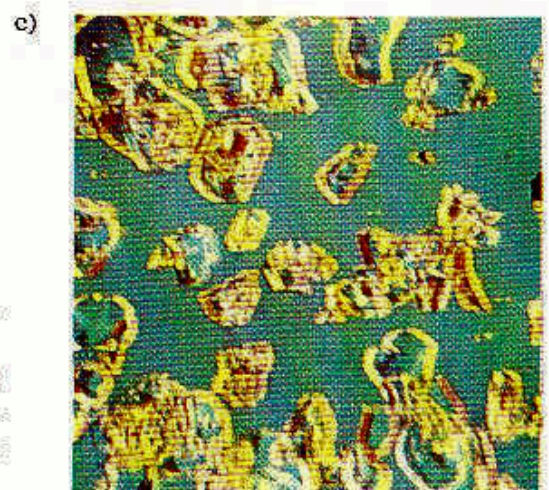
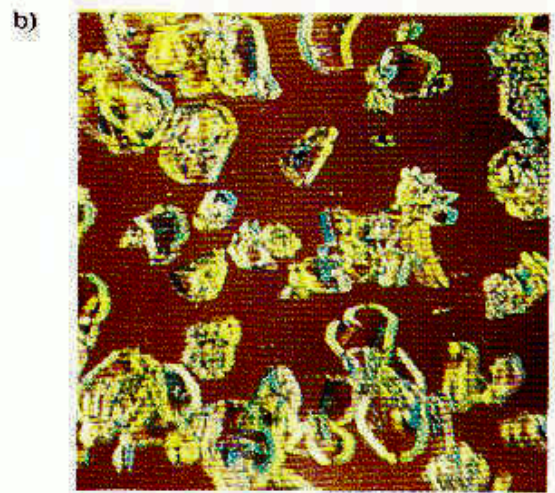
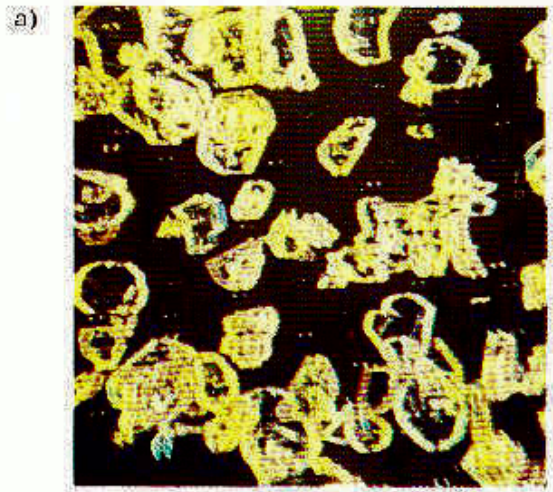

Fig. 51: Corundum crystals as seen in a uniform colour field:

a) Dark colour; b) First order purple; c) First order blue — the method of uniform field with a high image splitting effect (prism No. 3; $\times 100$ objective)

1870
1871
1872
1873
1874
1875
1876
1877
1878
1879
1880
1881
1882
1883
1884
1885
1886
1887
1888
1889
1890
1891
1892
1893
1894
1895
1896
1897
1898
1899
1900

1901
1902
1903
1904
1905
1906
1907
1908
1909
1910
1911
1912
1913
1914
1915
1916
1917
1918
1919
1920
1921
1922
1923
1924
1925
1926
1927
1928
1929
1930
1931
1932
1933
1934
1935
1936
1937
1938
1939
1940
1941
1942
1943
1944
1945
1946
1947
1948
1949
1950

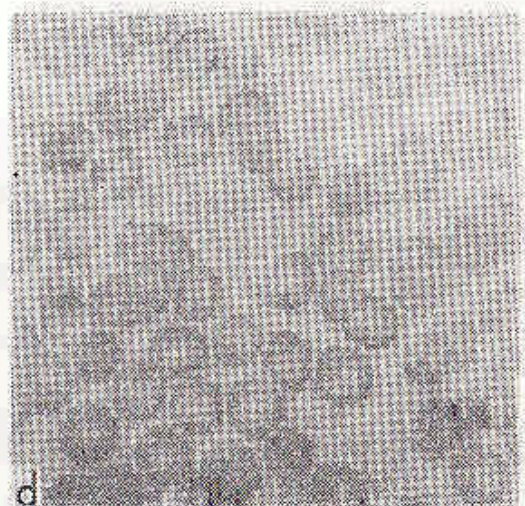
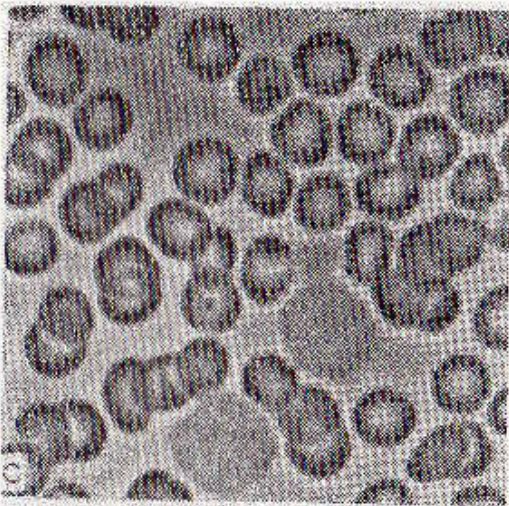
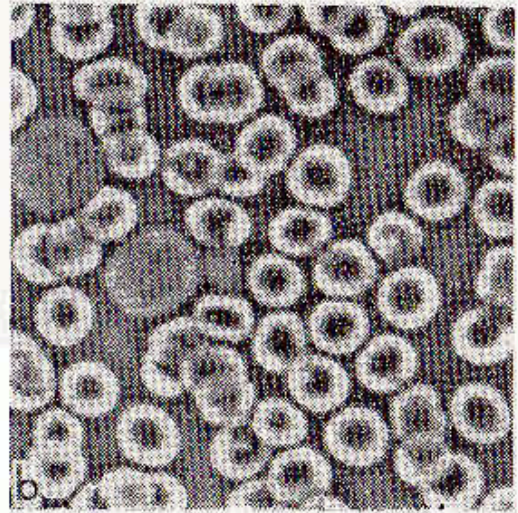
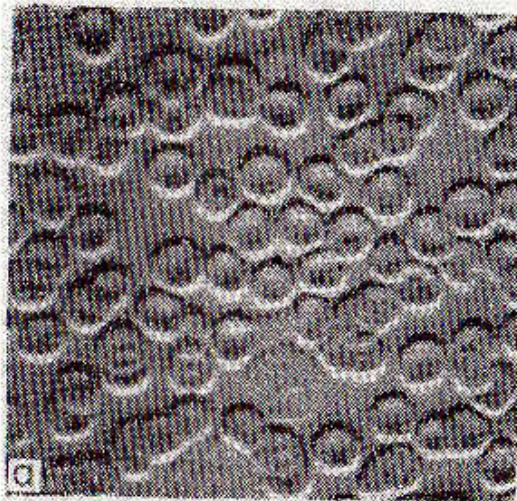

Fig. 52: Blood corpuscles (smear) as seen flooded by a cedar oil
 a) In a uniform differential field (birefringent prism No. 1) polarizing interference microscopy; b) in an anoptical type negative phase contrast microscopy; c) In a positive phase contrast microscopy; d) In an ordinary bright field microscopy with an almost entirely closed iris diaphragm ($\times 40$ object)

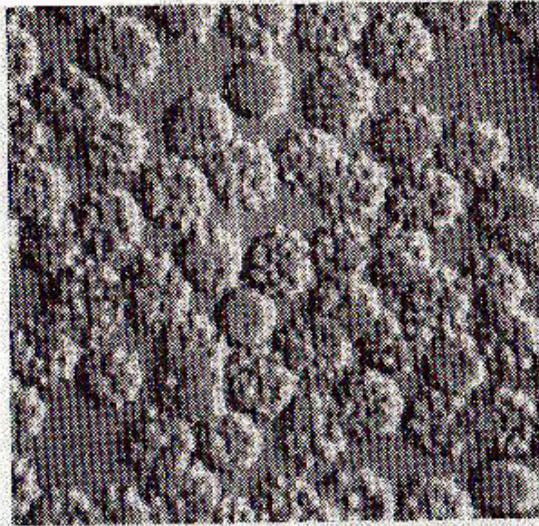

Fig. 53: Red blood corpuscles as seen immersed in an hypertonic aqueous medium through a polarizing interference microscope (uniform differential field method — birefringent prism No. 1)

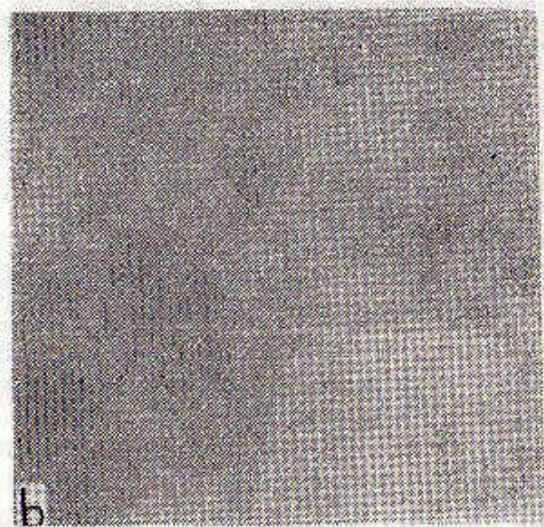
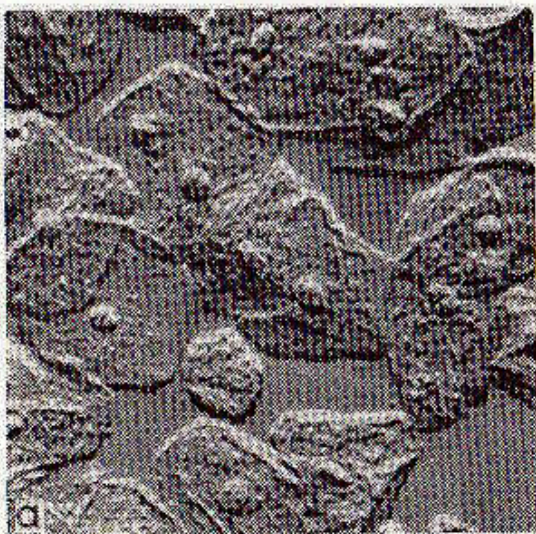

Fig. 54: Epithelial cells from a lip as seen immersed in saliva
a) Uniform differential field polarizing interference microscopy (birefringent prism No. 1); b) Ordinary bright field microscopy ($\times 20$ objective)

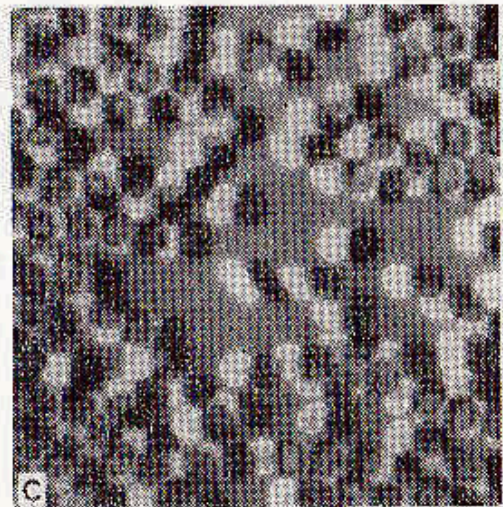
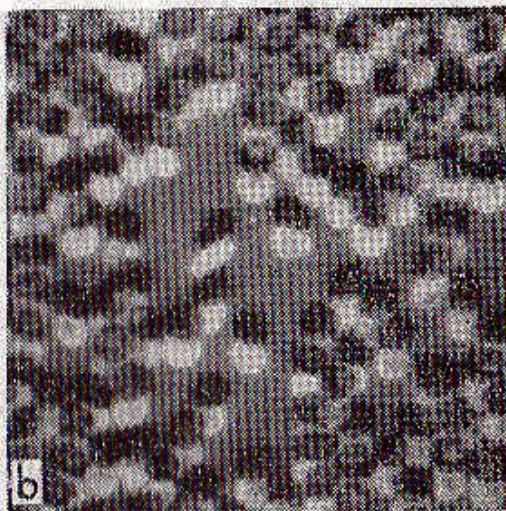
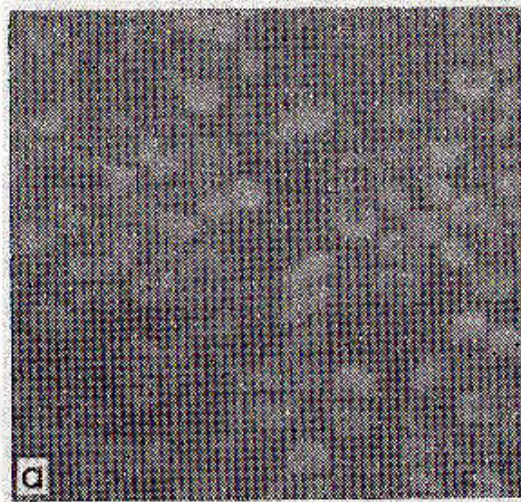

Fig. 55: Red blood corpuscles as seen immersed in cedar oil through a polarizing interference microscope including prism No. 3 (uniform field with a high image shearing effect). Optical path difference measured by darkening images split ($\times 20$ objective)

a) Birefringent prism set for a dark field of view; b) Maximum darkening of R.H. image of corpuscles; c) Maximum darkening of L.H. image

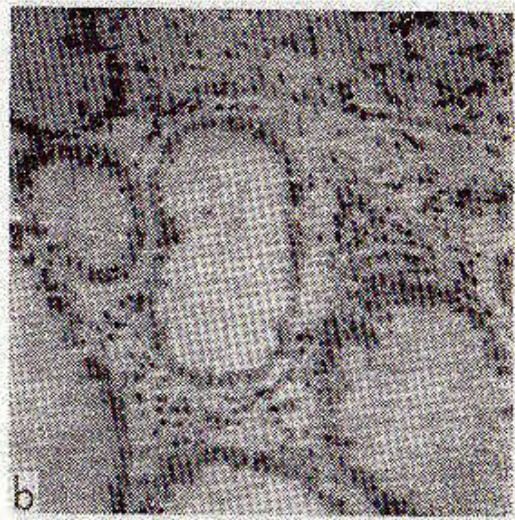
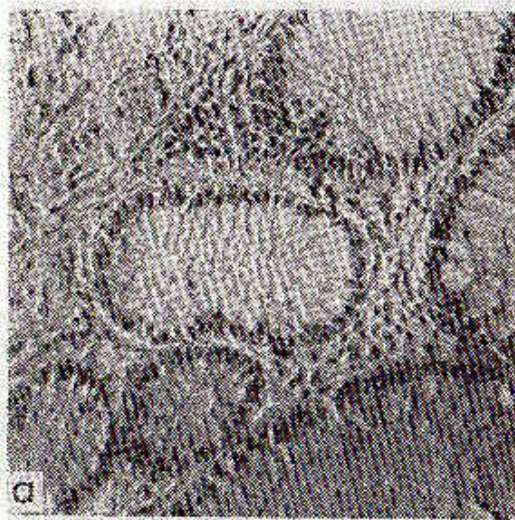

Fig. 56: Image of a histological preparation stained and sealed with the Canada balsam

a) As seen through a polarizing interference microscope in uniform differential field (birefringent prism No. 1); b) As seen through an ordinary bright field microscope ($\times 20$ objective)

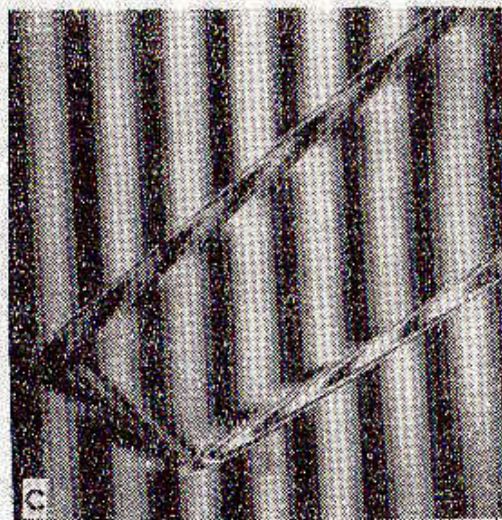
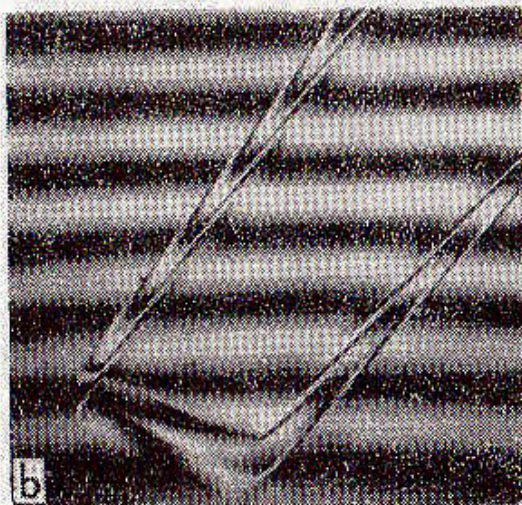
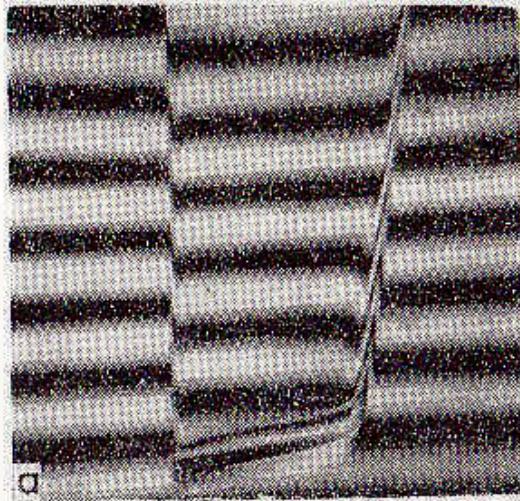

Fig. 57: Image of a birefringent cellophane strip as seen in a fringed interference field

a) Strip with its optical axis set at right angles to the direction of interference fringes; b, c) Strip with its optical axis in parallel and perpendicular alignment versus direction of light vibration in the polarizer (birefringent prism No. 2; $\times 10$ objective)

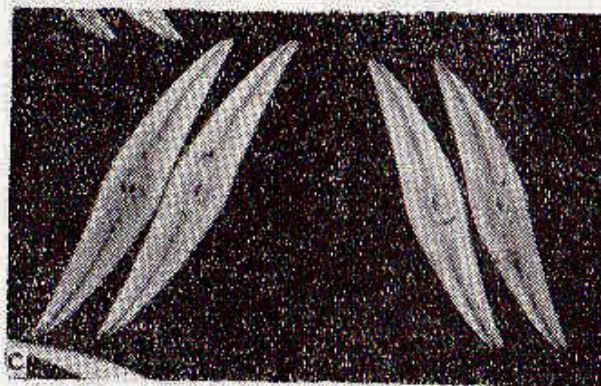
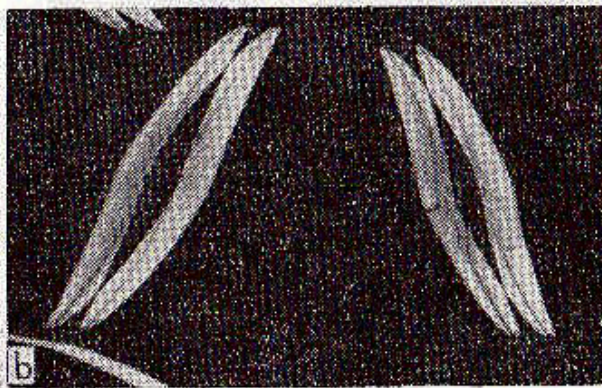

Fig. 58: Image of diatom „Pleurosigma Angulatum” as seen in an uniform interference field with birefringent prism W_2 having different angular positions versus prism No. 3 (W_1)

a) Refracting edge in prism W_2 forms an angle of 45 deg. with that of prism W_1 ;
 b) Direction of refracting angle φ_2 in prism W_2 is opposite versus this of refracting angle φ_1 in prism W_1 ; c) Direction of refracting angle φ_2 in prism W_2 being consistent with that of refracting angle φ_1 in prism W_1

(Objective magnification $\times 10$. Total magnification about $\times 200$)

Chapter 10

ACCESSORIES and PARTS

1. EACH BIOLAR PI POLARIZING AND INTERFERENCE MICROSCOPE IS DELIVERED COMPLETE WITH THE FOLLOWING ITEMS:

It.	Description	Symbols		No. off
		literal	numerical	
1	2	3	4	5
1	Stand	B Zs 1	23080701	1
2	Interference head	UPI Zs 1	25520701	1
3	Centring substage	SK14 Zs 1	27090701	1
4	Eyepiece attachment	MND8 Zs 1	25120701	1
5	Condenser with slit	MPI 3 Zs 3	25510703	1
6	Polarizing interference condenser	KPI 2 Zs 1	26400701	1
7	Polarizer, enclosed	MPI 3 Zs 4	25510704	1
8	Multiple nosepiece	RO4 Zs 1	27500701	2
9	Achromatic $\times 10$ objective	Ob 103C Zs	3529	1
10	Achromatic $\times 20$ objective	Ob 203C Zs	3530	1
11	Achromatic $\times 40$ objective	Ob 404 Zs	3539	1
12	Achromatic $\times 100$ objective	Ob 1003C Zs	3532	1
13	Polarizing interference $\times 10$ objective	Ob 103 PI Zs	3720	1
14	Polarizing interference $\times 20$ objective	Ob 203PI Zs	3721	1
15	Polarizing interference $\times 40$ objective	Ob 403PI Zs	3722	1
16	Polarizing interference $\times 100$ objective	Ob 1003PI Zs	3723	1
17	Huyghenian $\times 8$ eyepiece	OK8H Zs 1	39310701	2
18	Wide field $\times 10$ eyepiece	OK10SK Zs 1	41200701	2
19	Orthoscopic $\times 12.5$ eyepiece	OK7a Zs 0	41300701	2
20	Measuring $\times 12$ eyepiece	OK12MO Zs 1	41380701	1
21	Auxiliary microscope	MPh Zs 1	26320701	1

1	2	3	4	5
22	Interference filter, 546 nm	FI 546 Zs 1	28580701	1
23	Interference filter, 590 nm	FI 590 Zs 1	28590701	1
24	Blue filter	MB30 cz 1-05	23040105	1
25	Green filter	MB30 cz 1-06	23040106	1
26	Yellow filter	MB30 cz 1-07	23040107	1
27	Ground glass	M440 cz 1000	23110101	1
28	Micrometric eyepiece pla- te 10/100	MOL 10/100 cz 1-01	28340101	1
29	Lamp fitting	OS21 Zs 1	26790701	1
30	Lamp 6 V/15 W	OSRAM 8018	0.9.99.0029	5
31	Power supply unit	TM6/50	2926	1
32	Key	B Zs 4	23080704	1
33	Small key	KPI 2 Zs 1-7	26400807	1
34	Condenser key	KPI 5 Zs 2	25860702	1
35	Object micrometer	PPI/100 Zs 1- -01	28310001	1
36	Jar filled with im- mersion oil	SOJ Zs	2874	1
37	Jar filled with XYLOL remover	SZX Zs	2875	1
38	Eyepiece tube cover	ON1 cz 1-1	41561001	2
39	Eye shell	MW1 cz 1-1	28001001	2
40	Soft brush	<u>ZN-57(MPC)</u> 15-01090	0.9.07.0100	1
41	Flannel cloth IA No. 1	<u>ZN-57(MPC)</u> 15-01124	0.9.08.0100	1
42	Container	BPI-FZs	24920750	1
43	Technical description		23922980	1
44	Guarantee card		23922998	1

2. UPI POLARIZING INTERFERENCE EQUIPMENT — ACCESSORIES

It.	Description	Symbols		No. off
		literal	numerical	
1	2	3	4	5
1	Interference head	UPI Zs 1	25520701	1
2	Condenser with slit	MPI 3 Zs 3	25510703	1
3	Polarizing interference condenser	KPI 2 Zs 1	26400701	1
4	Multiple nosepiece	RO4 Zs 1	27500701	1
5	Polarizing interference ×10 objective	Ob 103 PI Zs	3720	1
6	Polarizing interference ×20 objective	Ob 203 PI Zs	3721	1
7	Polarizing interference ×40 objective	Ob 403 PI Zs	3722	1
8	Polarizing interference ×100 objective	Ob1003 PI Zs	3723	1
9	Polarizer, enclosed	MPI 3 Zs 4	25510704	1
10	Measuring ×12 eyepiece	OK12MO Zs 1	41380701	1
11	Auxiliary microscope	MPh Zs 1	26320701	1
12	Interference filter, 546 nm	Fi 546 Zs 1	28580701	1
13	Interference filter, 590 nm	Fi 590 Zs 1	28590701	1
14	Micrometric eyepiece plate 10/100	MOL 10/100 cz 1-01	28340101	1
15	Standard plate	PPI/100 Zs 1- -01	28310001	1
16	Key	KPI 2 Zs 1-7	26400807	1
17	Condenser key	KF15 Zs 2	25860702	1
18	Soft brushes	<u>ZN-57/MPC</u> 15-01090	0.9.07.0100	1
19	Flannel cloth IA No. 1	<u>ZN-57/MPC</u> 15-01124	0.9.08.0100	1
20	Container	UPI-F Zs	25520750	1
21	Technical description		23922980	1
22	Guarantee card		25522998	1

3. OUTFIT FOR A BIOLAR PI MICROSCOPE OR POLARIZING INTERFERENCE UPI EQUIPMENT — OPTIONAL ACCESSORIES

Description	Literal symbol	Numerical symbol	No.
Refractometric plates	PRF Zs	4154	1
Microscope attachment with a penumbra eyepiece (half-shade)	MNOP Zs	2487	1
Planachromatic $\times 10$ objective	Ob 108 Zs	3620	1
Planachromatic $\times 20$ objective	Ob 208 Zs	3627	1
Planachromatic $\times 40$ objective	Ob 408 Zs	3622	1
Planachromatic $\times 100$ objective	Ob 1008 Zs	3623	1
Plancompensating eyepiece $\times 8$	Ok 8 Pk Zs1	39780701	2
Plancompensating eyepiece $\times 16$	Ok 16 PK Zs1	39790701	2
Microscope photographic attachment 6.5 \times 9 cm	MNF Zs	2560	1
Microscope photographic attachment 24 \times 36 mm	MNFA Zs	2566	1
Adaptor for EXACTA and VAREX cameras	MNF Zs 8	25600706	1
Adaptor for PRACTICA and CONTAX cameras	MNF Zs 10	25600707	1
Adaptor for LEICA and ZORKI cameras	MNF Zs 12	25600708	1
Halogen illuminator	OH Zs	2680	1
Microscope projector lens	MNP1 Zs	2541	1
Microscope drawing eyepiece	MOR Zs	2534	1
Monocular eyepiece	MNJ5 Zs	2490	1
Mechanical rotary stage	SO7 Zs	2717	1
Centring substage	NK6 Zs	2733	1

Refractometric plates (or slides) are designed to measure refractive index in liquids. For their construction and measuring procedure refer to Chapter 6 It. 4.

Microscope penumbra eyepiece MNOP has been designed to step up accuracy and to improve measurement technique of optical path difference when using uniform field method with a high image shearing effect. Optical path difference can in this case be measured with an almost twice as high accuracy as before, i.e. an accuracy of $\lambda/500$. For measurement procedure refer to Chapter 5 It. 2.

Planachromatic objectives with compensating eyepieces ensure that highest quality microscopic image can be achieved throughout the entire field of view. With the planachromatic objectives used on a BIOLAR PI microscope one can endeavour to carry out all the described measurements without producing an additional shearing effect. Planachromatic objectives must be ordered together with the compensating eyepieces.

Microphotography equipment enables miniature photographs of small objects for being taken on 6.5×9 cm glass plates, 6×9 cm cut films and 24×36 mm rolled films.

MNF — Photographic attachment for taking photographs of microscopic preparations on 6.5×9 cm plates or films.

Focusing process includes observation of image in the image sharpness setter (photographic attachment peep-hole). Exposure time represents a manual adjustment.

MNFA — Photographic attachment for taking photographs of microscopic preparations on 24×36 mm rolled films. Focusing and exposure time setting as the MNF item.

Both these attachments, and MNFA in the first place, are made available with the following adaptors for use with the cameras, as follows:

EXACTA-VAREX: adaptor MNF Zs 8

PRACTICA & CONTAX: adaptor MNF Zs 10

LEICA and ZORKI: adaptor MNF Zs 12

These adaptors are delivered as optional items of the MNF and MNFA equipment and for this reason they are supplied on customer's request packed separately so as to suit the type of camera owned by him.

Halogen illuminator OH with a halogen 100 W/12 V lamp can be used instead of a filament type illuminator when a stronger source of light is required, e.g. in microphotography, drawing and similar practices.

Microscope projector lens MNP1 finds primarily use in didactics. With its aid several people can observe, at a time, one and the same microscopic image on a screen. Screen is 140 mm in diameter with ×8 and ×12.5 magnification of the lens itself.

Through the use of HO halogen illuminator adequate brightness can be adopted for the image being viewed.

Microscope drawing eyepiece MOR has been designed to enable contouring of objects viewed through the microscope with a simultaneous observation of the specimen and pencil end in motion.

Whenever required, an eyepiece micrometer can be inserted inside to measure the specimen. Eyepiece control is movable within a span such as to ensure dioptric adjustment from — 4 to +3 diopters.

Eyepiece magnification is ×10.

MOR has been designed for use with only monocular MNJ5 eyepieces.

Monocular eyepiece MNJ5 in the eyepiece tube axis can be swung back from vertical through an angle of 55 deg. Magnification $\times 1$.

Mechanical rotary stage SO7 has been designed for applications where a rotation of the stage through $\pm n \cdot 360$ degrees and its accurate positioning in the desired angular setting are required. Especially suitable for polarized light examinations. The NK6 centring substage can be added to said stage, if necessary.

Two adjustment screws and keys are provided to enable axial alignment of the stage versus microscope centre line. Accuracy of angular readings — 0.1° . A ratchet device has been added to enable positioning of the upper plate every 45 ± 1 degrees.

Centring substage NK6 can be fitted on stage SO7. It renders possible mechanical movement of the specimen in the mutually perpendicular directions within a range of 25×75 mm.

Table I

**INTERFERENCE COLOURS FOR OPTICAL PATH DIFFERENCES
BETWEEN ORDINARY AND EXTRAORDINARY WAVES**

Optical path difference in nm	Polarizer and analyser crossed	Polarizer and analyser in parallel alignment
1	2	3
00	Black	White
40	Metallic grey	White
97	Lavender grey	Yellowish white
158	Greyish blue	Yellowish pale
218	Clearer grey	Yellow-brown
234	Greenish white	Brown
259	White	Bright red
267	Yellowish white	Carmine-red
275	Pale straw yellow	Red-brown
281	Straw yellow	Dark violet
306	Bright yellow	Indigo
332	Vivid yellow	Blue
430	Brown-yellow	Grey-blue
505	Red-orange	Bluish green
536	Warm red	Pale green
551	Deep red	Yellowish green
565	Purple	Bright green
575	Violet	Greenish yellow
589	Indigo	Golden yellow
664	Sky blue	Orange
728	Blue	Brown-orange
747	Greenish green	Carmine-red
826	Bright green	Bright purple
843	Yellowish green	Violet-purple
866	Greenish yellow	Violet
910	Clear yellow	Indigo
948	Vivid orange	Dark blue
998	Orange-red	Greenish blue
1101	Dark red	Green
1128	Violet-blue, bright	Yellowish green
1151	Indigo	Yellow-brown
1258	Greenish shade blue	Flesh colour
1334	Sea-green	Brown-red
1376	Brilliant green	Violet

**TECHNICAL SPECIFICATION
OF A BIOLAR PI MICROSCOPE**
(Approximate data)

		BIREFRINGENT PRISM			BIREFRINGENT PRISM			BIREFRINGENT PRISM				
		No. 1 (Differential type)			No. 2 (Fringe type)			No. 3 (Uniform field of view high image shearing)				
INTER-FRINGE SPACING h (in micrometers μm)	LIGHT COLOUR:											
	GREEN $\lambda=546 \text{ nm}$	2500 μm	190 μm	760 μm								
	YELLOW $\lambda=590 \text{ nm}$	2750 μm	205 μm	830 μm								
	WHITE $\lambda=550 \text{ nm}$	2550 μm	193 μm	770 μm								
MAXIMUM IMAGE SHEARING EFFECT RELATED TO OBJECT PLANE (in micrometers μm) — prism W_1	OBJECTIVE MAGNIFYING POWER											
		$\times 10$	$\times 20$	$\times 40$	$\times 100$	$\times 10$	$\times 20$	$\times 40$	$\times 100$	$\times 10$	$\times 20$	$\times 40$
	1,84	0,98	0,5	0,2	32	17	8,7	3,4	6,45	3,45	1,75	0,70
— prism W_1+W_2	40	20	12	4	70	37	29	8	45	23	14	5

Table II



condt. Table No. 1

	BIREFRINGENT PRISM No. 1 (Differential type)	BIREFRINGENT PRISM No. 2 (Fringe type)	BIREFRINGENT PRISM No. 3 (Uniform field of view high image shearing)
VALUE OF CONSTANT p' (in micrometers μm)		200 μm	
— prism W_1 in top position (prism W_2 not of operation)			
— for prism $W_1 + W_2$		430 μm	
RANGE OF MEASUREMENT FOR OPTICAL PATH DIFFERENCE (EXPRESSED IN LIGHT WAVELENGTH)	3 λ	$\pm 25 \lambda$	$\pm 5 \lambda$
ACCURACY OF MEASUREMENT FOR OPTICAL PATH DIFFERENCE	$\lambda/250$	$\lambda/30$	$\lambda/80$
ACCURACY OF MEASUREMENT FOR OPTICAL PATH DIFFERENCE	$\pm 1\%$ FOR LIGHT TRANSMITTANCE FROM 0 TO 70%		

FOR GREEN LIGHT
($\lambda = 546 \text{ nm}$)

Table III

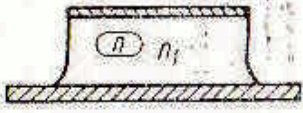
KEY TO ESTIMATE REFRACTIVE INDEX OF MICRO-OBJECTS AND SURFACE IRREGULARITIES *)

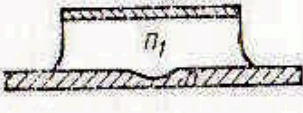
SHAPE	REFRACTIVE INDEX	DIFFERENTIAL METHOD (PRISM No. 1)	UNIFORM FIELD METHOD WITH HIGH IMAGE SHEARING EFFECT (PRISM No. 3)	FRINGE METHOD (PRISM No. 2)	
		Peculiarity to identify method being used			
		Direction in which dark colour is being displaced	Sequence of extinction for images split	Extinction of images split	
 or  (Hill)	$n > n_1$	Consistent with that of birefringent prism displacement	Consistent with the direction of birefringent prism displacement	LH image darkening on RH side of dark fringe whereas RH image on its LH side	
	$n < n_1$	Opposite versus that of birefringent prism displacement	Opposite versus that of birefringent prism displacement	LH image darkening on LH side of dark fringe whereas RH image on its RH side	
 (Valley)	$n > n_1$	Opposite versus that of birefringent prism displacement	Opposite versus that of birefringent prism displacement	LH image darkening on LH side of dark fringe whereas RH image on its RH side	
	$n < n_1$	Consistent with that of birefringent prism displacement	Consistent with the direction of birefringent prism displacement	LH image darkening on RH side of dark fringe whereas RH image on its LH side	

*) NOTE: True for prisms $W_1 W_2$ (Fig. 9) having an identical position and for prism W_2 having a neutral position.

BIBLIOGRAPHY

1. Barer R.: *Determination of dry mass, thickness, solid and water concentration in living cells*. NATURE, vol. 172 (1953), p. 1097.
2. Barer R.: *Interference microscopy and mass determination*. NATURE, vol. 169 (1952), p. 336.
3. Barer R.: *Refractometry and interferometry of living cells*. Journ. Opt. Soc. Am., vol. 147 (1957), p. 545.
4. Barer R.; Dick D.A.T.: *Interferometry and refractometry of cells in tissue culture in cytochemical methods with quantitative aims*. Exp. Cell Res., Suppl., vol. 4 (1957), pp. 103—135. Academic Press Inc., New York (1957).
5. Chłap Z., Mirek T.: *Utilisation en cytodagnostic du microscope interférentiel à polarisation pour déterminer la masse sèche des cellules*. Revue Cytologie Clinique; vol. 2, No. 4 (1969), p. 23-2.
6. Darżynkiewicz Z., Jurkova Z., Więckowski J.: *Interferometric measurements of the alkaline phosphatase activity in epithelial cell from the vagina of mice in the course of the keratinization process*. Bull.Acad.Pol.Sci., vol. 13 (1956), p. 275.
7. Darżynkiewicz Z., Więckowski J.: *Use of interference microscopy for quantitative estimation of alkaline phosphatase activity in Ehrlich ascites tumor cells*. Folia Histochemica et Cytochemica. Vol. 3 (1965), p. 275.
8. Darżynkiewicz Z., Dokov V.K., Pieńkowski M.: *Dry mass of lymphocytes during transformation after stimulation by phytochaemagglutinin*. NATURE (London), vol. 214 (1967), pp. 1265—1266.
9. Devies H.G., Deeley E.M.: *An integrator for measuring the „dry mass” of cells and isolated components*. Exp. Cell Res., vol. 11 (1956), pp. 169—185.
10. Devies H.G., *The determination of mass and concentration by microscope interferometry*. General Cytochemical Methods, F.J. Danielli, Academic Press, New York (1958), p. 55.