

Nikon

Biological Microscope
LABOPHOT
(Y-R stand) *Later model with
Reversed Nosepiece*

INSTRUCTIONS

NIKON CORPORATION

CAUTIONS

1 Avoid sharp knocks!

Handle the microscope gently, taking care to avoid sharp knocks.

2 When carrying the microscope

When carrying the microscope, hold its arm with one hand, supporting the bottom of the microscope base with the other. The instrument weighs about 8 kg.

3 Place for using

Avoid the use of the microscope in a dusty place, where it is subject to vibrations or exposed to high temperatures, moisture or direct sunlight.

4 Light source

Use halogen lamp 6V – 20W.

5 In lighting the lamp

Take care not to touch the rear cover of the lamp being lighted, and don't bring inflammable substances such as gasoline, thinner, and alcohol near to the cover, as it may take a high temperature while the lamp is being lighted.

6 Exchanging the lamp bulb and fuse

Before replacing the lamp bulb (6V – 20W) or fuse, turn OFF the power switch and disconnect the plug of the power source cord.

In such cases as of replacement, do not touch the lamp bulb with bare hands, immediately after putting out the lamp.

7 Dirt on the lens

Do not leave dust, dirt or finger marks on the lens surfaces. They will prevent you from clear observation of the specimen image.

8 Focus knobs

Never attempt to adjust the tightness of the right- and lefthand focus knob by turning the one, while holding the other in this model microscope, because of causing disorder.

CARE AND MAINTENANCE

1 Cleaning the lenses

To clean the lens surfaces, remove dust using a soft brush or gauze. Only for removing finger marks or grease, should soft cotton cloth, lens tissue or gauze lightly moistened with absolute alcohol (ethyle alcohol or methyl alcohol) be used. For cleaning the objectives and immersion oil use only xylene.

For cleaning the surface of the entrance lens of the eyepiece tube and the prism surface of the Trinocular Eyepiece Tube "T" or the Ultra Wide Eyepiece Tube "UW", use absolute alcohol.

Observe sufficient caution in handling alcohol and xylene.

2 Cleaning the painted surfaces

Avoid the use of any organic solvent (for example, thinner, ether, alcohol, xylene etc.) for cleaning the painted surfaces and plastic parts of the instrument.

3 Never attempt to dismantle !

Never attempt to dismantle the instrument so as to avoid the possibility of impairing the operational efficiency and accuracy.

4 When not in use

When not in use, cover the instrument with the accessory vinyl cover, and store it in a place free from moisture and fungus.

It is especially recommended that the objectives and eyepieces be kept in an air-tight container containing desiccant.

5 Periodical checking

To maintain the performance of the instrument, we recommend to check the instrument periodically. (For details of this check, contact our agency.)

CONTENTS

I. NOMENCLATURE	4
II. ASSEMBLY	6
III. MICROSCOPY	8
1. Operating Procedure	8
2. Manipulation of Each Element	9
1) Interpupillary distance adjustment	9
2) Diopter adjustment	9
3) Optical path change-over in the trinocular eyepiece tube	9
4) Centering the condenser lens	10
5) Use of condenser aperture diaphragm	10
6) Use of field diaphragm	11
7) Focusing	11
IV. OPTICAL SYSTEM	12
V. PHOTOMICROGRAPHY	16
VI. USE OF THE ACCESSORIES	19
VII. TROUBLE SHOOTING TABLE	21
1. Optical	21
2. Manipulation	22
3. Electrical	23
4. Photomicrography	23
ELECTRIC SPECIFICATIONS	27

I . NOMENCLATURE

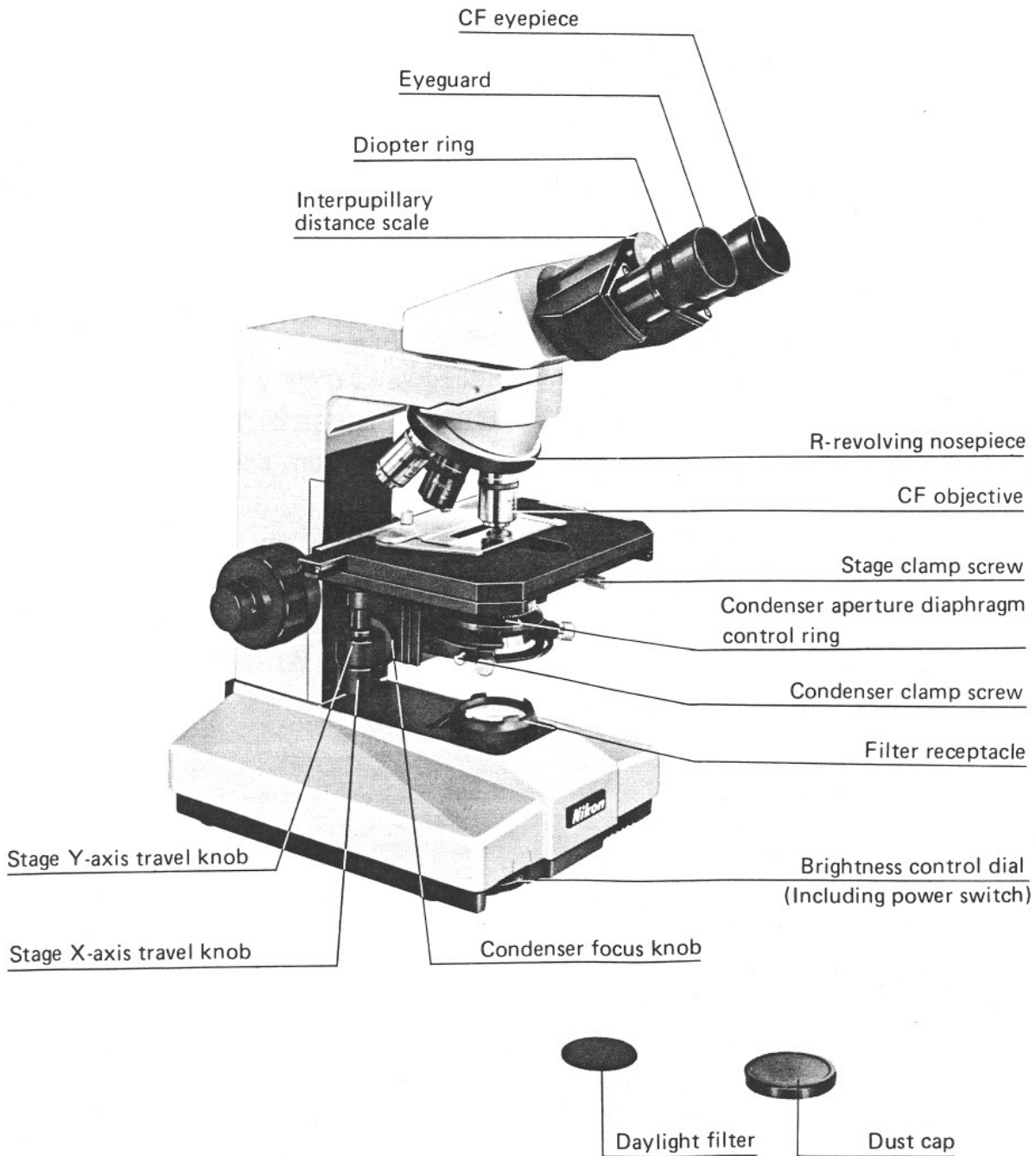

Fig. 1

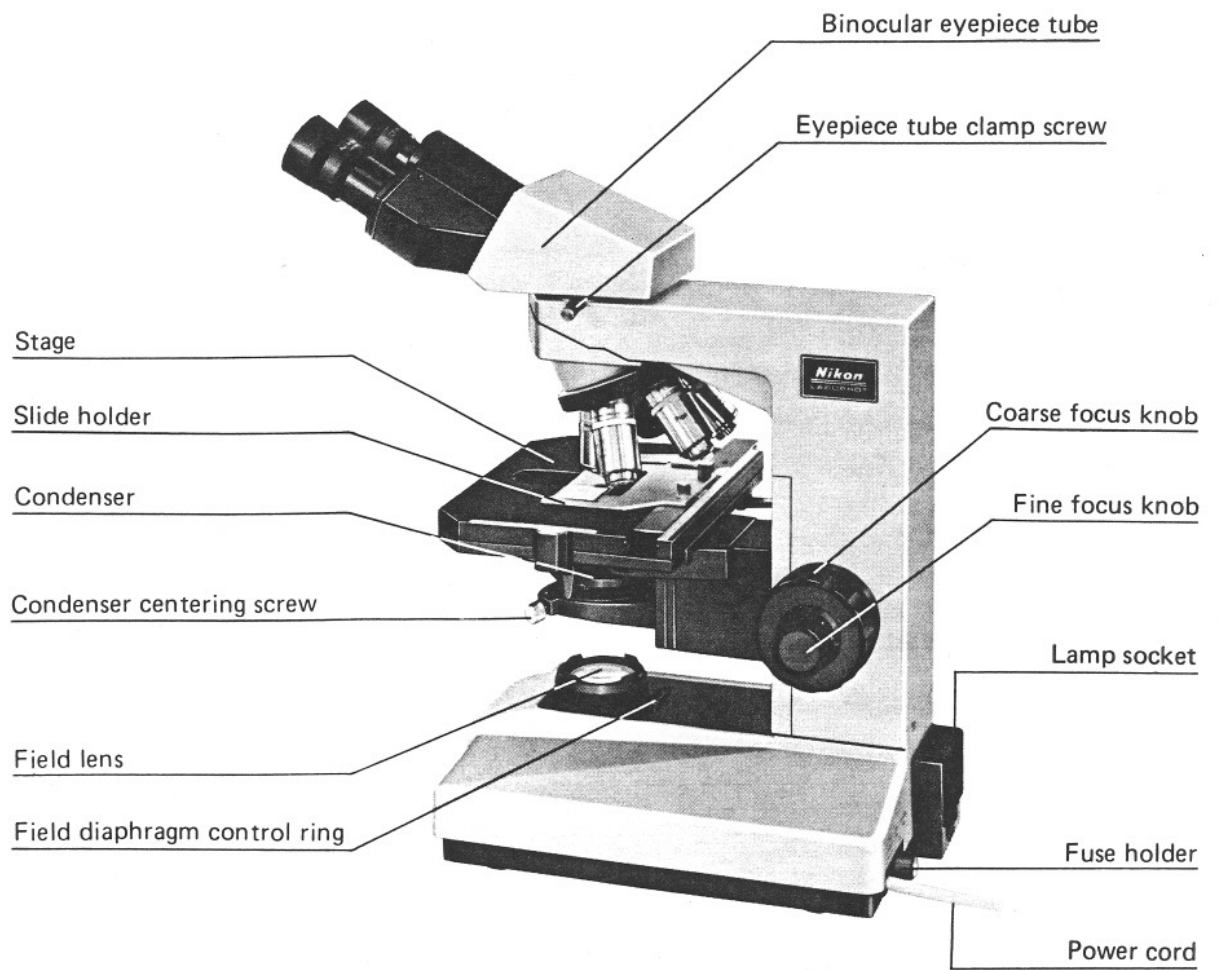

Fig. 2

II. ASSEMBLY

- To assemble the microscope, follow the procedure in the order given:

① Leveling foot screw

For stable installation of the microscope, manipulate the adjusting screw at one foot on the bottom of the microscope base.

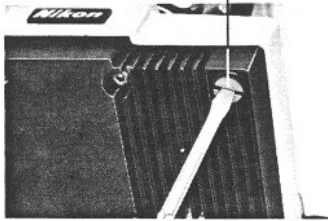

② Lamp bulb

Insert the lamp bulb with its pins into the accepting hole in the socket.
Note: Don't touch the bulb surface directly with the fingers.



③ Lamp socket

Insert the socket into the receptacle on the microscope base.



⑨ Daylight filter

Place the filter on the field lens. 45 mm in diameter.

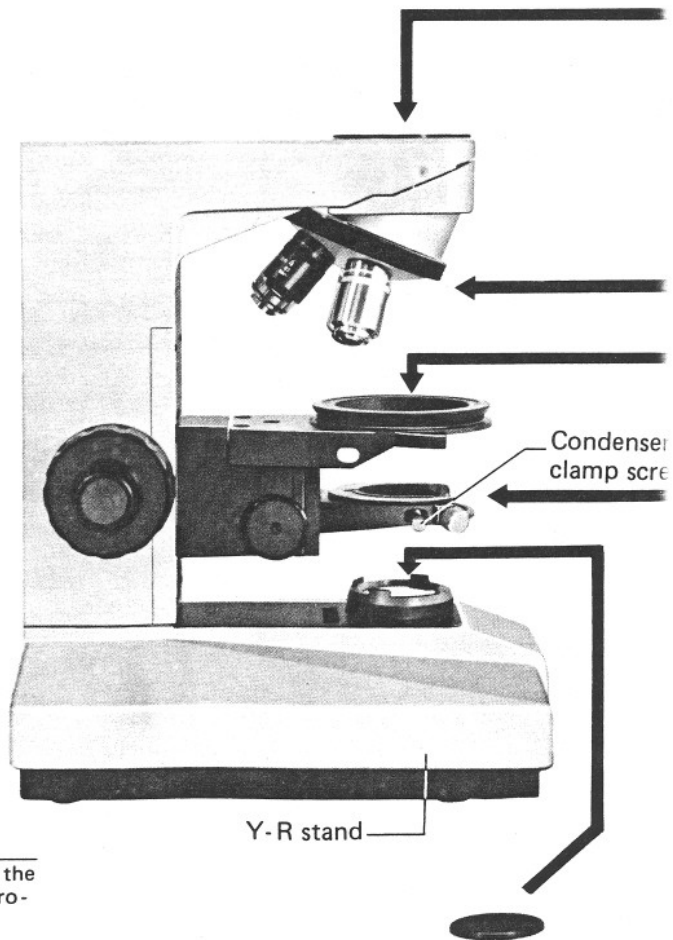

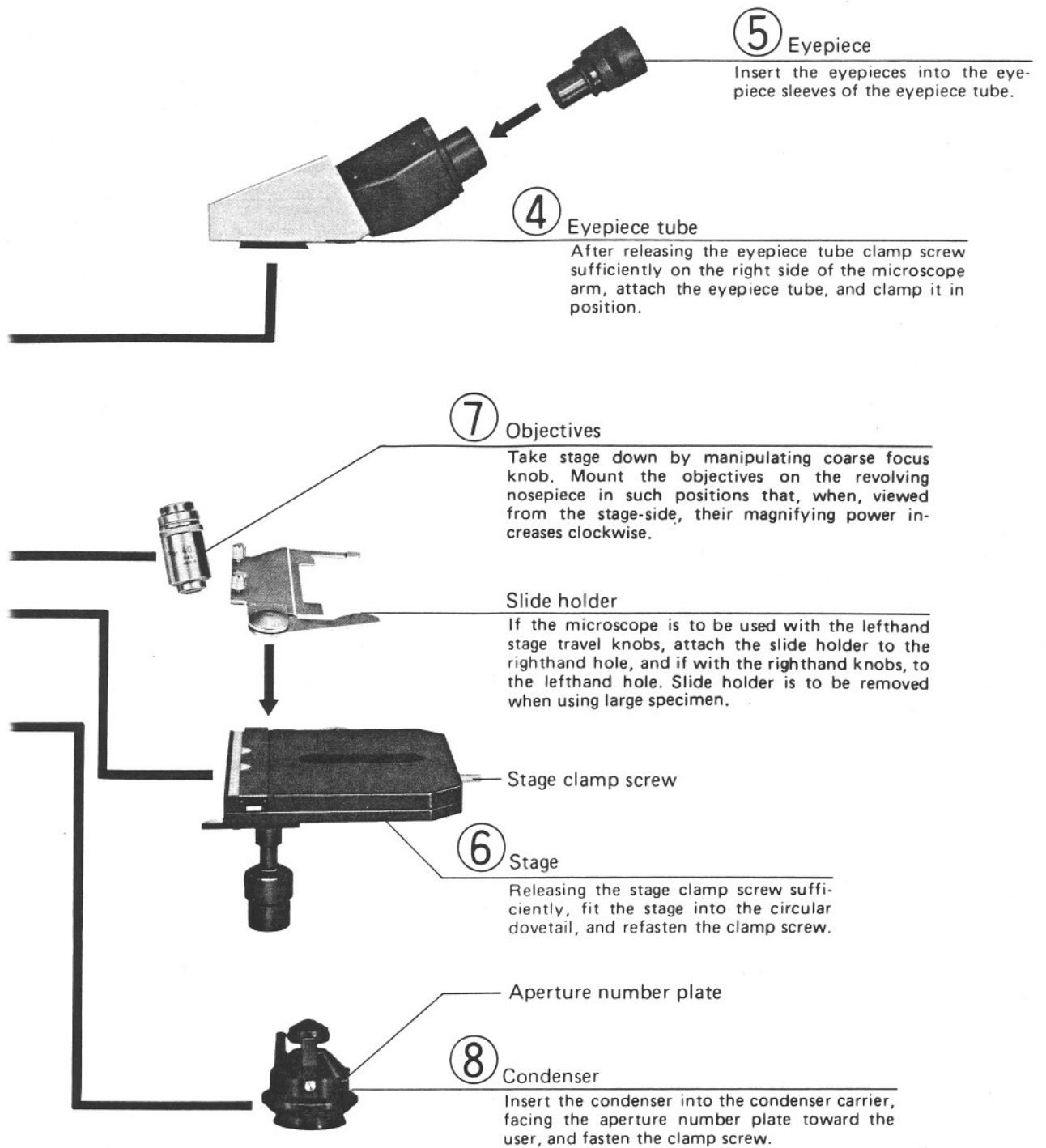

Fig. 3

III. MICROSCOPY

1. Operating Procedure

- 1) Turn the brightness control dial (including power switch) to ON and set the scale on the dial to 4.
- 2) Remove the dust cap and place the daylight filter onto the field lens.
- 3) Place the specimen on the stage and swing the 10× objective into position. Focus on specimen.
- 4) Adjust the interpupillary distance and diopter. (Refer to P. 9)
- 5) Carry out the centering procedure for the condenser. (Refer to P. 10)
- 6) Swing in the objective to be used and refocus on specimen.
- 7) Adjust the condenser. (Refer to Table 1)

Table 1. Use of Condensers

Type of condenser	Abbe condenser	Swing-out Achromat condenser	Achromat/aplanat condenser
Object distance	N.A. = 1.25	N.A. = 0.9 Dry system	N.A. = 1.35 Oil-immersion
Objective	2mm	1.8mm	1.6mm
1×	Remove the condenser	Remove the condenser	Remove the condenser
* 2×		Top lens swung out	
* 4×	Usable	Top lens swung in	Usable
10×			
20× 40× 100×			

[NOTE] ● The above object distance (from the top of the condenser lens to the specimen surface) includes a glass slide thickness 1.2mm.

- * ● When using the Swing-out condenser with 2× or 4× objective, fully open its aperture diaphragm.
- UW (ultra-wide) viewfield observation is possible with 2× ~ 100× objective. In combination with the Abbe condenser, however, the use of the 10× or higher objective is possible.
- For photomicrography using the 4× or lower objective, remove the Abbe condenser.
- For photomicrography using the 2× objective, preferably remove the condenser.
- For observation with the 1× objective, additionally use the diffuser. (available on order).
- The Achromat/aplanat condenser is not included in the standard set.

- 8) Brightness is adjusted by changing the lamp voltage.
- 9) Adjust the condenser aperture diaphragm and the field diaphragm. (Refer to P. 10, 11)

2. Manipulation of Each Element

1) Interpupillary distance adjustment

Place a specimen on the stage, and focus on the specimen. As shown in Fig. 4, adjust the interpupillary distance, so that both the right and left viewfields become one.

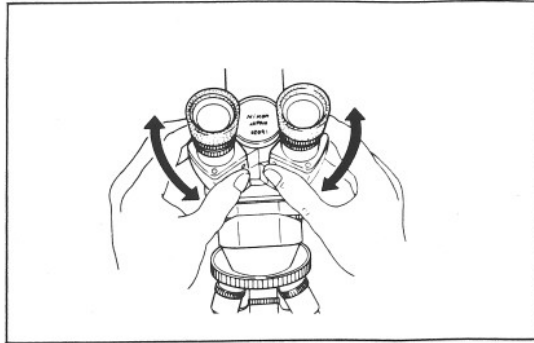

Fig. 4

2) Diopter adjustment

Make diopter adjustment for both the right and lefthand eyepieces.

- (1) Turn the diopter ring on each eyepiece, until the end surface of the milled ring coincides with the engraved line, as shown in Fig. 5.

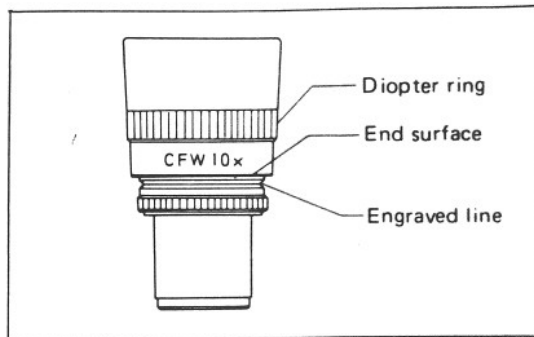

Fig. 5

- (2) Mount the specimen on the stage. Swing the objective 40X into position, and bring the specimen image into focus. For facilitating the focusing, first use the 10X and then 40X objective.
- (3) Thereupon, swing the objective 4X into position.

Without manipulating the coarse and fine focus knob, turn the diopter rings on the eyepieces, so that the specimen images in the right and lefthand eyepieces are focused individually.

- Repeat the above procedure two times, and a perfect diopter adjustment will be achieved.
 - The above adjustment, compensating the diopter difference between the user's right and left eyes, will keep the tube length of microscope correct, thus enabling him to realize the full advantages of the highclass objectives, including their parfocality.
- (4) Since the CF eyepieces are of high eyepoint type, it is not necessary for the user putting on his spectacles to remove them.

Only fold down the eyeguard rubber.

(Fig. 7)

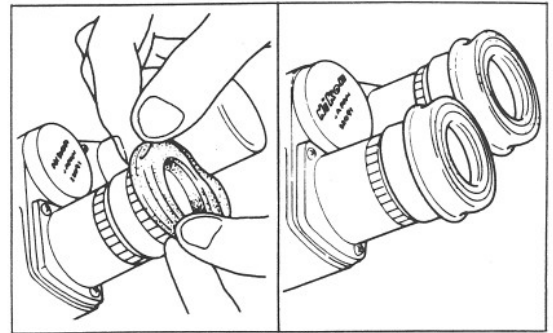

Fig. 6

Fig. 7

3) Optical path change-over in the trinocular eyepiece tube

- (1) When using the trinocular eyepiece tube "F"

As shown in Fig. 8, when the observation tube is turned toward the user, 100% of light enters the observation tube.

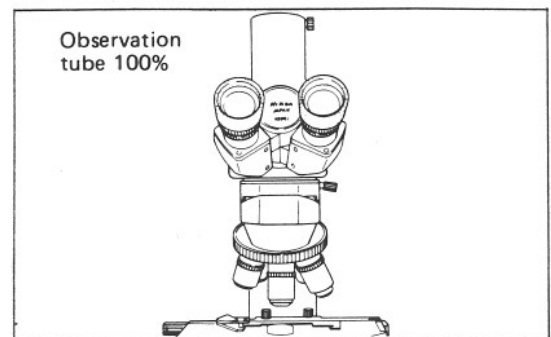

Fig. 8

As shown in Fig. 9, when the observation tube is revolved 60° leftward, 100% of light enters the vertical photo tube.

In either case, turn the tube to the limit.

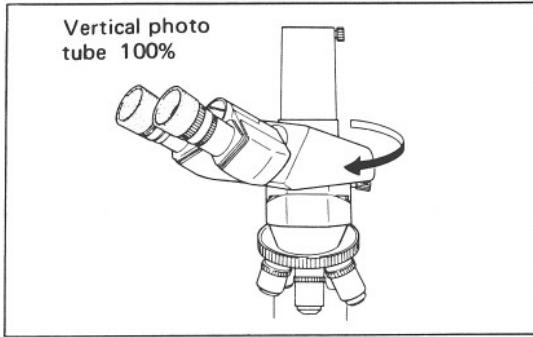

Fig. 9

- (2) When using the trinocular eyepiece tube "T" or the ultra wide eyepiece tube "UW"

As shown in Fig. 10, with the change-over knob pushed in, 100% of light enters the observation tube.

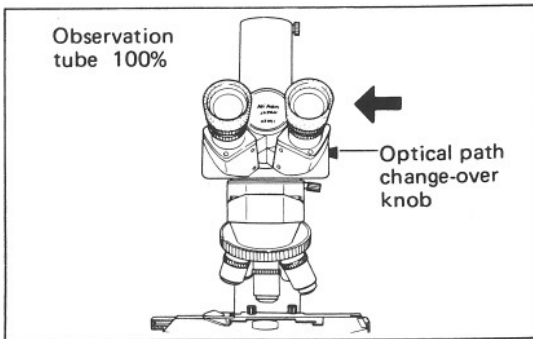

Fig. 10

As shown in Fig. 11, with the change-over knob drawn out, the proportion of light entering the binocular observation tube and vertical photo tube will be 14 : 86.

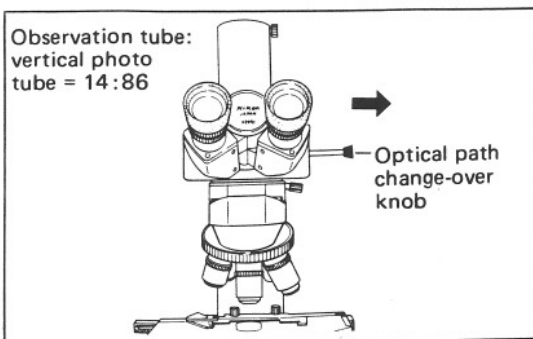

Fig. 11

4) Centering the condenser lens

- (1) Close the field diaphragm in the microscope base to its smallest size by means of the field diaphragm control ring. Rotate the condenser focus knob to move the con-

denser vertically so that a sharp image of the field diaphragm is formed on the specimen surface.

- (2) Bring the field diaphragm image to the center of the field of view by means of the condenser centering screws. (Fig. 12-1)
- (3) Change over to the 40X objective, and adjust the field diaphragm so that the image of the diaphragm is about the same as that of the field of view, as shown in Fig. 12-2. If not centered, use the condenser centering screws again.

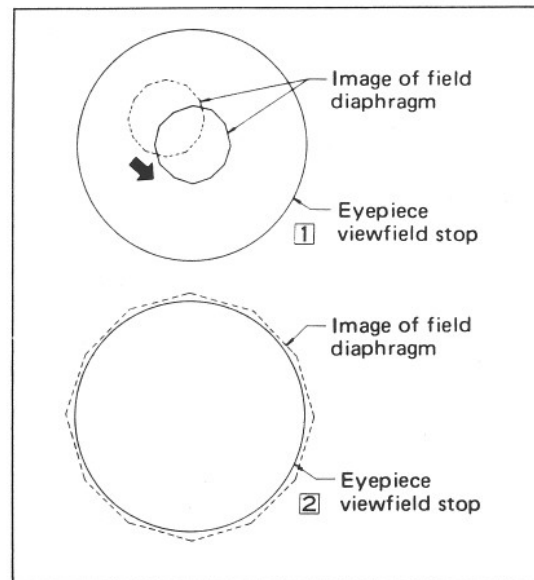

Fig. 12

5) Use of condenser aperture diaphragm

The condenser aperture diaphragm is provided for adjusting the numerical aperture (N.A.) of the illuminating system of microscope. It is important because it determines the resolution, contrast and depth of focus.

In general, when it is stopped down to 70 ~ 80% of the numerical aperture of the objective, a good image of appropriate contrast will be obtained. (Fig. 13)

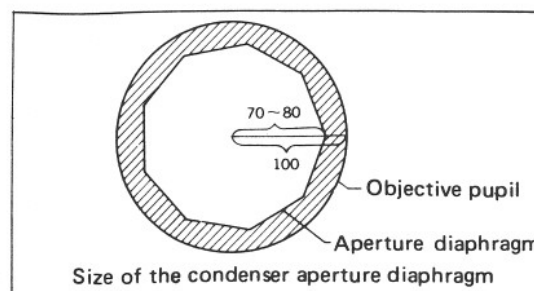

Fig. 13

The graduation on the Abbe condenser indicates the diameters in mm of the aperture diaphragm opening of condenser.

After removing the eyepiece from the eyepiece tube, adjust the size of the diaphragm, observing the image of the diaphragm which is visible on the bright circle of exit pupil of objective inside.

It is recommended to take note of the diameter of the diaphragm opening for each objective power, whereby the best image is obtained.

The Swing-out Achromat and Achromat/aplanat condensers, however, have a graduation indicating the numerical apertures (N.A.), and not the diameters of diaphragm opening.

Manipulation of these condensers is the same as that of the Abbe condenser. Stopping down the aperture diaphragm too far will deteriorate the image quality of microscope due to diffraction of light. Therefore, it is not recommended to stop down the aperture to a size smaller than 60% of the N.A. of the objective in use except when observing almost transparent specimen.

6) Use of field diaphragm

The field diaphragm is used for determining the illuminated area on the specimen surface in relation to the field of view of the microscope. Generally, it is stopped down to such an extent that the circumference of the illuminated area circumscribes or inscribes that of the eyepiece field of view. If the former be larger than the latter, extraneous light will enter the field of view, causing flare in the image and lowering the contrast. Therefore, especially in photomicrography, the proper adjustment of the field diaphragm is very important. Generally, good results will be achieved when the diaphragm is stopped down to such an extent that the diameter of illuminated area is slightly larger than the diagonal of film format.

7) Focusing

The relation between the direction of rotation of the focus knobs and that of vertical movement of the stage is as indicated in Fig. 14.

One rotation of the fine focus knob moves the stage 0.2mm.

The graduation on this focus knob is divided into 2 μ m.

One rotation of the coarse focus knob moves

the stage 4.7mm.

The range of coarse and fine motion is within 30mm; 2mm up and 28mm down from the standard position.

Tightness of the coarse-fine focus knob having been properly adjusted by the manufacturer, it should never be readjusted in this model microscope by turning the one knob while holding the other.

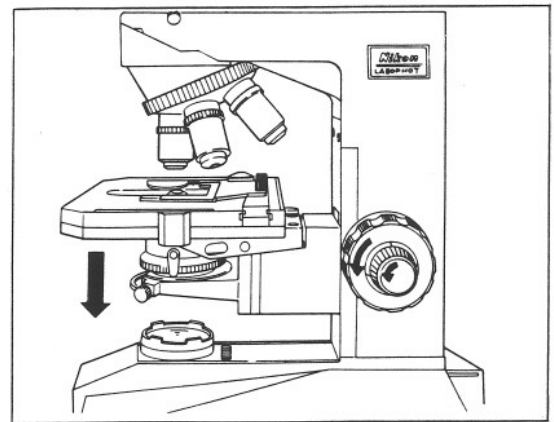

Fig. 14

IV. OPTICAL SYSTEM

The CF objectives and CF eyepieces adopted in the Nikon Biological Microscope LABOPHOT are designed on the basis of a new Nikon-developed concept "Chromatic Aberration Free" With the Nikon CF optical system the chromatic difference of magnification in the objective and eyepiece is individually corrected. This is unlike conventional microscopes where the corrections of such aberration has been, for the most part, compensated for in the objectives and eyepiece as a pair. As a result the Nikon Microscope LABOPHOT has no orange colored fringe in the eyepiece. In cooperation with the other optimum aberration corrections such as the Nikon Integrated Coating, a uniformly sharp image, much superior in resolution, contrast and color rendition is achieved over 100% of the effective, even, super-wide field of view, for observation as well as color photomicrography.

1. Objectives

Mechanical tube length of 160mm and parfocal distance of 45mm (This is longer than the 33.6mm of earlier microscopes). **In every case use the CF objectives in combination with the CF eyepieces.**

1) Types of objective

(1) Achromat (CF)

In this type of objective, the correction of chromatic aberrations is based on the lines C (red) and F (blue). Importance being given to the correction at the center of viewfield, the objectives offer the finest definition and highest contrast of image at the center. Even the 40X and 100X objectives fulfill the "Chromatic Aberration Free" correction, which has been considered difficult so far until now for such high magnifying powers. Furthermore, image flatness has been attained to an appreciable extent.

(2) Plan Achromat (CF Plan)

Same as the above type, the objectives accomplish the correction of chromatic aberrations based on the lines C and F.

In addition, owing to sufficient correction of all the image defects up to the periphery

of viewfield, the objectives provide an unsurpassable high resolution and contrast of image over a wider field.

Focusing at the center means simultaneous focusing at the marginal part of viewfield. They are excellent for ultra-wide observation and photomicrography.

(3) Plan Apochromat (CF Plan Apo)

The use of fluorite and special, low color dispersion optical glasses improves the correction of chromatic aberrations over the entire visible region up to the line g (violet) along with the lines C and F.

These highest-grade objectives with their large numerical apertures produce an ideal image over a wide viewfield. With their outstanding definition, superior color reproducibility, and prominent image flatness, they are especially suited for most profound study of minute structures and color photomicrography.

(4) Epi-fluorescence (CF UV-F)

Exclusively designed for episcopic, fluorescence observation, this type objectives use non-fluorescent and non-solarisation materials and a strictly chosen cementing agent, to increase the transmission of UV exciting light (ultra-violet rays). Special weight being attached to the correction at the center of viewfield, and the numerical apertures made extremely large, they ensure bright and sharp fluorescence images using every excitation method. As immersion fluid, the objectives 10X ~ 100X of this type require the use of non-fluorescent glycerine of high purity.

2) Use of the objective

(1) "Oil immersion objectives (Oil)

The objectives discriminated by the engraving "Oil" are to be **immersed in oil between the specimen and front of the objective.**

When using oil immersion objectives of numerical aperture 1.0 or higher, it is recommended, for making full use of its efficiency, to **use a highclass oil-immersion condenser such as of Achromat/aplanat type, applying oil between the glass slide and condenser as well.**

To see if air bubbles are present in the immersion oil, which deteriorate the image quality, pull out the eyepiece from the eyepiece tube to examine the objective exit pupil inside the tube.

To remove air bubbles, revolve the nose-piece slightly to and fro several times, apply additional oil, or replace the oil.

Be careful not to rotate the nosepiece too far as to soil the ends of the other objectives with oil.

To clean off the oil, pass lens tissue or soft cloth moistened with xylene lightly two or three times over the lens. It is essential at this time to avoid touching the lens with the part of tissue or cloth once used.

Any remnants of oil left on the lens deteriorate the image quality.

(2) **Coverglass**

With the objectives engraved "160/0.17", use a coverglass of 0.17mm in thickness (No. 1½). For the objectives whose N.A. is 0.75 or higher, a coverglass of other thickness than 0.17mm will deteriorate the image definition and contrast.

The indication 160/— on the objective means that no matter whether a coverglass is used or not, no decrease of image definition or of contrast will result.

(3) **Objectives with compensation ring**

When a high power, dry objective of large N.A. is adopted in combination with a coverglass of thickness other than 0.17mm, which will cause sharp reduction of image definition and contrast, it is necessary to use an objective incorporating a compensation ring as below:

First, observe with the compensation ring set to 0.17, and then rotating the ring, focus the image with the fine focus knob, until an image of the highest sharpness and contrast is obtained.

(4) **No-coverglass objectives (NCG)**

Objectives with the indication NCG are suited for observing specimens such as smears without coverglass.

(5) **Objectives with aperture diaphragm**

The objective incorporating an iris diaphragm serves to cut off direct light in darkfield microscopy. Stop down the diaphragm nearly to its minimum opening.

2. Eyepieces

To take full advantage of the CF eyepieces, use them in combination with the CF objectives.

The indication "CF" should serve to prevent their use with other type objectives.

1) CFD eyepieces (CFD)

Being of wide field and high eyepoint type, the CFD eyepieces are only used for observation, obtains prominent image flatness. Compared with the CFW eyepieces, they accomplish the good correction of chromatic aberrations at the periphery of the viewfield in combination with the low magnifying power of CF Plan Achromat objectives.

They are equipped with a diopter ring and a rubber eyeguard. An eyepiece CFD 10×M, incorporating a photo mask, is also available, which enables focusing and framing by the use of the observation tube of the Trinocular Eyepiece Tube "T".

2) CFW eyepieces (CFW)

Being of wide field and high eyepoint type, the CFW eyepieces with diopter ring are only used for observation. They are equipped with a rubber eyeguard.

An eyepiece called CFW 10×M, incorporating a photo mask is also available, which enables focusing and framing by the use of the observation tube of the Trinocular Eyepiece Tube "T".

3) CFUW eyepiece (CFUW)

Featuring extra-wide field of view and high eyepoint, this eyepiece with diopter ring is designed exclusively for observation. It enables observation over a field of view twice as large as that of the ordinary type eyepieces in combination with the ultra-wide tube.

An eyepiece called CFUW 10×M, incorporating a photo mask, is also available, which enables focusing and framing by the use of the observation tube of the Ultra Wide Eyepiece Tube "UW".

4) CF PL Projection lenses (CF PL)

Exclusively designed for photomicrography. Do not use them for observation.

Every eyepiece is liable to gather dirt and dust, which not only appear as shadows but also impair image quality and contrast.

Keep the eyepieces clean at all times.

3. Condensers

1) Abbe condenser

N.A. = 1.25. This is used with $4\times \sim 100\times$ objectives. The graduation of this condenser indicates the diameters in mm of the aperture diaphragm opening.

2) Swing-out Achromat condenser

N.A. = 0.9. Dry system.

It is used in combination with objectives from $2\times$ to $100\times$, and provided with a swing-out top lens which is to be swung out when using the $2\times$ or $4\times$ objective. Its adjustable aperture scale is graduated in N.A. ratings.

3) Achromat/aplanat condenser

N.A. = 1.35. Oil system.

The spherical, coma and chromatic aberrations being ideally corrected, this large aperture condenser is used with $20\times \sim 100\times$ objectives. The standard thickness of glass slide should be 1.2mm.

Apply oil between the condenser and glass slide.

It is recommended that this condenser be employed especially in combination with the Plan Achromat objectives. When using the $100\times$ objective for observation in combination

with the CFW $10\times$ eyepiece, it is possible to close the field diaphragm down to 45% of the viewfield.

4) Darkfield condenser (Oil)

N.A. = 1.43 \sim 1.20. Oil system. Used in dark-field microscopy. Apply oil between the condenser and glass slide. (It is recommended to use a thinner glass slide.)

This condenser is used in combination with the objectives $10\times \sim 100\times$ with aperture diaphragm (N.A.: up to 1.1).

5) Darkfield condenser (Dry)

N.A. = 0.95 \sim 0.8. Dry system. Used in dark-field microscopy. Magnifying powers of usable objectives are $10\times \sim 40\times$ (N.A.: up to 0.7).

4. Illumination System (Fig. 15)

The optical system for illumination in the LABOPHOT microscope is constructed to fulfill the Koehler illumination requirements perfectly, and offers a bright, uniform field without any change-over manipulation.

As a standard light source, use the Halogen lamp 6V 20W (PHILIPS 7388).

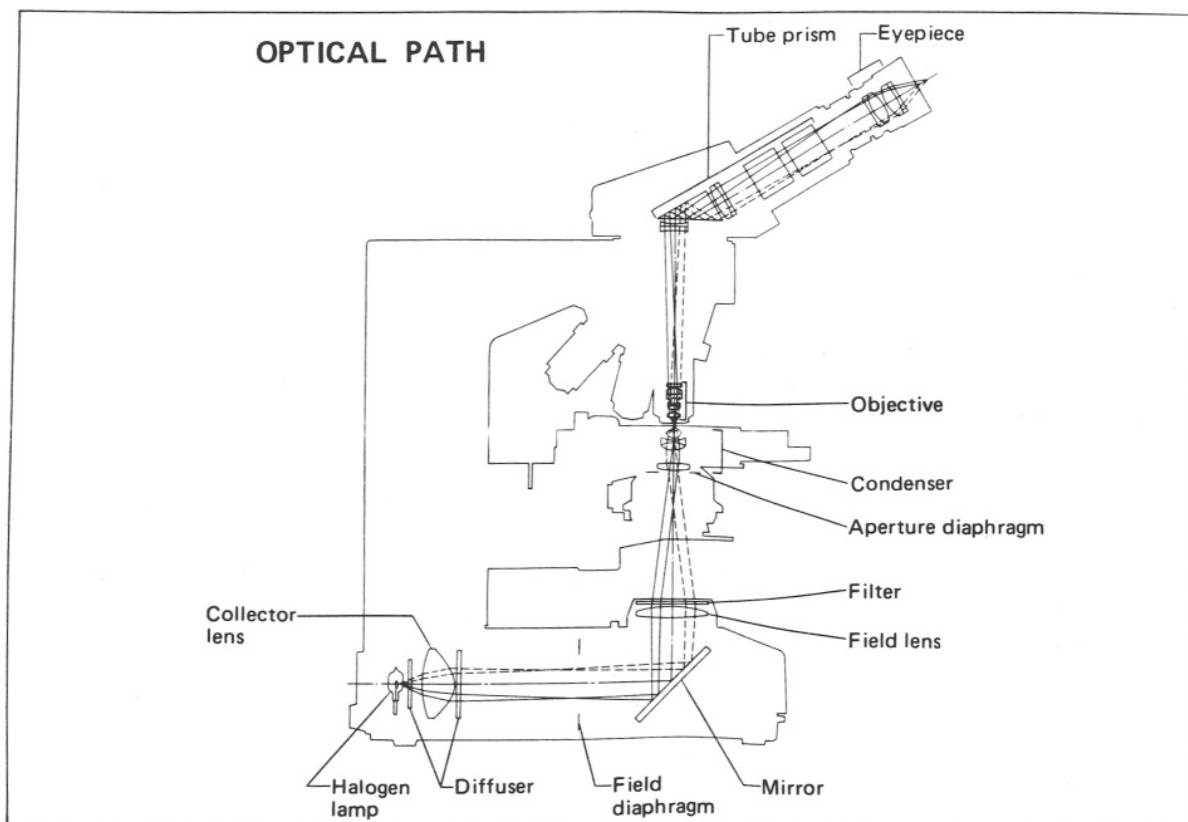

Fig. 15

5. Combinations of Objectives and Eyepieces

Table 2

CF Objectives (160/45) for Biological Microscope		CF Eyepieces																	
		Ordinary viewfield												Ultra-Wide viewfield					
		CFW8x Field number=18				CFW 10x Field number=18				CFW 15x Field number=14				CFUW 10x Field number=26.5					
Type	Magnification	Numerical aperture N.A.	Working distance W.D. mm	Focusing distance f mm	Resolving power μm	Coverglass thickness mm	Total magnification M	Real viewfield ϕ mm	Depth of focus μm	Total magnification M	Real viewfield ϕ mm	Depth of focus μm	Total magnification M	Real viewfield ϕ mm	Depth of focus μm	Total magnification M	Real viewfield ϕ mm	Depth of focus μm	
Plan Apochromat	2x	0.08	5.3	67.9	3.4	—	16x	9.0	155	20x	9.0	132	30x	7.0	102	20x	13.3	132	
	4x	0.16	4.73	36.1	1.7	0.17	32x	4.5	39	40x	4.5	33	60x	3.5	26	40x	6.6	33	
	10x	0.4	0.33	14.2	0.69	0.17	80x	1.8	6.2	100x	1.8	5.3	150x	1.4	4.1	100x	2.7	5.3	
	With compensation ring	20x	0.65	0.5	7.9	0.42	0.17	160x	0.9	2.0	200x	0.9	1.8	300x	0.7	1.4	200x	1.3	1.8
	With compensation ring	40x	0.95	0.1	4.2	0.29	$\frac{0.17}{(0.11 \sim 0.23)}$	320x	0.45	0.8	400x	0.45	0.7	600x	0.35	0.6	400x	0.66	0.7
	Oil	40x	1.0	0.1	3.9	0.28	0.17	320x	0.45	1.1	400x	0.45	1.0	600x	0.35	0.8	400x	0.66	1.0
		60x	0.9	0.1	2.9	0.31	$\frac{0.17}{(0.11 \sim 0.23)}$	480x	0.3	0.7	600x	0.3	0.6	900x	0.23	0.5	600x	0.44	0.6
	Oil	100x	1.35	0.17	1.7	0.2	0.17	800x	0.18	0.4	1000x	0.18	0.4	1500x	0.14	0.3	1000x	0.27	0.4
	Oil	100x	1.35	0.17	1.7	0.2	non	800x	0.18	0.4	1000x	0.18	0.4	1500x	0.14	0.3	1000x	0.27	0.4
	Plan Achromat	1x	0.03	1.8	108.7	9.2	—	8x	18	900	10x	18	782	15x	14	623	—	—	—
2x		0.05	5.8	70.1	5.5	—	16x	9.0	289	20x	9.0	253	30x	7.0	205	20x	13.3	253	
4x		0.1	13.8	40.4	2.8	—	32x	4.5	72	40x	4.5	63	60x	3.5	51	40x	6.6	63	
10x		0.25	7.1	16.7	1.1	—	80x	1.8	11.5	100x	1.8	10.1	150x	1.4	8.2	100x	2.7	10.1	
20x		0.4	1.4	8.4	0.69	0.17	160x	0.9	4.0	200x	0.9	3.5	300x	0.7	2.9	200x	1.3	3.5	
40x		0.65	0.48	4.1	0.42	0.17	320x	0.45	1.3	400x	0.45	1.2	600x	0.35	1.0	400x	0.66	1.2	
NCG		40x	0.65	0.45	4.2	0.42	non	320x	0.45	1.3	400x	0.45	1.2	600x	0.35	1.0	400x	0.66	1.2
Oil		50x	0.85	0.34	3.2	0.32	0.17	400x	0.36	1.2	500x	0.36	1.1	750x	0.28	0.9	500x	0.53	1.1
NCG		60x	0.85	0.35	2.8	0.32	non	480x	0.3	0.7	600x	0.3	0.7	900x	0.23	0.6	600x	0.44	0.7
With compensation ring		60x	0.85	0.43	2.6	0.32	$\frac{0.17}{(0.11 \sim 0.23)}$	480x	0.3	0.7	600x	0.3	0.7	900x	0.23	0.6	600x	0.44	0.7
		100x	0.9	0.1	1.7	0.31	0.17	800x	0.18	0.5	1000x	0.18	0.5	1500x	0.14	0.4	1000x	0.27	0.5
NCG		100x	0.9	0.26	1.6	0.31	non	800x	0.18	0.5	1000x	0.18	0.5	1500x	0.14	0.4	1000x	0.27	0.5
Oil		100x	1.25	0.2	1.8	0.22	0.17	800x	0.18	0.5	1000x	0.18	0.4	1500x	0.14	0.4	1000x	0.27	0.4
Achromat		4x	0.1	20	31.0	2.8	—	32x	4.5	72	40x	4.5	63	60x	3.5	51	Resolving power: $\frac{\lambda}{2 \times \text{N.A.}}$ ($\lambda = 0.55 \mu\text{m}$ standard wavelength) Depth of focus: $\frac{n \times \lambda}{2 \times (\text{N.A.})^2} + \frac{n}{7 \times \text{N.A.} \times M}$ (Resolving power of eye = 2', n: Refractive index of object side)		
	10x	0.25	5.6	16.6	1.1	—	80x	1.8	11.5	100x	1.8	10.1	150x	1.4	8.2				
	20x	0.4	2.23	8.8	0.69	0.17	160x	0.9	4.0	200x	0.9	3.5	300x	0.7	2.9				
	With compensation ring	20x	0.4	2.2	8.8	0.69	$\frac{0.17}{(0.11 \sim 0.23)}$	160x	0.9	4.0	200x	0.9	3.5	300x	0.7	2.9			
		40x	0.65	0.53	4.4	0.42	0.17	320x	0.45	1.3	400x	0.45	1.2	600x	0.35	1.0			
	LWD With compensation ring	40x	0.55	1.3	4.0	0.5	$\frac{1.0}{(0.1 \sim 2.0)}$	320x	0.45	1.7	400x	0.45	1.6	600x	0.35	1.3			
	Oil	100x	1.25	0.14	1.8	0.22	0.17	800x	0.18	0.5	1000x	0.18	0.4	1500x	0.14	0.4			
Epi-illum. fluorescence UVF	With aperture diaphragm	100x	1.25	0.14	1.8	0.22	0.17	800x	0.18	0.5	1000x	0.18	0.4	1500x	0.14	0.4			
		10x	0.5	0.9	14.3	0.55	0.17	80x	1.8	4.7	100x	1.8	4.0	150x	1.4	3.0			
	Glycerin	10x	0.5	0.28	16.2	0.55	0.17	80x	1.8	6.9	100x	1.8	5.8	150x	1.4	4.4			
		20x	0.75	0.66	7.8	0.37	0.17	160x	0.9	1.7	200x	0.9	1.4	300x	0.7	1.1			
	Glycerin	20x	0.8	0.2	8.9	0.34	0.17	160x	0.9	2.3	200x	0.9	2.0	300x	0.7	1.5			
		40x	0.85	0.37	4.2	0.32	0.17	320x	0.45	0.9	400x	0.45	0.8	600x	0.35	0.7			
	Glycerin	40x	1.3	0.1	4.5	0.21	0.17	320x	0.45	0.8	400x	0.45	0.6	600x	0.35	0.5			
	100x	1.3	0.13	1.7	0.21	0.17	800x	0.18	0.4	1000x	0.18	0.4	1500x	0.14	0.3				

V. PHOTOMICROGRAPHY

(The Biological Microscope LABOPHOT is designed mainly for observation.)

1. Combination of CF Objectives and CF PL Projection lens

The combined use of the CF objectives and CF PL Projection lens is essential.

For the same total magnification, select a combination of the highest possible objective power and lowest possible projection lens power to achieve the utmost image definition and contrast.

2. Checking the Illumination

Unevenness in the illumination will show up more conspicuously in photomicrography than in observation. Consequently, before taking a photograph, recheck the correct adjustment of the condenser.

3. Selection of Voltage and Filter

1) When using a daylight type color film

Set the brightness control dial to 5.5 and use the NCB10 filter*.

Adjustment of the image brightness should be made by means of the ND filters.

2) When using a monochrome film

Remove the NCB 10 filter. Contrast filters such as X-1 green are usable.

* The NCB 10 filter is most suitable for a standard film. Depending upon the make of the film different color renditions may result. It is recommended that in addition to the NCB 10 filter a color compensation filter (CC filter), available from the film manufacturer, be used.

4. Shutter Speed

Desirable shutter speeds for least vibration are $1/4 \sim 1/15$ sec.

Adjustment of the image brightness for color photomicrography should be made by means of the ND filters. Some specimens require, on account of their insufficient brightness, longer exposure times, and consequently poor color reproducibility owing to the "Reciprocity Law

Failure" of film may result. So, when taking picture of such specimens, it is recommended to use the Nikon Biological microscope OPTIPHOT.

5. Manipulation of Field and Aperture Diaphragms

In photomicrography, the adjustment of the field diaphragm is important for the purpose of limiting extraneous light which causes flare in the microscope image. Stop down the diaphragm so as to get an illuminated area slightly larger than that of the picture field. By adjusting the aperture diaphragm, a change of depth of focus, contrast and resolution of image is attainable. Select a size suited to the purpose. Generally speaking, the aperture diaphragm, is properly stopped down to 70 ~ 80% of the aperture of the objective being used.

6. With Regard to Condensers

For photomicrography, it is generally recommended to use the Swing-out Achromat condenser. When using 2X objective, however, preferably remove the condenser.

7. Focusing

Focusing is to be accomplished by means of the ocular finder on the photomicrographic attachment, or binocular observation tube with mask eyepiece on the trinocular eyepiece tube.

Table 3. Focusing

Type of eyepiece tube	Focusing with 10× or higher objective	Focusing with 4× or lower objective
"F" tube	Use Ocular finder	Use Ocular finder + Focusing magnifier
"T" or "UW" tube	Use observation tube	Use observation tube or Ocular finder + Focusing magnifier

① Adjust diopter.

● **Binocular of eyepiece tube:**

Use 4X or 10X objective.

Insert the mask eyepiece into either of right or left eyepiece sleeve that is accustomed to usual use. Adjust the diopter ring to bring the double cross line in the view field center into focus. (Fig. 16)

Then focus the specimen image also on the central area of the mask by means of the focus knob of the microscope.

The diopter of another eyepiece is to be adjusted by focusing specimen rotating the diopter ring without using the microscope focus knob.

Rotate the mask eyepiece so as the mask positions as shown in Fig. 19.

● **Ocular finder:**

Adjust the diopter ring so as the double cross line in the view field center can be seen clear and each line separated. (Fig. 17)

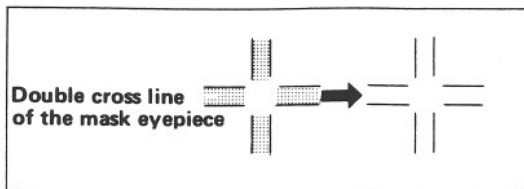

Fig. 16

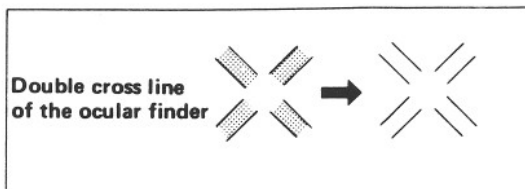

Fig. 17

② Make focusing according to the magnification of objective to be used.

● **Using 40X or higher objective:**

With diopter adjusted eyepiece make the specimen image sharp by rotating the microscope fine focus knob and make sure that both of the double cross line and the specimen image are seen crisply at the same time.

● **Using medium magnification objective 10X, 20X, etc.:**

After focusing the same way as above, bring the specimen image to coincide with

the double cross line so as their relative position is fixed and unchanged under observation by swinging your eye laterally. (Focusing by parallax method.)

● **Using 4X or lower objective:**

Attach the focusing magnifier to the ocular finder. (Fig. 18)

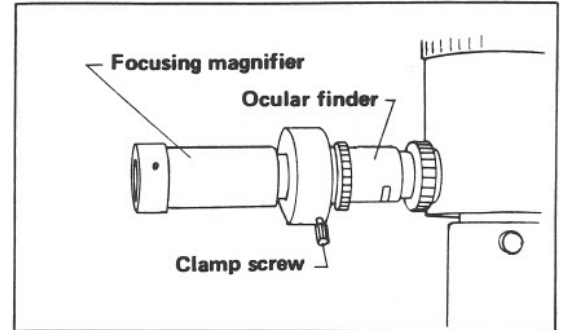

Fig. 18

Viewing through the attached focusing magnifier, move it back and forth until the double cross line is seen clear. Then, focus the double cross line and the specimen image by rotating the fine focus knob as sharp as possible.

8. Picture composing

Compose the picture within the mask in the ocular finder corresponding to the film size in use by driving the microscope stage by lateral and longitudinal movement and rotation. (Fig. 19)

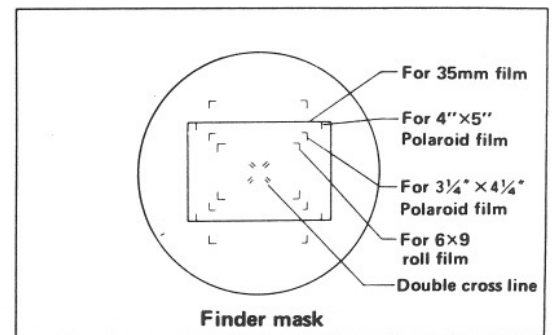

Fig. 19

Masks of the mask eyepiece are applicable to 35mm film picture composing. Select one out of masks suitable to the CF PL Projection lens in use.

Note that, however, framing for picture composing will be more accurate by the ocular finder than the mask eyepiece.

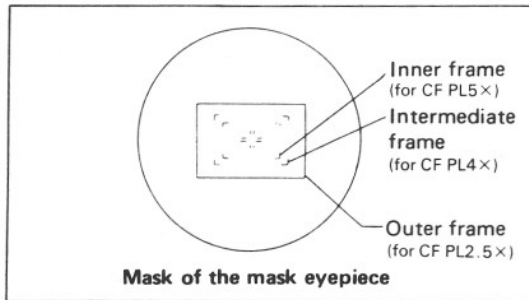

Fig. 20

9. Vibration-free operation

Set the microscope on a vibration-resistant, rigid desk or a bench with a vibration-proof device.

10. Others

- When using the $1\times$ objective, place the diffuser (available on order), and remove the condenser.
- For photomicrography, when focusing with the binocular observation tube, use the CF eyepiece, CF PL Projection lens and CF photo mask eyepiece, with the magnification and other indications engraved in yellow, or in white with a white dot in addition.
- For the use of other photomicrographic attachment refer to the pertinent instruction manuals.

VI. USE OF THE ACCESSORIES

1. Ultra Wide Field Trinocular Eyepiece Tube "UW"

1) Objectives

CF Plan Achromat 2X ~ 100X, CF Plan Apochromat 2X ~ 100X, CF Plan Achromat for phase contrast 10X ~ 100X, CF Plan Achromat for metallurgical 5X ~ 100X, CF Plan Apochromat for metallurgical 50X or CF BD Plan Achromat for bright and darkfield 5X ~ 100X are used.

2) Condenser

Refer to the Table 1 (P. 8).

3) Assembly and microscopy

Assembly and microscopy being almost the same as that of the regular microscopy (P. 6 and P. 8), only the differences will be described below.

(1) Using the centering telescope

For attaching the centering telescope on top of the eyepiece sleeve, it is necessary to use the adapter (Fig. 21), because the telescope which has been originally designed for centering the annular diaphragm in phase contrast microscopy, has a fitting diameter different from that of the CFUW eyepiece.

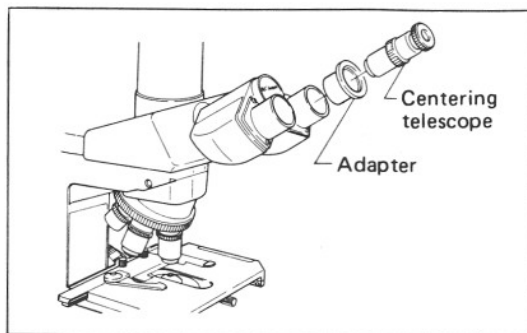

Fig. 21

2. Polarizing Filter Set "PT"

1) Nomenclature (Fig. 22)

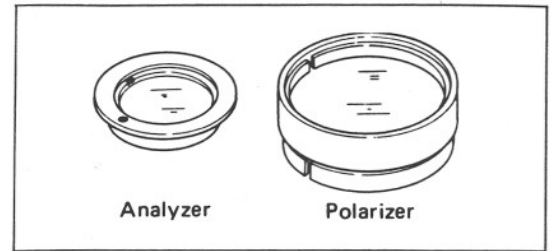

Fig. 22

2) Assembly

(1) Attaching the analyzer

After removing the eyepiece tube, insert the analyzer into the optical path hole in the microscope arm. (Fig. 23)

The white index dot is to be brought into coincidence with the Y-axis (of X-Y coordinates), viewing the arm from above.

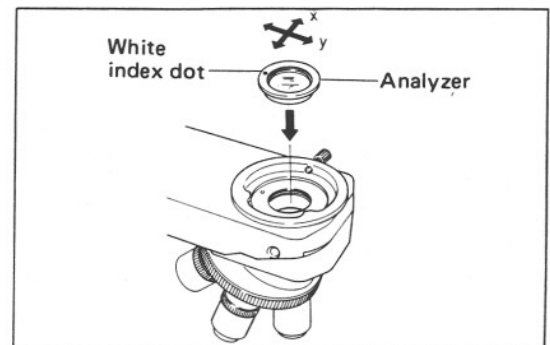

Fig. 23

(2) Condenser

Use the Swing-out condenser.

(3) Attaching the polarizer

As shown in Fig. 24, fit the polarizer to the internal diameter at the bottom of the condenser.

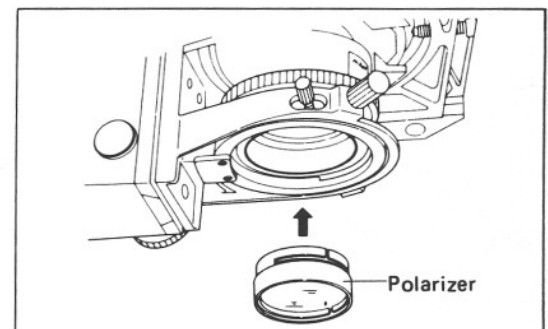

Fig. 24

(4) Objective

Use the ordinary CF objectives.

3) Microscopy

- (1) Turn ON the power switch. Set the brightness control dial to 4.
- (2) Remove the dust cap and place the daylight filter.
- (3) Place the specimen on the stage and focus on specimen with 10× objective.
- (4) Adjust the interpupillary distance and diopter. (Refer to P. 9)
- (5) Swing in the top lens of the swing-out condenser in the optical path. (If using 4× objective swing out the top lens.)
- (6) Center the condenser. (Refer to P. 10)
- (7) Rotate the polarizer until the darkest field of view is obtained.
- (8) Set the brightness control dial to 5 ~ 6.
- (9) Change over the objective to be used and sharpen the focus on the specimen.
- (10) Adjust the aperture diaphragm and field diaphragm. (Refer to P. 10 and 11)

(NOTE)

The following accessories can not be used in combination with LABOPHOT (Y-R stand) Microscope.

- Teaching Head and Multi-teaching Head (Only when they are combined with Ultra Wide Eyepiece Tube "UW")
- Epi-illuminator "M"

VII. TROUBLE SHOOTING TABLE

Although nowhere the user can find any disorder or derangement in the instrument, if he encounters some difficulty or dissatisfaction, recheck the use, referring to the table below:

1. Optical

Failures	Causes	Actions
Darkness at the periphery or uneven brightness of view-field (No appearance of viewfield)	<ul style="list-style-type: none"> ● Optical path in trinocular tube not fully changed-over ● Revolving nosepiece not in click-stop position (Objective not centered in optical path) ● Condenser not centered ● Field diaphragm too much closed ● Dirt or dust on the lens (Condenser, objective, eyepiece, slide) ● Improper use of condenser 	<ul style="list-style-type: none"> → Changing-over to the limit (Refer to P. 9) → Revolve it to click-stop position → Centering by using field diaphragm (Refer to P. 10) → Open it properly → Cleaning → Correct use (Refer to P. 10)
Dirt or dust in the viewfield	<ul style="list-style-type: none"> ● Dirt or dust on the lens (Condenser, objective, eyepiece, field lens) ● Dirt or dust on the slide ● Too low position of condenser 	<ul style="list-style-type: none"> → Cleaning → Cleaning → Correct positioning (Refer to P. 10)
No good image obtained (low resolution or contrast)	<ul style="list-style-type: none"> ● No coverglass attached to slide or NCG objective used with coverglass ● Too thick or thin coverglass ● Immersion oil soils the top of dry system objective (especially 40X) ● Dirt or dust on the lens (Condenser, objective, eyepiece, slide) ● No immersion oil used on immersion system objective ● Air bubbles in immersion oil ● Not specified immersion oil used ● Condenser aperture and field diaphragm too much opened ● Dirt or dust on the entrance lens ● Compensation ring in objective not adjusted ● Objective aperture (which provided) too much closed 	<ul style="list-style-type: none"> → Correct use (Refer to P. 13) → Use specified thickness (0.17mm) coverglass (Refer to P. 13) → Cleaning → Cleaning → Use immersion oil (Refer to P. 12) → Remove bubbles → Use Nikon immersion oil → Close properly (Refer to P.10, 11) → Cleaning → Adjustment (Refer to P. 13) → Open properly
Image quality deteriorated	<ul style="list-style-type: none"> ● Condenser aperture too much closed ● Too low position of condenser 	<ul style="list-style-type: none"> → Open properly (Refer to P. 10) → Bring it up to coincidence with field diaphragm image (Refer to P. 10)
Oneside dimness of image	<ul style="list-style-type: none"> ● Revolving nosepiece not in click-stop position 	<ul style="list-style-type: none"> → Revolve it to click-stop position

Failures	Causes	Actions
Image moves while being focused	<ul style="list-style-type: none"> ● Specimen rises from stage surface → ● Revolving nosepiece not in click-stop position → ● Condenser not correctly centered → ● Optical path in trinocular tube not fully changed-over → 	<ul style="list-style-type: none"> → Place it stable → Revolve it to click-stop position → Correct centering (Refer to P.10) → Changing-over to the limit (Refer to P. 9)
Image tinged yellow	<ul style="list-style-type: none"> ● Daylight filter not used → 	<ul style="list-style-type: none"> → Use daylight filter

2. Manipulation

Failures	Causes	Actions
No focused image obtained with high power objectives	<ul style="list-style-type: none"> ● Upside down of slide → ● Too thick coverglass → 	<ul style="list-style-type: none"> → Turn over the slide → Use specified thickness (0.17mm) coverglass (Refer to P. 13)
High power objective touches the slide, when changed-over from low power	<ul style="list-style-type: none"> ● Upside down of slide → ● Too thick coverglass → ● Eyepiece diopter not adjusted (Especially when changing-over low power objective 1× or 2×) → 	<ul style="list-style-type: none"> → Turn over the slide → Use specified thickness (0.17mm) coverglass (Refer to P. 13) → Diopter adjustment (Refer to P. 9)
Insufficient parfocality of objective (when changed-over)	<ul style="list-style-type: none"> ● Eyepiece diopter not adjusted → 	<ul style="list-style-type: none"> → Diopter adjustment (Refer to P. 9)
Movement of image not smooth by moving the slide	<ul style="list-style-type: none"> ● Slide holder not tightly fixed → 	<ul style="list-style-type: none"> → Fix it tightly
Travel of stage limited to one half length of slide	<ul style="list-style-type: none"> ● Improper attaching of slide → 	<ul style="list-style-type: none"> → Shift the attaching position holder
No fusion of binocular images	<ul style="list-style-type: none"> ● Interpupillary distance not adjusted → 	<ul style="list-style-type: none"> → Adjustment (Refer to P. 9)
Fatigue of observing eyes	<ul style="list-style-type: none"> ● Incorrect diopter adjustment → ● Inadequate brightness of illumination → 	<ul style="list-style-type: none"> → Correct adjustment (Refer to P.9) → Change power voltage

3. Electrical

Failures	Causes →	Actions
Lamp does not light even though switched ON	<ul style="list-style-type: none"> ● No electricity obtained → ● No lamp bulb attached → ● Lamp bulb blown → ● Fuse blown → 	<ul style="list-style-type: none"> Connect the cord to socket Attaching Replacement Replacement
Unstable brightness of illumination	<ul style="list-style-type: none"> ● Input voltage not adjusted to house current voltage (for European districts only) → ● House current voltage fluctuates too much → 	<ul style="list-style-type: none"> Turn the change-over switch on the microscope bottom Use transformer or the like (for adequate voltage)
Lamp bulb promptly blown	<ul style="list-style-type: none"> ● Not specified lamp bulb used → ● Too high voltage of house current → 	<ul style="list-style-type: none"> Use 6V 20W specified lamp bulb: (Halogen bulb: PHILIPS 7388) Use transformer for adjustment
Insufficient brightness of illumination	<ul style="list-style-type: none"> ● Condenser not centered → ● Condenser aperture too much closed → ● Too low position of condenser → ● Not specified lamp bulb used → ● Dirt or dust on lens (condenser, objective, eyepiece, field lens, filter) → ● Too low voltage → 	<ul style="list-style-type: none"> Centering (Refer to P. 10) Open it properly (Refer to P. 10) Correct positioning (Refer to P. 10) Use 6V 20W specified Halogen bulb (PHILIPS 7388) Cleaning Raise the voltage
Fuse blown	<ul style="list-style-type: none"> ● Not specified fuse used → 	<ul style="list-style-type: none"> Use 1A (250V) or 0.5A (250V)
Flickering or unstable brightness of lamp bulb	<ul style="list-style-type: none"> ● Lamp bulb going to be blown → ● Lamp bulb not inserted to the limit → ● Fuse holder not firmly fastened → ● Irregular change of house current voltage → ● Lamp bulb insufficiently inserted into the socket → 	<ul style="list-style-type: none"> Replacement Secure connection Firm fastening Use stabilizer Positive connection

4. Photomicrography

Failures	Causes →	Actions
No sharp picture obtained	<ul style="list-style-type: none"> ● Improper focusing → 	<ul style="list-style-type: none"> ● Viewing into the finder and turning diopter ring, bring double crosshair into focus. Moving the eye laterally, rotate fine focus knob, until no parallax separation appears between the image and double crosshair. ● At lower magnifications use focusing telescope in addition.

Failures	Causes →	Actions
<p>No sharp picture obtained</p>	<ul style="list-style-type: none"> ● Out of focus → (Especially with high power objective and long-exposure) ● Momentary vibration → ● Incorrect thickness of coverglass → (Especially, when using large N.A. and high power objective) ● Using dry objectives for smear preparations → 	<ul style="list-style-type: none"> ● For preventing external vibration, use vibration-proof table or rigid desk. ● Select a place free from vibrations, such as caused by traffic, passers-by or motors etc. ● Using ND filters or others, elongate exposure time (for color film, to 1/4 ~ 1/15 sec.) ● Lower the voltage, and elongate exposure time (for black-and-white film). Note, however, for color film, that lowering of color temperature and change of spectral characteristics will be unavoidable. ● Use a standard coverglass of 0.17mm in thickness. (No. 1 ½) ● Use objective with coverglass thickness compensation ring. ● Use no-coverglass type objective. ● If other objectives are to be used, place a coverglass on the specimen.
<p>Fogging of image</p>	<ul style="list-style-type: none"> ● Grease, dust or dirt on optical surfaces → 	<ul style="list-style-type: none"> ● Clean the front of objective thoroughly, top surface of projection lens, specimen, photographic lens, condenser lens, field lens, etc.
<p>Illuminated image not uniformly</p>	<ul style="list-style-type: none"> ● Condenser not centered → (This shows up more conspicuously in photography than in observation) 	<ul style="list-style-type: none"> ● Centering (Refer to P. 10)
<p>Insufficient image contrast</p>	<ul style="list-style-type: none"> ● Aperture diaphragm opened too large → ● Incorrect use of filter → ● Inadequate use of field diaphragm → 	<ul style="list-style-type: none"> ● Generally, good results will be achieved with aperture stopped down to 70 ~ 80% of N.A. of the objective being used. (Refer to P. 10) ● In metallurgical, interference, polarizing or phase contrast microscopy, use of a green filter or monochromatic interference filter (e.g. peak wavelength = 546nm, half-value range = 30 nm) will increase contrast. ● When contrast is to be increased for a part stained with a particular color, use a filter whose color is complementary to the stain color (for black-and-white film). ● Stop down field diaphragm to a diameter slightly larger than the diagonal of picture frame. (Refer to P. 16)

Failures	Causes →	Actions
Insufficient image contrast	<ul style="list-style-type: none"> ● Low contrast in specimen 	<ul style="list-style-type: none"> ● To increase contrast optically, select phase contrast, darkfield, or differential interference methods. ● Specimens should be stained a rather dark color, if possible. ● In color photography, depending upon the specimen, red-blue separation staining (Mallory or Azan methods etc.) is preferable to red-violet combination staining (H-E staining). ● In black-and-white photography, for low contrast specimens a film of finer grain and higher contrast is more suited (such as minicopy film). ● For general specimens a film of wider latitude and finer grain is preferable.
Deficient resolving power of microscope	<ul style="list-style-type: none"> ● Insufficient N.A. of objective ● Excessive magnification 	<ul style="list-style-type: none"> ● Use a large N.A. objective. ● For the same magnification, increase power of objective rather than that of eyepiece to attain higher resolution and sharpness, even though depth of field is reduced. ● 500 ~ 1000 times N.A. are magnification limits for resolving power.
Ghosts or flare appears	<ul style="list-style-type: none"> ● Extraneous light entering the ocular finder ● Stray light entering 	<ul style="list-style-type: none"> ● Darken the surroundings or place the cap on the ocular finder. ● Take care not to expose microscope and specimen to direct sunlight and other intense lights.
Poor photograph obtained	<ul style="list-style-type: none"> ● Inadequate use of filter ● Film of another make or emulsion NO. ● Wrong power source voltage used ● Incorrect exposure time ● Influenced by film development 	<ul style="list-style-type: none"> ● Select best filter combination. ● Note that, when using a daylight film, remarkably different spectral sensitivities will result depending upon the type, make, etc. ● Even though of same make, according to emulsion number, different color rendition will be obtained. ● Take picture in every case at the specified voltage. (Refer to P. 16) ● By inadequate exposure time, color rendition will not be true on account of "reciprocity law failure" Then, with the help of exposure time indicator, adjust exposure time according to characteristics of film by means of ND filters, or compensate for such failure by means of CC filters. (Refer to Kodak Data) ● Especially, for making color prints, it is recommended to contact the development laboratory.

ELECTRIC SPECIFICATIONS

Power source	100V 120V 50/60 Hz 220/240V
Halogen lamp	6V 20W (PHILIPS 7388)
Fuse	100V } 1A (250V) 120V } 220/240V 0.5A (250V)

Nikon reserves the right to make such alterations in design as may be considered necessary in the light of experience. For this reason, particulars and illustrations in this handbook may not conform in every detail to models in current production.

NIKON CORPORATION

FUJI BUILDING 2-3, MARUNOUCHI 3-CHOME, CHIYODA-KU, TOKYO 100, JAPAN
PHONE: 03-214-5311 TELEX: J22601 NIKON, FAX: 03-214-1780

Printed in Japan

6(89.2.B)H·E-6