

INSTRUCTIONS

MODEL **BHTU**
BIOLOGICAL MICROSCOPE

scanned on Nov. 6, 2009 by J.G.McHone
for personal use only, not for sale

WARNING

*This instruction manual is for use of your instrument.
Before putting it into operation, we recommend you
read this manual carefully in order to familiarize your-
self fully with its use so that you may obtain opti-
mum performance.*

OLYMPUS®



A X 5 7 5 1

This instruction manual has been written for the use of the Olympus Biological Microscope Model BHTU. It is recommended that you read the manual carefully in order to familiarize yourself fully with the use of the microscope, so that you will obtain optimum performance.

IMPORTANT

Observe the following points:

■ Operation

1. Always handle the microscope with the care it deserves, and **avoid abrupt motions**.
2. Avoid the use and maintenance of the microscope in **direct sunlight, high temperature and humidity, dust and vibration**.
3. Only use the tension adjustment ring for altering the tension of the coarse adjustment knobs. (Do not twist the two coarse adjustment knobs in opposite directions simultaneously, as this will cause damage.)
4. Make sure that the voltage selector switch on the bottom base of the microscope stand is set to conform with the local mains voltage.
5. Ground the microscope in case there is no ground terminal in your mains line.

■ Maintenance

1. Lenses must always be kept clean. Carefully wipe off oil or fingerprints deposited on the lens surfaces with gauze moistened with a **small** amount of xylene, alcohol or ether.
2. Do not use organic solutions to wipe the surfaces of various components. Plastic parts, especially, should be cleaned with neutral detergent.
3. Never disassemble the microscope for repair. Only authorized Olympus service personnel should make repairs.
4. The microscope should be covered with the vinyl dust cover provided and stored in a place free from humidity and fungi.

CONTENTS

I.	STANDARD CONFIGURATIONS	2
II.	NOMENCLATURE	3
III.	ASSEMBLY	4
IV.	IDENTIFICATION AND FUNCTION OF VARIOUS COMPONENTS	6
V.	OPERATION	9
	A. Switching ON the Light Source	9
	Voltage Adjustment and Light Intensity	
	LP (Light Intensity Presetting) Switch	
	B. Placement of a Specimen Slide	10
	White Cover for Condenser	
	Cover Glass	
	Specimen Slide	
	Stage	
	C. Observation Tube	12
	1. Interpupillary Distance Adjustment	
	2. Diopter Adjustment	
	3. Light Path Selector	
	D. Condenser Adjustment	13
	1. Condenser Centration	
	Filed Iris Diaphragm	
	Aperture Iris Diaphragm	
	E. Focusing Adjustment	14
	1. Tension of Coarse Adjustment Knobs and Fine Adjustment	
	Use of Rubber Cap for Fine Adjustment Knob	
	2. Pre-Focusing Lever	
	F. Use of Immersion Objectives	15
	G. Photomicrography	15
VI.	OPTICAL DATA	17
VII.	TROUBLESHOOTING GUIDE	18

I. STANDARD CONFIGURATIONS

Component		Model			
		BHTU-111	BHTU-112	BHTU-312	
Microscope stand with quintuple revolving nosepiece		BHTU-F	1	1	1
Observation tubes	Binocular tube	BH2-BI30	1	1	0
	Trinocular tube	BH2-TR30	0	0	1
Square mechanical stage with right-hand low drive coaxial controls and specimen holder		BH2-SVR2	1	1	1
Swing-out condenser		BH2-SC	1	1	1
Halogen lamp holder		LS-20H	1	1	1
Halogen bulbs		6V20WHAL	2	2	2
Objectives	D Ach. 4X, D Ach. 10X, D Ach. 40X, D Ach. 100X (oil)		1 each	0	0
	D Plan 4X, D Plan 10X, D Plan 40X D Plan 100X (oil)		0	1 each	1 each
Eyepieces, paired		WK10X	1	1	1
Photo eyepiece		NFK3.3X	0	0	1
Filter		KB-4	1	1	1
Immersion oil, bottled			1	1	1
Vinyl dust cover			1	1	1

II. NOMENCLATURE

The Model BHTU consists of various components and interchangeable accessories as shown in the photo below. A wide variety of combinations, standard or optional, is available according to your requirements.

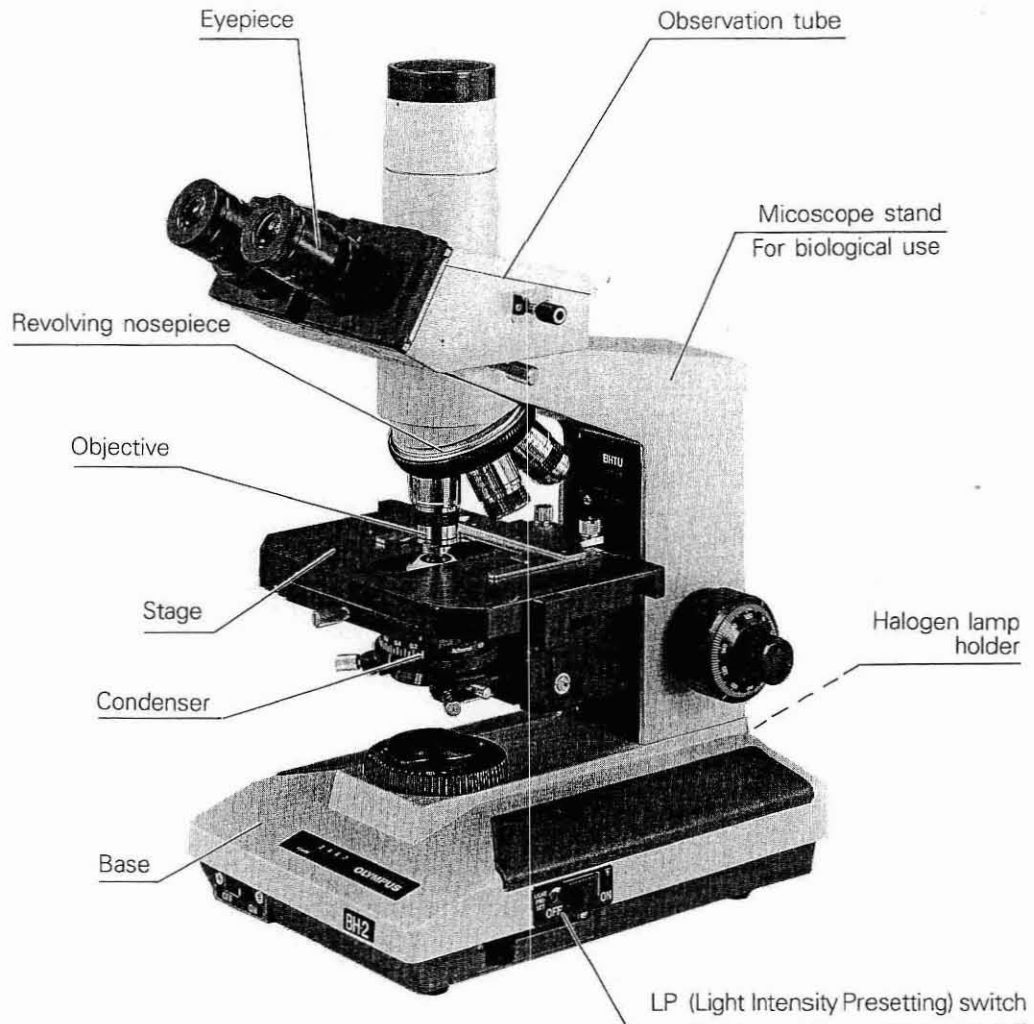

III. ASSEMBLY

This picture illustrates the sequential procedure of assembly. The numbers indicate the order of assembly of various components. Remove dust caps before mounting components. Take care to keep all glass surfaces clean, and avoid scratching the glass surface.

NOTE: For numbers ③ and ⑦ please refer to explanations in detail on the next page.

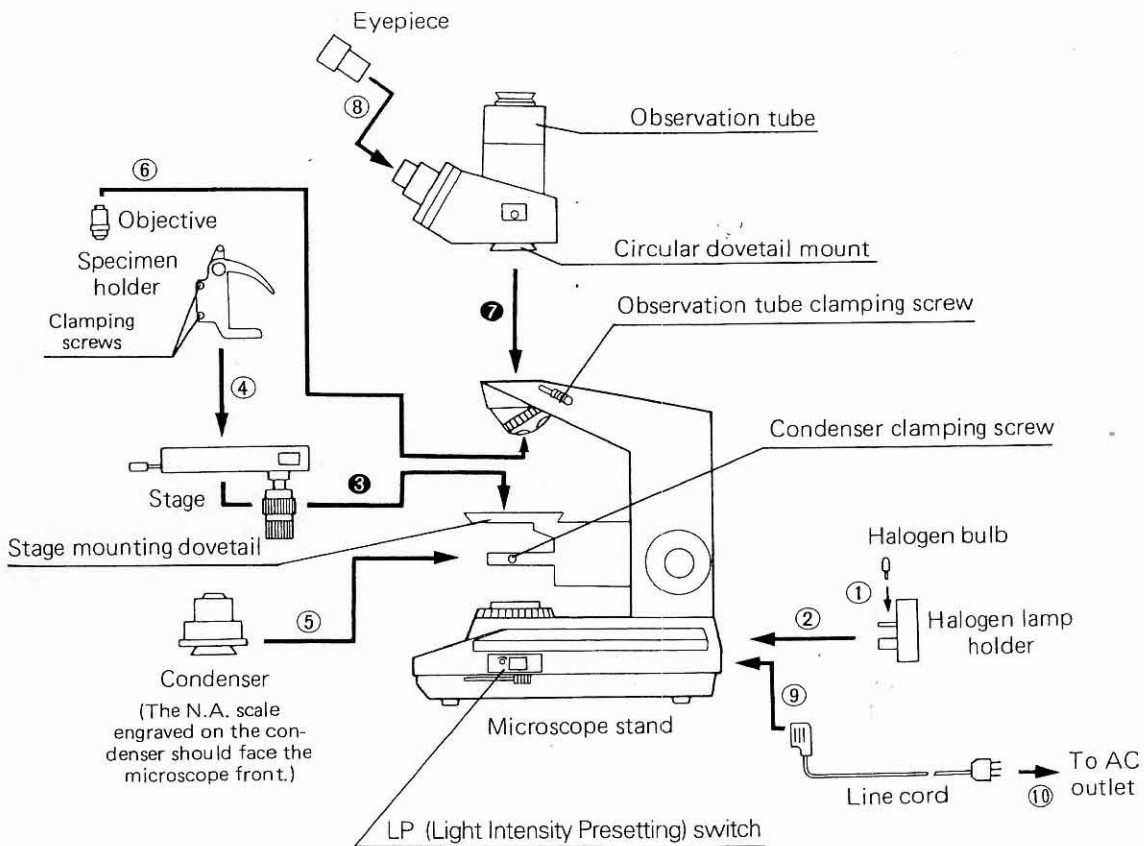

■ Explanations in detail

③ Mounting the stage

- 1) Loosen the stage clamping screw ① by rotating counterclockwise. (Fig. 1)
- 2) Insert the stage into the mounting dovetail of the microscope stand slowly and lock with clamping screw.

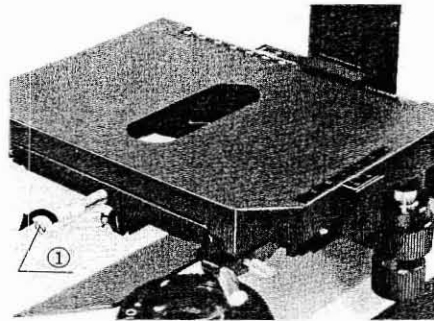

Fig. 1

⑦ Mounting the observation tube

- 1) Loosen the clamping knob ① fully. (Fig.2) Pull spring-loaded clamping knob ①. This will cause the locating pin ② to withdraw. If the pin does not, loosen the screw further until the pin withdraws.
- 2) With clamping knob ① pulled out, insert the circular dovetail of the observation tube into the ring dovetail.
- 3) Tighten the clamping knob.

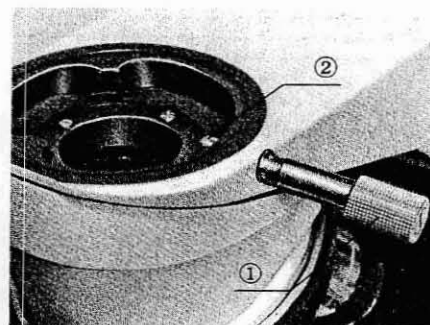
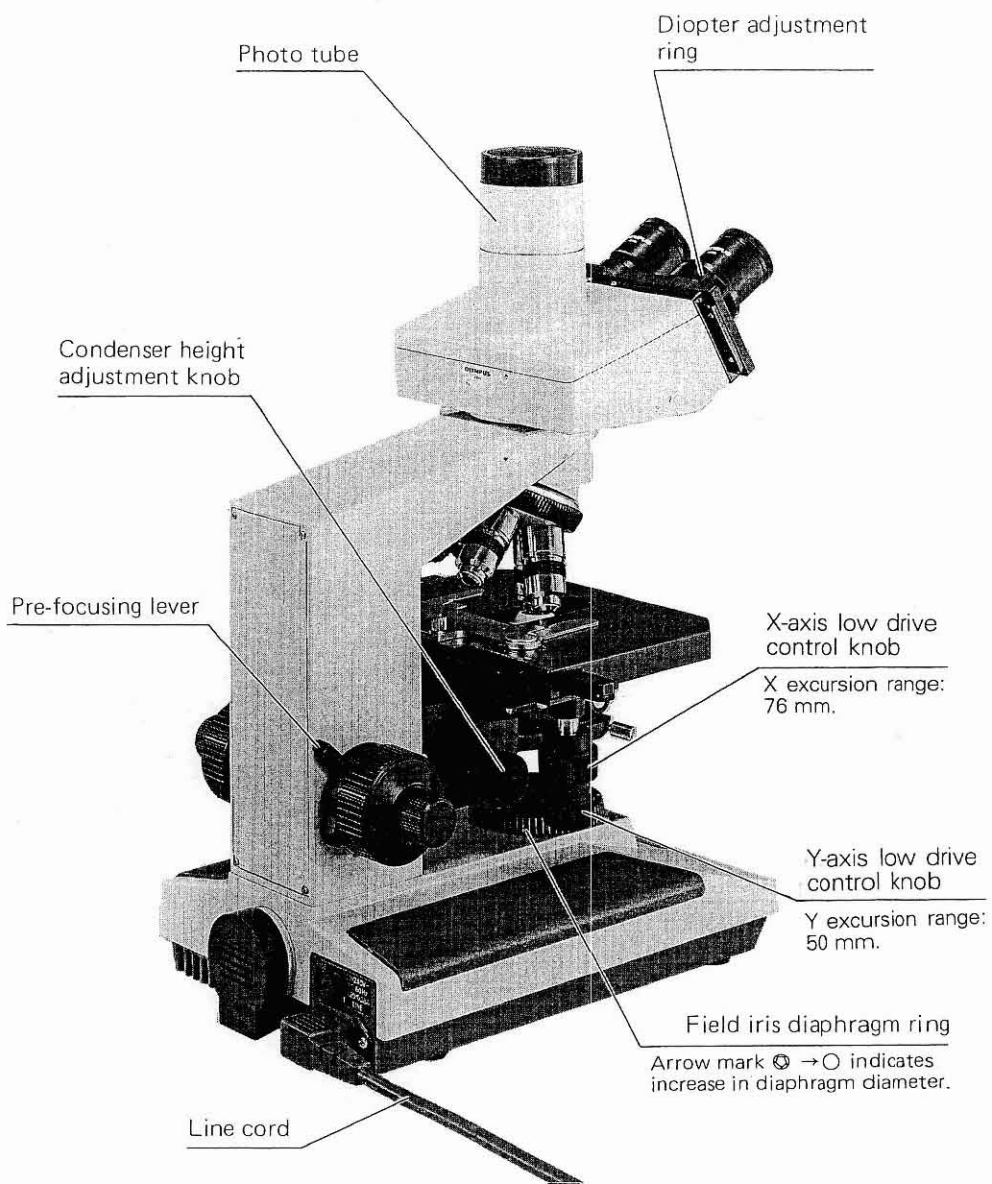

Fig. 2



Summary of Putting the Microscope into Operation

MODEL BHTU

- A. Match the voltage selector switch to local mains voltage (page 9).
- B. Switch on the light source (page 9).
- C. Place a specimen slide on the mechanical stage.
- D. Coarse focus with the 10X objective.
- E. Make interpupillary distance and diopter adjustments (page 12).
- F. Adjust the condenser position (page 13).
- G. Swing in the desired objective.
- H. Adjust light intensity.
- I. Fine focus.
- J. Adjust aperture iris diaphragm and field iris diaphragm (page 13).

Adjustment of Illumination System for Various Objective Powers

Objective magnification	Condenser			
	Achromatic-aplanatic condenser BH2-AAC	Abbe condenser BH2-CD	Swing-out condenser BH2-SC	Low power condenser BH2-UL-C
1X				Compatible
2X				
4X				
10X	Compatible	Compatible	Swing in top lens	
20X				
40X				
60X				
100X			*	

*N.A. is somewhat low, but still compatible with a 100X objective.

(Take a copy of this page and put it on the wall near the microscope for use as a reminder of microscopic procedure.)

OLYMPUS®

V. OPERATION

A. Switching on the Light Source

- 1) Ascertain that the voltage selector switch ① is set to conform with the local mains voltage. (Fig. 3)
If the switch is not correctly set, adjust it by means of the Allen wrench provided, or a screw-driver.
- 2) Place the sliding voltage control lever on the right side of the microscope base to a position closest to you (low voltage position). Switch on the light source (main switch ②). (Fig. 3)

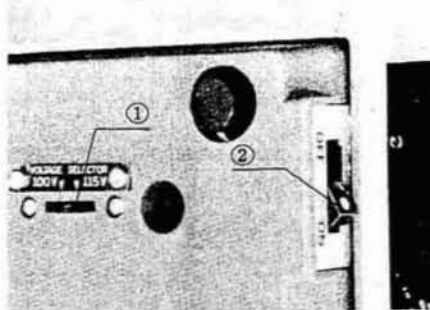

Fig. 3

Voltage Adjustment and Light Intensity

As you push the control lever ① in the direction of the ARROW, the voltage increases, and the LED readout ② will display the lamp voltage. (Fig. 4)



Fig. 4

LP (Light Intensity Presetting) Switch

Apart from the light intensity set by voltage adjustment control lever, the LP switch can set the light intensity as required.

Presetting the light intensity (Fig. 5)

- 1) Switch ON the LP switch ①.
 - 2) Insert a slotted screwdriver into the LP adjustment screw ②. Turning it clockwise will increase the light intensity. Turn it until required intensity is obtained.
- ★ The light intensity will not change even if the voltage adjustment lever ③ with the LP switch ON. To change the light intensity by using the voltage adjustment lever, switch the LP switch OFF. To recall the light intensity preset, push the LP switch to ON.



Fig. 5

A Hint on Convenient Application of the LP Switch

For instance, when you want to use two kinds of objective lens alternately, set one objective by using the voltage adjustment lever, then set another objective lens by using the LP switch. This allows the light intensity to recall the intensity initially preset by switching the LP switch ON and OFF.

This also allows the light intensity setting for photomicrography.

B. Placement of a Specimen Slide

- 1) Rotate the coarse adjustment knobs ① in the direction of the ARROW to rack down the stage so that a specimen slide can be placed on the stage. (Fig. 6)

NOTE: The rotation of the coarse and fine adjustment knobs in the direction of the ARROW will rack down the stage.

- 2) Opening the spring-loaded finger of the specimen holder with one hand, place a specimen slide inside the holder with the other hand. When the slide comes in contact with the back of the specimen holder, slowly return the spring-loaded finger.

WARNING: If the spring-loaded finger is returned too quickly, it may cause damage to the specimen slide.

- 3) For use of the specimen holder B2-HL2
A specimen slide can be easily slipped into the specimen holder by single hand operation. (Fig. 7)

White Cover for Condenser

The white cover for condenser ① should be covered over the condenser. (Fig. 8)

- When setting stain specimens under the specimen holder, the white cover for condenser comes into field of view as a background. This allows easy distinction what you are observing between its background.

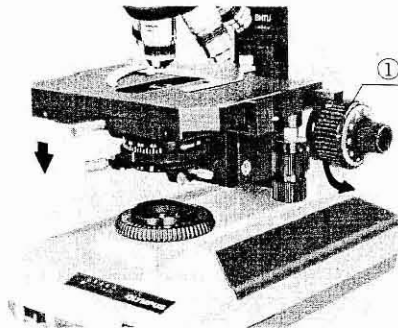

Fig. 6

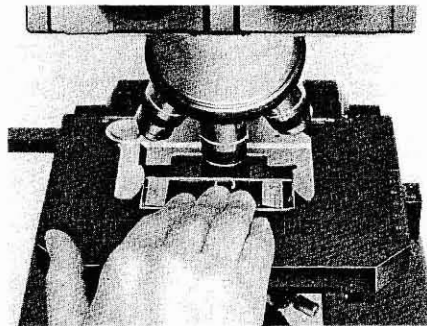

Fig. 7

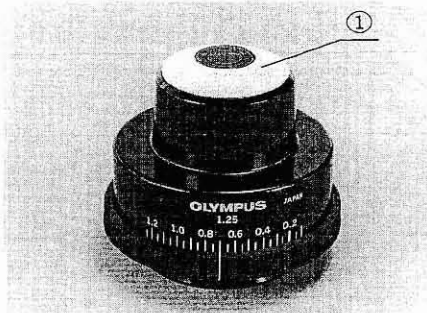

Fig. 8

Cover Glass

- An Olympus objective engraved "160/0.17" requires a cover glass of 0.17mm thickness. If the numerical aperture of the objective is 0.7 or higher (except immersion objectives) and no correction collar is provided, the resolving power deteriorates greatly, if cover glass thickness deviates from the above listed value.

NOTE: In some countries a 0.17 mm thick cover glass corresponds to a #1½ cover glass.

- A cover glass (0.4 mm thick) for blood counting, etc. can be used with Olympus objectives except D Plan 40X, S Plan Apo 40X and S Plan 100X.

Specimen Slide

- Specimen slides 0.8 mm to 1.5 mm thick are recommended for Olympus objectives.
- Specimen slides 0.8 mm to 1.2 mm thick are recommended for the darkfield condenser and the differential interference contrast condenser.

3) Bring the portion of the specimen to be observed into the light path by means of the low drive stage control knobs. (Fig. 9)

★ Tighten the stage clamping screw ① .

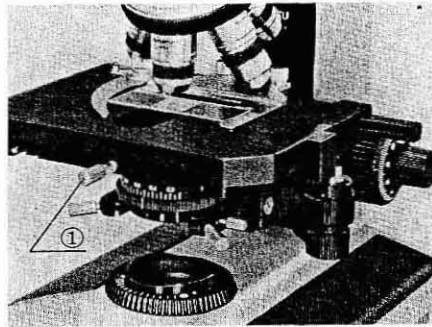

Fig. 9

Stage

- The specimen holder can accommodate two standard specimen slides simultaneously.
- The specimen holder is removable to obtain a large unobstructed stage surface to hold specimens up to 55 mm x 85 mm.
- To rotate the stage loosen the stage clamping screw ① and holding this screw, rotate the stage into the desired direction. (Fig. 10)

◎ Stage clips for use with immersion objectives. (Fig. 11)

A pair of stage clips is optionally available to hold the specimen on the stage, eliminating specimen drag or buckling due to immersion oil between slide and stage surface. The clips can be inserted into the holes ① provided on the specimen holder.

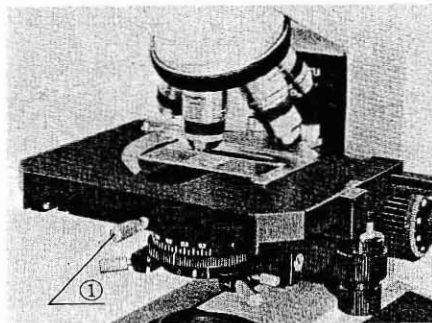

Fig. 10

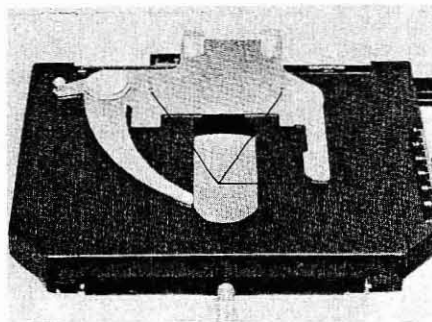

Fig. 11

C. Observation Tube

1. Interpupillary Distance Adjustment

- 1) Click the 10X objective into position.
- 2) Looking through the eyepieces with both eyes, adjust the interpupillary distance of the binocular tube by adjusting the knurled dovetail slides ① of the right and left eyepiece tubes with both hands until perfect binocular vision is obtained. (Fig. 12)

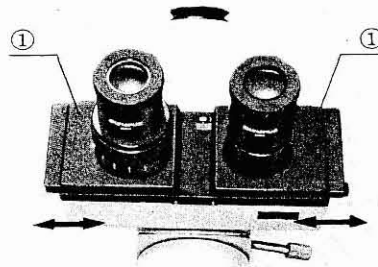

Fig. 12

2. Diopter Adjustment

- 1) Looking at the image through the right eyepiece with your right eye, focus on the specimen with the fine adjustment knobs.
- 2) Next, looking at the image through the left eyepiece with your left eye, rotate the diopter adjustment ring ① to focus on the specimen without using the coarse and fine adjustment knobs. (Fig. 13)

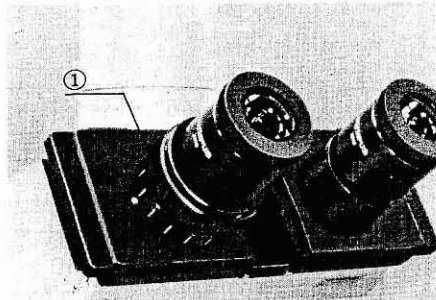

Fig. 13

3. Light Path Selection

- 1) The trinocular tube is provided with a light path selector lever ① to direct the light to the observation tube and/or to the photo tube in 3 positions. (Fig. 14)

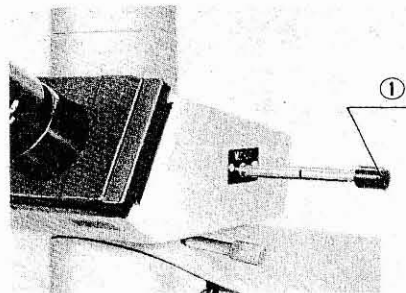

Fig. 14

Indicator Plate

	Lever Position		
	Pushed in all the way (V)	Pulled out halfway (C. V.)	Pulled out all the way (C)
Amount of light	100% into binocular tube	20% into binocular tube 80% into photo tube	100% into photo tube
Application	① Observation ② Dark specimens	① Observation of excessively bright specimens ② Photomicrography (focusing through the binocular tube)	Photomicrography of dark specimens

An indicator plate is provided at the knob port to summarize the usage of the above table; it can be consulted before operating the knob.

V: Viewer (white letters)

CV: Camera & viewer (yellow-green letters)

C: Camera (red letters)

The colors of the letters correspond with the color bands on the knob shaft.

D. Condenser Adjustment

1. Condenser Centration

- 1) Stop down the field iris diaphragm with knurled ring ① by rotating in the direction of the arrow. (Fig. 14)
- 2) Use the condenser height adjustment knob ② to move the condenser up and down until an image of the field diaphragm can be seen clearly in the eyepieces. The rotation of the knob in the direction of the arrow lowers the condenser.

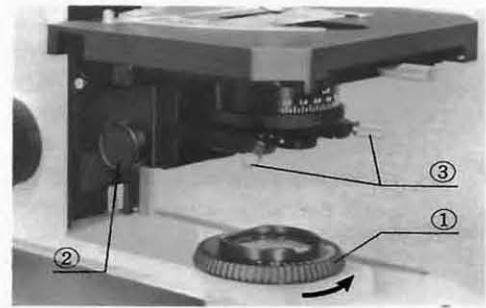

Fig. 14

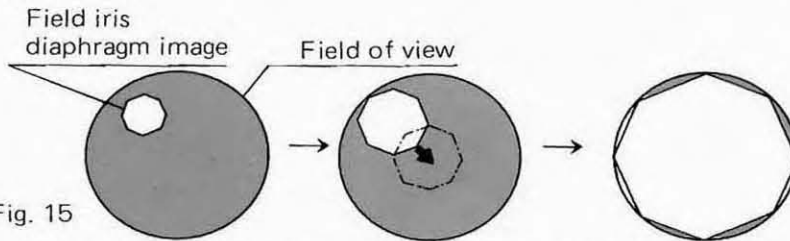

Fig. 15

- 3) Bring the field iris diaphragm image into the center of the field of view with the two condenser centering knobs ③. (Fig. 14)
- 4) Widen the diameter of the iris diaphragm progressively. If the polygonal image of the iris diaphragm becomes inscribed in the field it means that the field diaphragm is centered. (Fig. 15)

Field Iris Diaphragm

- The field iris diaphragm controls the diameter of the ray bundle impinging on the specimen surface and therefore, by stopping down the field diaphragm until it is slightly larger than the field of view, it can reduce stray light, which in turn increases image definition and contrast.

Aperture Iris Diaphragm

- In order to achieve optimum objective performance, the opening of the aperture iris diaphragm should be matched to the numerical aperture of the objective in use. It is often preferable, however, to stop down the aperture diaphragm slightly more than indicated by the objective N.A. This will result in better image contrast, increased depth of focus and a flatter field.
- After completing focus adjustment, remove one of the eyepieces from the observation tube and look into the empty eyepiece tube. As you stop down the aperture iris diaphragm, the image of the iris diaphragm can be seen in the objective pupil. Adjust the opening of the diaphragm to match the N.A. of the objective in use. If the specimen is low in contrast, it is recommended to stop down to 70% ~ 80% of the objective N.A. (Fig. 16)

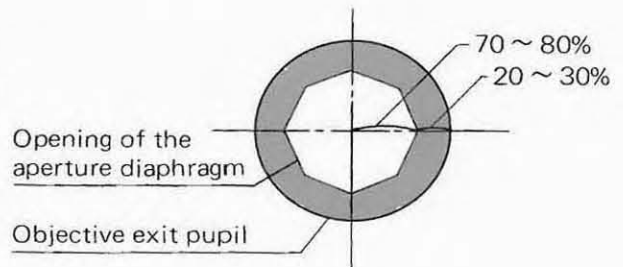

Fig. 16

E. Focus Adjustment

1. Tension of Coarse Adjustment Knobs and Fine Adjustment.

Although the tension of the coarse adjustment knobs has been already adjusted for optimum performance by the manufacturer, it is possible to personally adjust the tension of the coarse adjustment for either heavy or light movement depending on the operator's preference by rotating the tension adjustment ring ①. (Fig. 18)

The ring can be rotated by inserting a screwdriver into one of the holes on the periphery of the ring. The clockwise rotation (in the direction of the ARROW) tightens the coarse adjustment knobs. Do not loosen the ring too much, because the stage may drop or the fine adjustment knobs may slip.

NOTE: Do not rotate the right and left coarse adjustment knobs in the opposite directions simultaneously. If the stage drops and the specimen goes out of focus, the tension adjustment ring is too loose. Tighten the ring.

Use of Rubber Cap for Fine Adjustment Knob

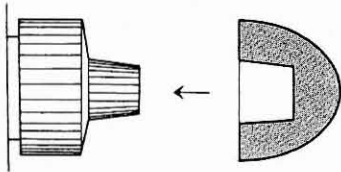

Attaching this cap over the fine adjustment knob increases the sensitivity of the fine focusing motion. (The rubber cap is optionally available.)

2. Pre-Focusing Lever

This lever ② is provided to prevent possible contact between specimen and objective as well as to simplify coarse focusing. (Fig. 19) The lever is locked after coarse focus has been accomplished. This prevents further upward travel of the stage by means of the coarse adjustment knobs, and automatically provides a limiting stop if the stage is lowered and then raised again. The pre-focusing lever does not restrict fine focusing.

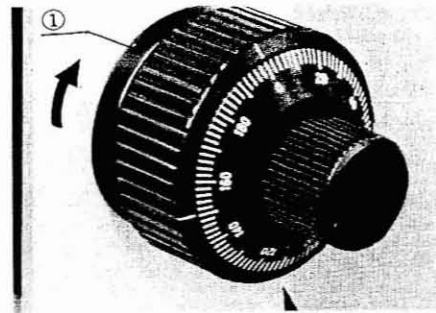

Fig. 18

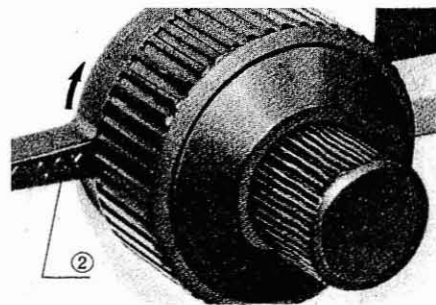

Fig. 19

F. Use of Immersion Objectives

- 1) Focus the specimen with a low power objective.
- 2) Put a drop of immersion oil on the specimen slide and the front lens of the immersion objective.
- 3) Rotate the revolving nosepiece to bring the immersion objective into the light path, and focus with the fine adjustment knobs.

NOTE: ① For immersion condensers such as an achromatic-aplanatic condenser or Abbe condenser, remove the specimen from the mechanical stage and place a drop of immersion oil on the front lens of the condenser. Then, place the specimen on the stage and slowly raise the condenser until firm contact with the underside of the specimen slide is made.

② Care should be taken to prevent oil bubbles from forming in the oil film between condenser and specimen slide. If any bubbles appear, re-apply immersion oil, for these bubbles greatly deteriorate the lens performance.

③ After use carefully wipe off the immersion oil deposited on the lens surfaces with gauze moistened with xylene. Never leave oil on the lens surfaces after use as oil remnants will seriously impair the performance of the lens system.

G. Photomicrography

The Olympus Photomicrographic Equipment Model PM-10AD is uniquely qualified to be used with the BHTU microscope for routine and advanced photomicrography. A separate, detailed instruction manual is available for the PM-10AD camera system.

For quick reference, however, you may want to refer to the following pointers when using the PM-10AD.

1. Photographic Eyepiece

Use NFK photo eyepieces for photomicrography.

Insert the eyepiece ① into the eyepiece tube of the photo tube. (Fig. 20)



Fig. 20

2. Mounting the Photographic Unit

Slip the body of the photographic unit over the photo tube. Align the dots on photo tube and the PM-10AD body and clamp the camera unit to the photo tube. (Fig. 21)

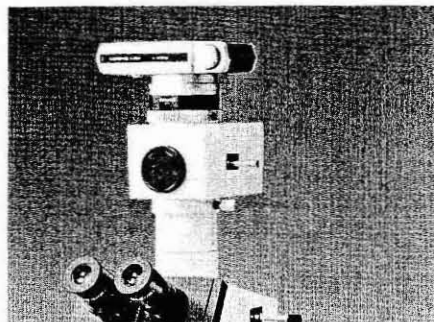

Fig. 21

3. Setting the Light Path Selector

Refer to section C.3. on page 12.

4. Focusing Procedure

Use the field of view eyepieces for focusing on the film plane. Each field of view eyepiece has a focusing front lens and a reticle with 4 frames, each frame indicating the area covered by a specific power NFK photo eyepiece. (Fig. 22) .

The number at each frame indicates the magnification of the photo eyepiece. The image in the field of view eyepiece and the image on the film plane are in focus at the same time. Several type field of view eyepieces are available, according to the film size employed.

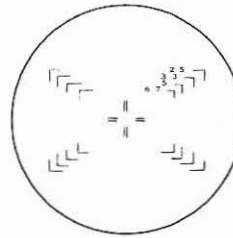

Fig. 22

Field of view eyepiece	35WHK10X	PWHK10X	4X5WHK10X	MHWHK10X
Attachment camera	35mm Back	3¼" x 4¼" Polaroid Back	4" x 5" Sheet Film or Polaroid Film Holder	16 mm Bolex camera 120 Roll Film Holder

- 1) Select the field of view eyepiece matching the camera back in use and insert it into the right eyepiece tube of the trinocular tube, aligning locating groove and locating pin.
- 2) While looking through the field of view eyepiece, rotate the eyepiece front lens in screw mount to focus on the double cross lines in the field. For sharp focusing with objectives 4X or lower, the focusing magnifier FT is recommended on account of their considerable depth of focus.
- 3) Bring the specimen detail to be photographed within the frame corresponding to the power of the NFK eyepiece in use and focus on the specimen with the microscope fine adjustment knobs. Make sure the light path selector knob on the observation tube is either on the white (V) or yellow-green (CV) band.
- 4) It is recommended to tighten the tension adjustment ring considerably to prevent the stage from dropping during long exposures.

VI. OPTICAL DATA

Objective	Type	D Achromat				D Plan Ach.			
		Magnification	4X	10X	40X	100X*	4X	10X	40X
	N.A.	0.10	0.25	0.65	1.30	0.10	0.25	0.65	1.25
	W.D. (mm)	18.2	7.2	0.6	0.20	7.03	7.4	0.27	0.17
	Focal length (mm)	30.03	16.9	4.58	1.91	34.23	17.5	4.67	1.75
Eyepiece	Resolving power (μ)	3.36	1.34	0.52	0.26	3.36	1.34	0.52	0.27
WK10X (Field number 20)	Total mag.	40X	100X	400X	1000X	40X	100X	400X	1000X
	Focal depth (μ)	171.6	27.45	3.0	0.7	171.6	27.45	3.0	0.7
	Field of view (mm)	5	2	0.5	0.2	5	2	0.5	0.2

*Immersion objectives

The resolving power and focal depth are obtained with fully opened aperture diaphragm.

Technical terms:

- Working distance: The distance from the cover glass to the nearest point of the objective.
- Numerical aperture: The N.A. represents a performance number which can be compared to the relative aperture (f-number) of a camera lens. The N.A. values can be used for directly comparing the resolving powers of all types of objectives. The larger the N.A., the higher resolving power.
- Resolving power: The ability of a lens to register small details. The resolving power of a lens is measured by its ability to separate two points.
- Focal depth: The distance between the upper and lower limits of sharpness in the image formed by an optical system. As you stop down the aperture iris diaphragm, the focal depth becomes larger. The larger the N.A. of an objective the shallower the focal depth.
- Field number: A number that represents the diameter in mm of the image of the field diaphragm that is formed by the lens in front of it.
- Field of view diameter: The actual size of the field of view in mm on the object surface.

VII. TROUBLESHOOTING GUIDE

If you are unable to obtain full performance from your microscope, please consult with the table below as pointers for troubleshooting.

Phenomenon	Cause	Remedy
1. Optical System		
a) With illuminator switched on, the field of view is dark.	Field iris diaphragm is not opened sufficiently.	Open diaphragm to proper diameter.
	Condenser is lowered too much.	Adjust condenser height.
	Light path selector lever is pulled out to C position.	Push in lever up to CV or V position.
b) Field of view is cut off or illuminated irregularly.	Light path selector lever is stopped midway.	Click it into proper position according to your purpose.
	Nosepiece is not clicked into place.	Slightly rotate nosepiece until it clicks into place.
	The power of objective used exceeds the illumination capacity of condenser.	Choose a condenser to meet your purpose.
	Condenser is not centered.	Center condenser.
	Field iris diaphragm is stopped down excessively.	Open diaphragm to proper diameter.
c) Dust or dirt is visible in the field of view.	Dust, etc. on light exit lens	Remove dust, etc. Clean front lenses.
	Dust on condenser top lens	
	Dirty specimen	
	Dust on eyepiece	
d) Excessive image contrast	Condenser is lowered too much.	Adjust condenser height.
	Aperture iris diaphragm is stopped down excessively.	Open diaphragm to proper diameter.

Phenomenon	Cause	Remedy
e) Resolution problems: <ul style="list-style-type: none"> • Image is not sharp. • Insufficient contrast. • Image details lack definition. 	LB objectives other than series are used.	Use Olympus LB series objectives.
	Objective is not correctly positioned in the light path.	Click nosepiece into place.
	Objective correction collar is not adjusted correctly.	Rotate correction collar, keeping specimen in fine focus until optimum resolution is obtained.
	Dust on objective front lens	Clean front lens.
	Immersion objective is not used with immersion oil.	Use immersion oil.
	Bubbles in immersion oil	Remove bubbles (and reapply oil).
	Immersion oil designated by Olympus is not used.	Use Olympus immersion oil.
	Dirty specimens Dust on condenser lens	Clean.
f) Field of view is partially out of focus, or image is partly out of focus.	Objective is not correctly positioned in the light path.	Slightly rotate nosepiece until it clicks in place.
	Specimen is not correctly positioned on stage.	Place specimen slide correctly on stage, and place stage clips open it.
g) Specimen image is partially out of focus.	Objective is not correctly positioned in the light path.	Slightly rotate nosepiece until it clicks into place.
	Condenser is not centered.	Center condenser.
h) Field of view becomes only slightly brighter by increasing voltage.	Condenser is not correctly centered.	Center condenser.
	Condenser is lowered too much.	Adjust condenser height.
2. Electric System		
a) Illuminator is too bright (or too dark) even when adjusting control lever.	Line voltage selector switch is not matched with local mains voltage.	Match selector switch to mains voltage.
c) Lamp goes off and on.	Bulb filament is likely to burn out.	Replace bulb.
	Loose electric connections.	Check all connections.
d) Bulb burns out frequently.	Line voltage selector switch is not matched with local mains voltage.	Match selector switch to mains voltage.
	Bulb is not standard one.	Use standard bulb.

Phenomenon	Cause	Remedy
3. Coarse and Fine Adjustments		
a) Coarse adjustment knob is too tight.	Tension adjustment ring is tightened too much.	Loosen ring properly.
	Users is trying to raise stage above the focusing limit with pre-focusing lever engaged.	Unlock pre-focusing lever.
b) Stage drops or specimen goes out of focus during observation due to slipping fine adjustment knobs.	Tension adjustment ring is too loose.	Tighten ring properly.
c) Stage cannot be raised to the upper limit.	Pre-focusing lever is engaged in lower than focusing position.	Unlock lever.
d) Stage cannot be lowered to the lower limit.	Condenser mount is lowered too much.	Raise condenser.
e) Objective front lens hits specimen before coming into focus.	Specimen is placed on stage upside down.	Reverse specimen.
4. Observation Tubes		
a) Incomplete binocular vision.	Interpupillary distance is not correctly adjusted.	Correct the interpupillary distance.
	Diopter adjustment is incomplete.	Complete the diopter adjustment.
	Right and left eyepieces are not matched.	Use a pair of matched eyepieces.
	User is unaccustomed to binocular vision.	Prior to looking into the binocular observation tube, look at a far away object.
5. Stage		
a) Image easily goes out of focus when you touch the stage.	Stage is not correctly locked.	Clamp stage securely.
b) Specimen stops midway on the east-west traverse.	Specimen is not correctly positioned.	Adjust specimen position.



OLYMPUS

OLYMPUS OPTICAL CO., LTD.

43-2, Hatagaya 2-chome, Shibuya-ku, Tokyo, Japan

OLYMPUS OPTICAL CO., (EUROPA) GMBH.

Wendenstrasse 14-16, Postfach 104908, 2000 Hamburg 1, Germany

OLYMPUS CORPORATION

4 Nevada Drive, Lake Success, N.Y. 11042-1179, U.S.A.

OLYMPUS OPTICAL CO. (U.K.) LTD.

2-8 Honduras Street, London EC1Y0TX, United Kingdom

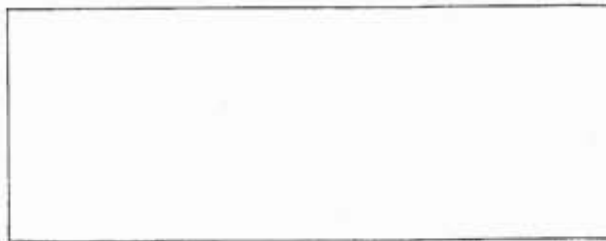

The design of the product is under constant review and whilst every effort is made to keep this manual up to date, the right is reserved to change specifications and equipment at any time without prior notice.

This publication is printed on recycled paper.

Printed in Japan 9303 M 10