

INSTRUCTIONS

SZ3060 **SZ4045/SZ4060** **SZ6045/SZ1145**

ZOOM STEREO MICROSCOPE

WARNING

This instruction manual has been prepared for use of the Zoom Stereo Microscope Model SZ3060/4045/4060/6045/1145. We recommend reading this manual carefully in order to familiarize yourself with its use so that you may obtain optimum performance from your model.

OLYMPUS®



BEFORE USE

1 Operation

- (1) As the microscope is a piece of precision equipment, always handle with care, avoiding abrupt movement or impact during transportation or operation of controls.
- (2) Avoid exposure to direct sunlight, high temperature and humidity, dust and vibration.
- (3) Avoid leaving dirt or fingerprints on the lens surfaces, as a dirty mirror or lenses may reduce image clarity.
- (4) Never turn the right and left zoom control knobs in opposite directions, as malfunction may result.

2 Care and Storage

- (1) Clean all glass components by wiping gently with gauze. To remove fingerprints or oil smudges, wipe with gauze slightly moistened with a mixture of ether (70%) and alcohol (30%).
⚠ Since solvents such as ether and alcohol are highly flammable, they must be handled carefully. Be sure to keep these chemicals away from open flames or potential sources of electrical sparks — for example, electrical equipment that is being switched on or off. Also remember to always use these chemicals only in a well-ventilated room.
- (2) Do not use organic solutions to wipe the surfaces of other components. Plastic parts especially, should be cleaned with a neutral detergent.
- (3) Never attempt to disassemble the microscope as decreased performance may result.
- (4) When not in use, be sure to cover the microscope with the dust cover provided, and store in an area free from moisture to prevent rust.

CONTENTS

1	STANDARD CONFIGURATIONS	1
2	SPECIFICATIONS	1
3	NOMENCLATURE	2
4	ASSEMBLY	2
5	OPERATION	3
1	Use of Stage Plates	3
2	Tension Adjustment of Focusing Knobs	3
3	Placement of a specimen	3
4	Diopter Adjustment and Focusing	3
5	Interpupillary Distance Adjustment	4
6	Use of Eyepiece Shields	4
7	Mounting and Removing Optional Eyepiece Micrometer	4
8	Use of Optional Conversion Lens	4
6	OPTICAL DATA	5
7	OPTIONAL ACCESSORIES	7
8	TROUBLESHOOTING GUIDE	8

1 STANDARD CONFIGURATIONS

Component	Model	Quantity	SZ3060	SZ4045	SZ4060	SZ6045	SZ1145
Microscope body	SZ3060-F	1	○				
	SZ4045-F	1		○			
	SZ4060-F	1			○		
	SZ6045-F	1				○	
	SZ1145-F	1					○
Eyepiece	GSWH10X	2	○	○	○	○	○
Stand	SZ-ST	1	○	○	○	○	○
Stage plate	SP-BW-2	1	○	○	○	○	○
Stage clip		2	○	○	○	○	○
Dust cover		1	○	○	○	○	○

Note: ○ indicates the compatible components for each model.

2 SPECIFICATIONS

Description	Model	SZ3060	SZ4045	SZ4060	SZ6045	SZ1145
Microscope body	Magnification	0.9–4×	0.67–4×		1–6.3×	1.8–11×
	Zoom ratio	4.4	6		6.3	6.1
	Working distance	110 mm			100 mm	73 mm
	Observation tube inclination	60°	45°	60°	45°	45°
	Interpupillary distance adjustment	Right and left tubes interlocked Adjustment range: 50–76 mm (with GSWH10X)				
	Diopter adjustment	Provided on one eyepiece tube only			Provided on both eyepiece tubes	
		Diopter adjustment range: ± 5 m ⁻¹ (per meter)				
	Zoom driver	Horizontal axial drive control knobs				
Conversion lens mount	Screw-in (M48X0.75)					
Eyepiece	GSWH10×	Field number (F.N.) 22, φ24 mm micrometer mountable				
Stand	Microscope body mount	Fit into mounting port with inner diameter of 76 mm				
	Focusing	Rack-and-pinion drive on ball bearing guides, knob rotation tension adjustment, focusing range: 120 mm				
	Stage plate	φ100 mm, frosted white on one side and black on the other side				
	Stage clip	Pressed down from above				
	Illuminator mount	Epi-illuminator (LSGA) and trans-illuminator base mountable				

3 NOMENCLATURE

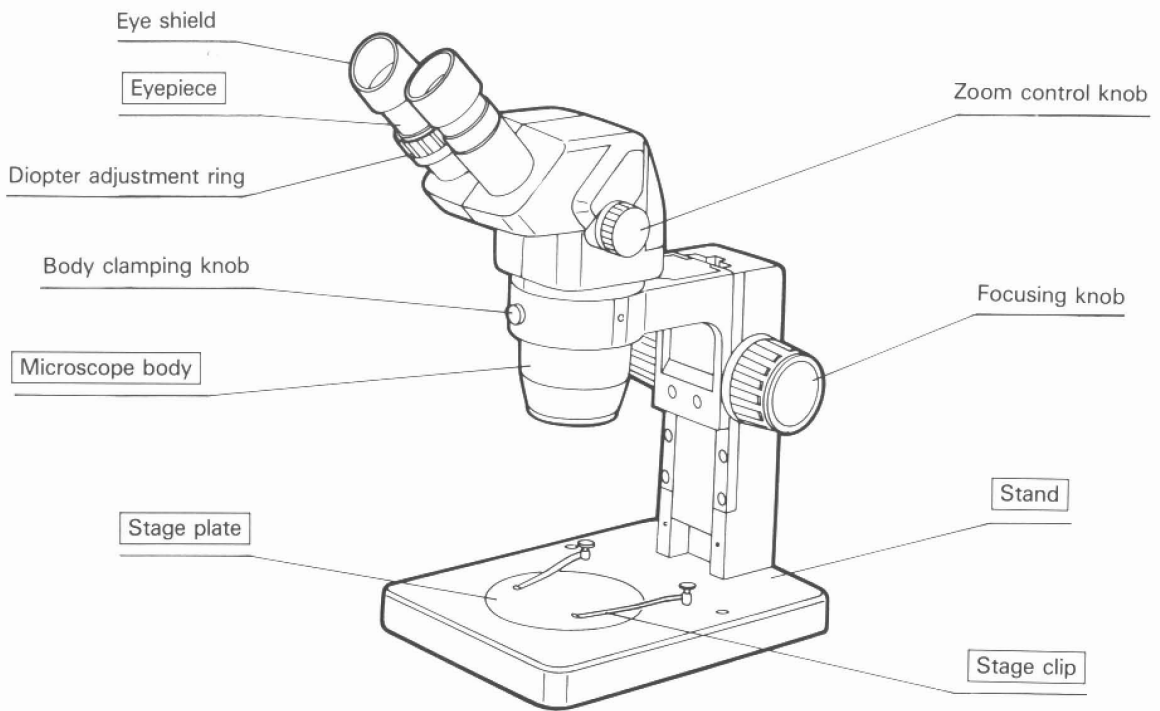

4 ASSEMBLY

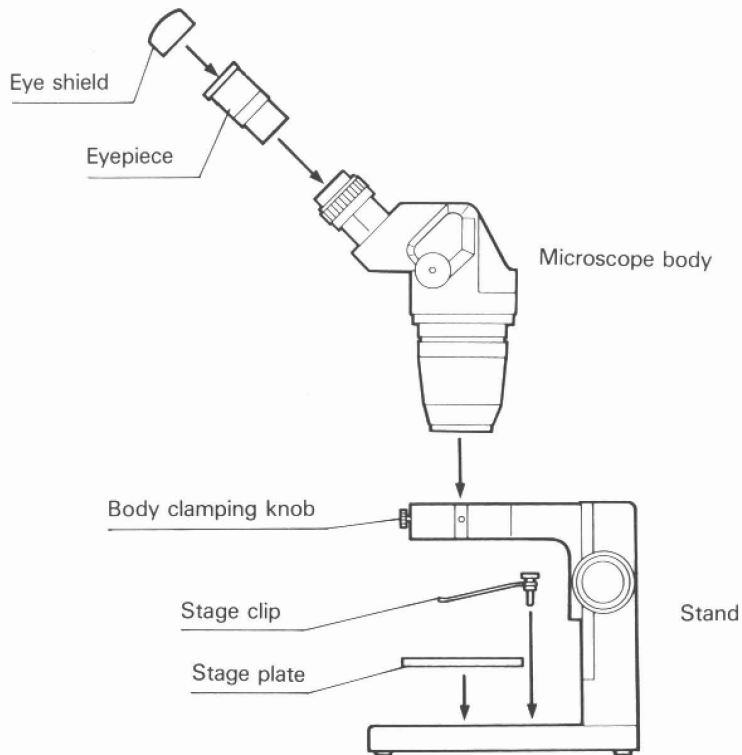

5 OPERATION

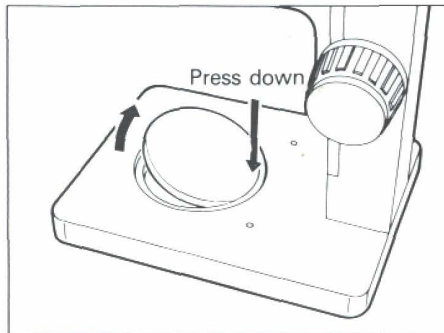

Fig. 1

1 Use of Stage Plates

- (1) Usually, the stage plates are used with the frosted white side facing the objective. However, if the specimen is white or brightly colored, use the black side of the plate as the darkened background increases image contrast.
- (2) To remove the stage plates, press down the supporting end of the plate with a fingertip, and the other end will flip up. (Fig. 1)

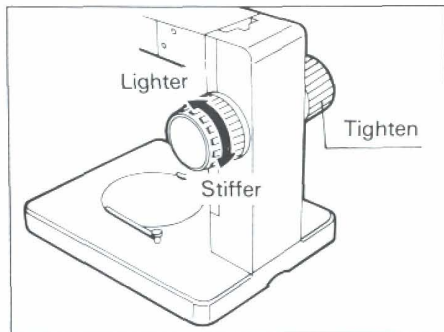

Fig. 2

2 Tension Adjustment of Focusing Knobs

- (1) Turn one focusing knob with the other focusing knob tightened, by holding both knobs, in order to increase or decrease the rotation tension, depending on the turning direction. (Fig. 2)
- (2) This adjustment is intended to prevent the microscope body from drifting. Set the knob tension at a level slightly stiffer than that to ensure no unintentional movement and facilitate easy operation.

3 Placement of a specimen

- (1) Place the specimen in the center of the stage plate, and hold the specimen with the stage clips if necessary.
- (2) Illuminate the specimen using an optional illuminator.

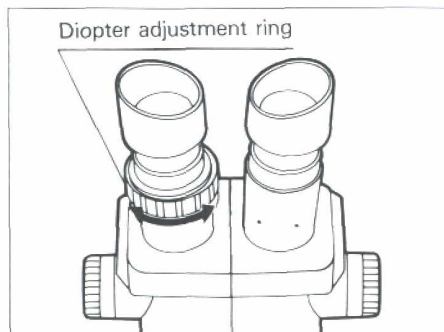

Fig. 3

4 Diopter Adjustment and Focusing

For SZ3060, SZ4045 and SZ4060

- (1) Minimize the magnification power by turning the zoom control knobs.
- (2) Looking through the right eyepiece, bring the specimen into focus by turning the focusing knobs.
- (3) Looking through the left eyepiece, bring the specimen into focus by turning the diopter adjustment ring. (Fig. 3)
- (4) Maximize the magnification power by turning the zoom control knobs, and bring the specimen into focus by turning the focusing knobs.

For SZ6045 and SZ1145

- (1) Maximize the magnification power by turning the zoom control knobs.
- (2) Looking through the right eyepiece, bring the specimen into focus by turning the focusing knobs.
- (3) Minimize the magnification power by turning the zoom control knobs.
- (4) If the specimen goes out of focus, readjust the focus by turning the right diopter adjustment ring only. (Fig. 4)
- (5) Maximize the magnification power again by turning the zoom control knobs. If the specimen goes out of focus, repeat steps (2) through (4) above. This allows more precise diopter adjustment.
- (6) Minimize the magnification power by turning the zoom control knobs and, looking through the left eyepiece, bring the specimen into focus by turning the left diopter adjustment ring only. (Fig. 4)

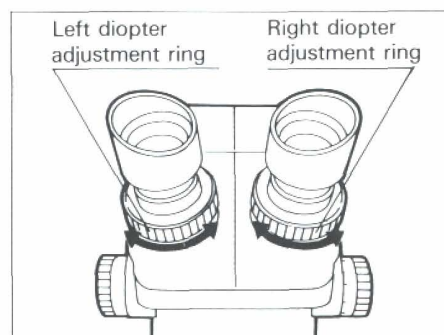

Fig. 4

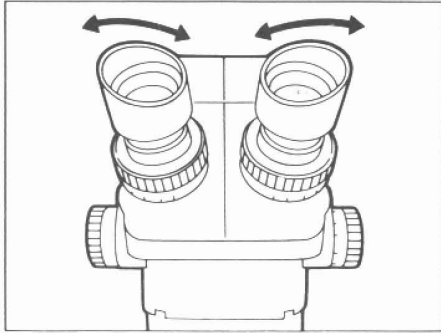

Fig. 5

5 Interpupillary Distance Adjustment

Holding the right and left eyepiece tubes, push or pull the tubes in the direction of the ARROWS until perfect binocular vision is obtained. (Fig. 5)

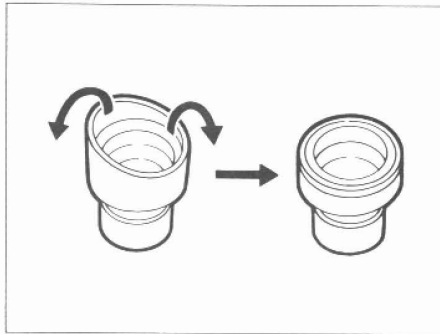

Fig. 6

6 Use of Eyepiece Shields

For those who do not wear eyeglasses

Hold the diopter adjustment rings so that they can not rotate, and align the direction of the eyepiece shields to the observer's face by turning the eyepieces. In this way, the observer can keep his eyes closer to the eyepiece shields during observation.

For those who wear eyeglasses

Fold back the eyepiece shields with both hands as shown in Fig. 6.

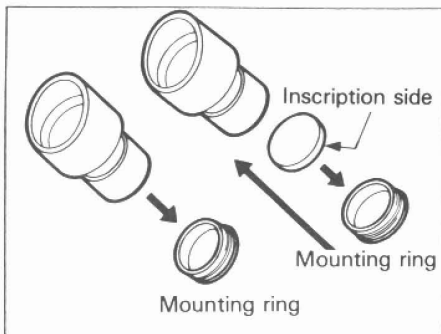

Fig. 7

7 Mounting and Removing the Optional Eyepiece Micrometer

- (1) Twist out and remove the mounting rings from the eyepieces. (Fig. 7)
- (2) Remove dirt or dust from the eyepiece micrometer, and mount it to the mounting ring with the inscription side facing downward. (Fig. 7)
- (3) Gently screw the mounting ring containing the eyepiece micrometer into the eyepiece and tighten securely. (Fig. 7)
- (4) To remove the eyepiece micrometer, twist the mounting ring. Wrap the micrometer in clean, soft paper for storage.

★ The $\varnothing 24$ -mm eyepiece micrometer can also be mounted on the GSWH15X. However, since the eyepiece's field number is 16, the micrometer graduations and grids beyond 16 mm are not visible.

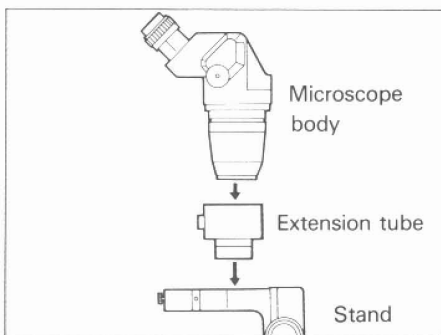

Fig. 8

8 Use of Optional Conversion Lens

- (1) Screw the conversion lens into the mounting thread at the bottom of the microscope body.
- (2) As the working distance of the 0.5X conversion lens (110AL0.5X and 100AL0.5X) is long, use the extension tube (SZ-ET) when making observations using the stand. (Fig. 8)

★ 73AL0.5X doesn't require extension tube.

★ 0.25X, 0.3X, and 0.4X conversion lenses cannot be used with the stand due to their long working distances.

★ Please note that three types of conversion lenses are available — one for the SZ3060, SZ4045 and the SZ4060 and one for the SZ1145, and the other for the SZ6045.

6 OPTICAL DATA

The following data indicates typical zoom magnification factors.

1. SZ3060, 4045 and 4060

Zoom magnification	W.D. (mm)	Eyepiece		Eyepiece (option)					
		GSWH10X F.N.22		GSWH15X F.N.16		GSWH20X F.N.12.5		GSWH30X F.N.7	
		Total magnification	Field of view (mm)	Total magnification	Field of view (mm)	Total magnification	Field of view (mm)	Total magnification	Field of view (mm)
0.67x	110	6.7x	32.8	10x	23.9	13.4x	18.7	20x	10.4
0.9x		9x	24.4	13.5x	17.8	18x	13.9	27x	7.8
1x		10x	22	15x	16	20x	12.5	30x	7
2x		20x	11	30x	8	40x	6.3	60x	3.5
4x		40x	5.5	60x	4	80x	3.1	120x	1.8

Conversion Lens for SZ3060, 4045, 4060 (Option)

Conversion lens	W.D. (mm)	Conversion lens	W.D. (mm)
110AL 0.25x	400	110AL 0.62x	160
110ALK 0.3x	350-250	110AL 0.75x	130
110ALK 0.4x	250-180	110AL 1.5x	61
110AL 0.5x	200	110AL 2x	38

★ The working distances of the 110ALK0.3X and 0.4X may vary depending on the microscope. The indicated values (0.3X and 0.4X) show the magnification power at a working distance of 350 mm and 250 mm.

★ The 110AL 2X Conversion lens cannot be used with the Fiber Optics Ring Light (LGR-2).

2. SZ6045

Zoom magnification	W.D. (mm)	Eyepiece		Eyepiece (option)					
		GSWH10X F.N.22		GSWH15X F.N.16		GSWH20X F.N.12.5		GSWH30X F.N.7	
		Total magnification	Field of view (mm)	Total magnification	Field of view (mm)	Total magnification	Field of view (mm)	Total magnification	Field of view (mm)
1x	100	10x	22	15x	16	20x	12.5	30x	7
2x		20x	11	30x	8	40x	6.3	60x	3.5
4x		40x	5.5	60x	4	80x	3.1	120x	1.8
6.3x		63x	3.5	95x	2.5	126x	2	189x	1.1

Conversion Lens for SZ6045 (Option)

Conversion lens	W.D. (mm)
100AL 0.5x	186
100AL 1.5x	56
100AL 2x	36

★ The 110AL 2X Conversion lens cannot be used with the Fiber Optics Ring Light (LGR-2).

- The working distance is fixed, regardless of the magnification factor.

Total mag. = Zoom mag. × Eyepiece mag. × Conversion lens mag.*

Diameter of field of view (mm) = $\frac{\text{Field number of eyepiece}}{\text{Zoom mag.} \times \text{Conversion lens mag.*}}$

*Note: When a conversion lens is not being used, the conversion lens mag. should be set at 1.

3. SZ1145

Zoom magnification	W.D. (mm)	Eyepiece		Eyepiece (option)					
		GSWH10x F.N.22		GSWH15x F.N.16		GSWH20x F.N.12.5		GSWH30x F.N.7	
		Total magnification	Field of view (mm)	Total magnification	Field of view (mm)	Total magnification	Field of view (mm)	Total magnification	Field of view (mm)
1.8x	73	18x	12.2	27x	8.9	36x	6.9	54x	3.9
4x		40x	5.5	60x	4	80x	3.1	120x	1.8
8x		80x	2.8	120x	2	160x	1.6	240x	0.9
11x		110x	2	165x	1.5	220x	1.1	330x	0.6

Conversion Lens for SZ1145

Conversion lens	W.D. (mm)
73AL 0.5x	114
73AL 1.5x	36
73AL 2x	19

- ★ The 73AL 1.5X and 73AL 2X cannot be used with the Fiber Optics Ring Light (LGR-2).
- Working distance is fixed, regardless of the magnification factor.
- Total magnification and diameter of field of view can be calculated with the following formula.

$$\text{Total mag.} = \text{Zoom mag.} \times \text{Eyepiece mag.} \times \text{Conversion lens mag.}^*$$

$$\text{Diameter of field of view (mm)} = \frac{\text{Field number of eyepiece}}{\text{Zoom mag.} \times \text{Conversion lens mag.}^*}$$

*Note: When a conversion lens is not being used, the conversion lens mag. should be set at 1.

7 OPTIONAL ACCESSORIES

1. Epi-illuminator Model LSGA-3, LSGA-6

Employing a 6V 15W halogen bulb, this illuminator mounts directly onto the microscope stand (SZ-ST). A heat-insulating filter and frost glass are built-in.

2. Fluorescent ring illuminator Model SZ-FLR

This illuminator is mounted to the objective of the microscope, providing bright, even fluorescent illumination. A 10W ring fluorescent bulb is incorporated.

3. Trans-illuminator base Model SZ-ILA

Used in combination with the SZ-ST stand. Capable of polarizing illumination, the SZ-ILA also provides a choice of 6V 15W or 12V 50W halogen bulb.

4. Arms for equipment mounting

4 types of arms for equipment mounting are available depending on the application.

- (1) Prober arm Model SZ-STP
- (2) Bonder arm Model SZ-STB1 for B&L stereo microscopes
- (3) Bonder arm Model SZ-STB2 for Olympus stereo microscopes
- (4) Arm Model SZ-STS for SZH stereo microscope bases

5. Large size microscope stand Model SZ-STL

6. Universal stand Model SZ-STU1

7. Fiber optics ring light Model LGR-2

The illuminator has a 15V 150W halogen bulb to provide a bright, clear and shadow-free field of view.

8. Light guide with bifurcated fiber optics Model LGW

Capable of illuminating from any angle or position with the flexible arm, the LGW employs a 15V 150W bulb.

9. Stand illuminator Model LSD

This stand illuminator is used when intense lighting is required. Either parallel or convergent luminous flux can be selected.

10. Extension tube Model SZ-ET

When a 0.5X conversion lens (110AL0.5X or 100AL0.5X) is used, combine the extension tube with the stand.

11. Eyepiece micrometer

The eyepiece micrometer is mounted to the field iris diaphragm and used for length measurement within the field of view. 9 types of micrometer reticles are available as shown in Fig. 15.

Eyepiece micrometers

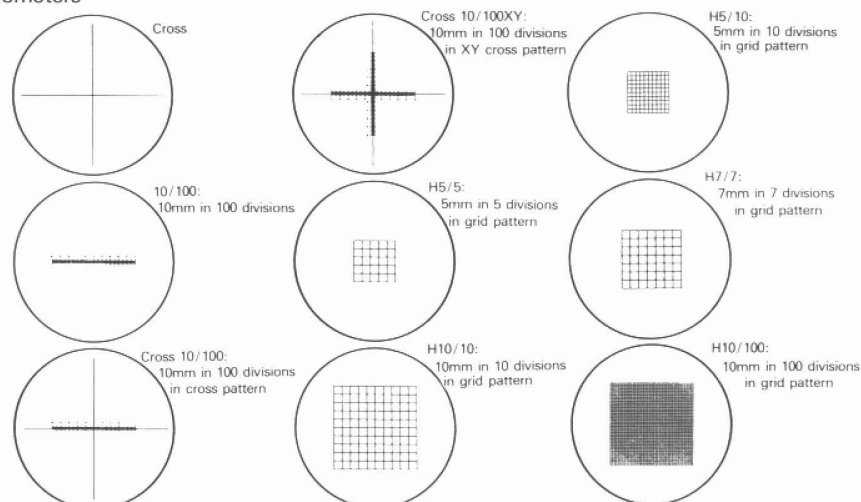

Fig. 15

8

TROUBLESHOOTING GUIDE

If 100% performance is not obtained from your microscope due to unfamiliarity with its use, the table below may provide some guidance.

Symptom	Cause	Remedy
1. Incomplete binocular vision	The interpupillary distance is not adjusted correctly.	Correct the interpupillary distance.
	Diopter adjustment is incomplete.	Complete diopter adjustment.
	The right and left eyepieces are different.	Replace and mount the same eyepieces.
2. Stains or dust are observed on the field of view.	Stains or dust have accumulated on the specimen.	Clean thoroughly.
	Stains or dust have accumulated on the eyepieces.	Clean thoroughly.
3. Unclear image	Stains or dust have accumulated on the objective.	Clean thoroughly.
4. Image blurs when zoomed.	Diopter adjustment of the eyepieces is incomplete.	Complete diopter adjustment.
	Focus adjustment is incomplete.	Complete focus adjustment.
5. The focusing knob is stiff.	The focusing knob tension adjustment is too tight.	Loosen appropriately.
6. Poor focus during observation due to unintentional lowering of the zoom microscope body.	The focusing knob tension is too loose.	Tighten appropriately.